

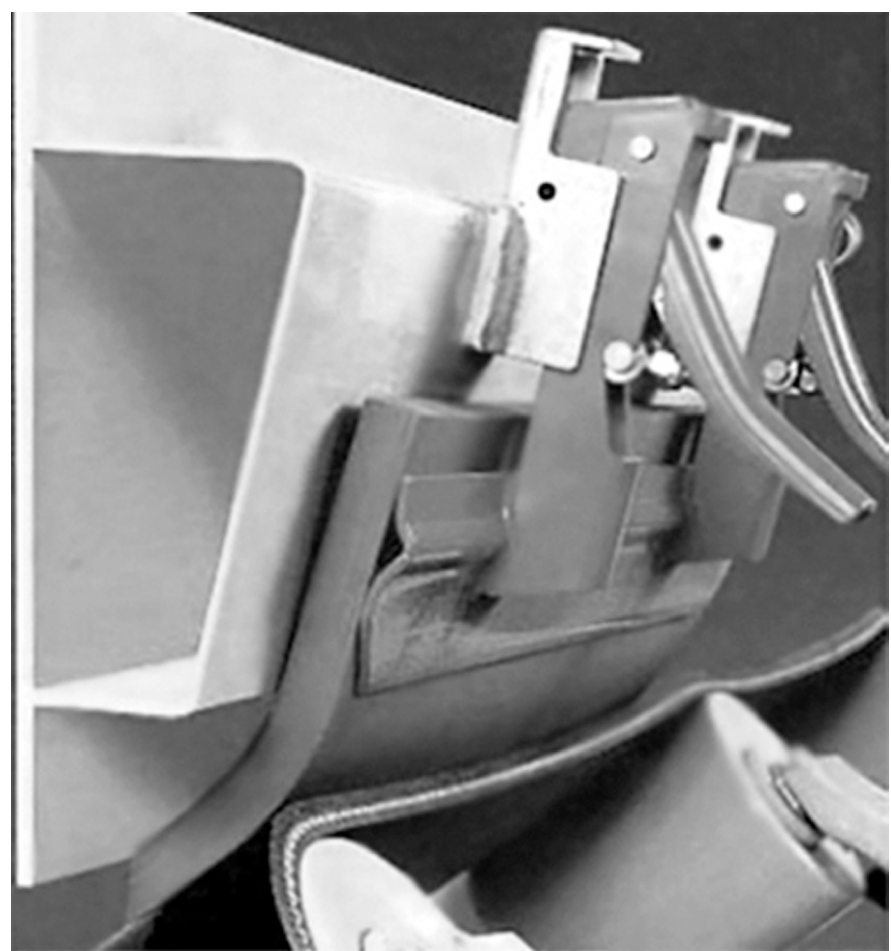

CLAMP MOUNT SKIRTING SYSTEM

CLAMP MOUNT / DURA-SEAL / TRACKKEEPER / VACU-SKIRT

INSTALLATION, OPERATION & MAINTENANCE INSTRUCTIONS



Check us out at www.asgco.com

Customer Service
800-344-4000



24 Hour Emergency Service and Parts
610-821-0210



ASGCO Mfg., Inc.
301 Gordon Street
Allentown, PA 18102
610-821-0216
FAX 610-778-8991

Important Safety Notice

Always observe the basic rules of safety when working with any conveyor system. To avoid injury and equipment damage, be sure that all controls to the conveyor are locked out and the power source is disconnected at all times during installation.

Installation Tools

In addition to the items provided by ASGCO, you will need some or all of the following, depending on the configuration of the system you will install.

1. Adjustable wrenches or open-end wrenches
2. Marking crayon or soapstone
3. Folding rule and/or tape measure
4. Cutting Torch
5. Carpenter's square
6. Welding equipment
7. Metal Saw
8. Level

Introduction

ASGCO Clamp Mount is a skirting system featuring two options, Clamp Mount I and Clamp Mount II. Clamp Mount I is a system where the actual clamps are on two (2) foot centers and is used where only moderate clamping forces are needed such as the skirt extensions beyond the load zones. Clamp Mount II is a system where the clamps are on one (1) foot centers and is used where maximum clamping forces are needed such as in the load zone where there is high impact on the belt and on the rear of the chute wall.

Clamp Mount can be installed in several different configurations. Look at the illustrations below and determine which configuration corresponds to the equipment that needs to be installed.

Standard Clamp Mount Skirt sealing mounted flush to the skirtboard. Sealing compound is generally vertical.

(See Page 4)

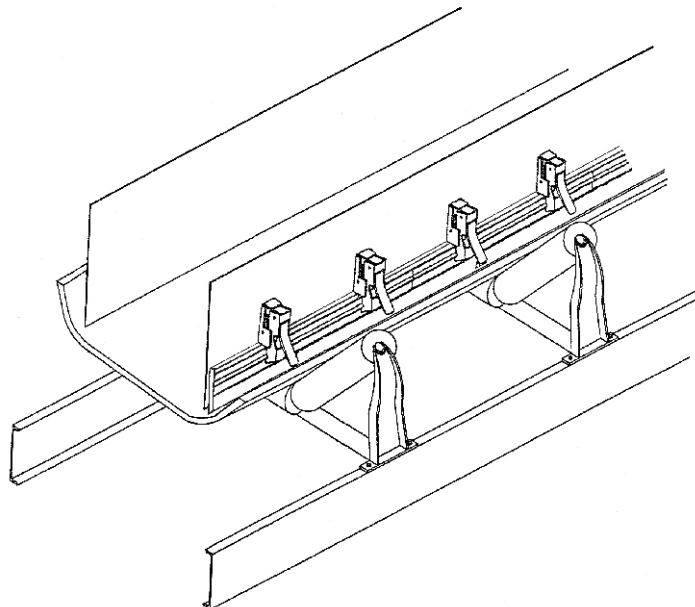

Clamp Mount with Support Plate
where the sealing compound is
flexed and laying on the belt.

(See Page 9)

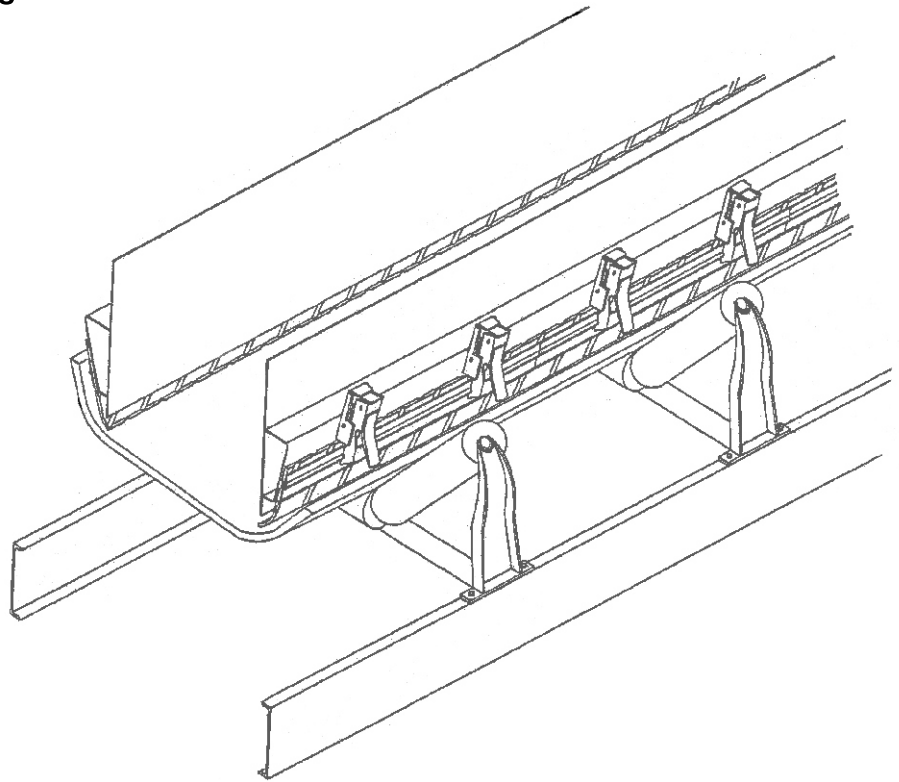

Clamp Mount is being adapted
to retrofit into a Martin Trac-
Mount System.

(See Page 12)

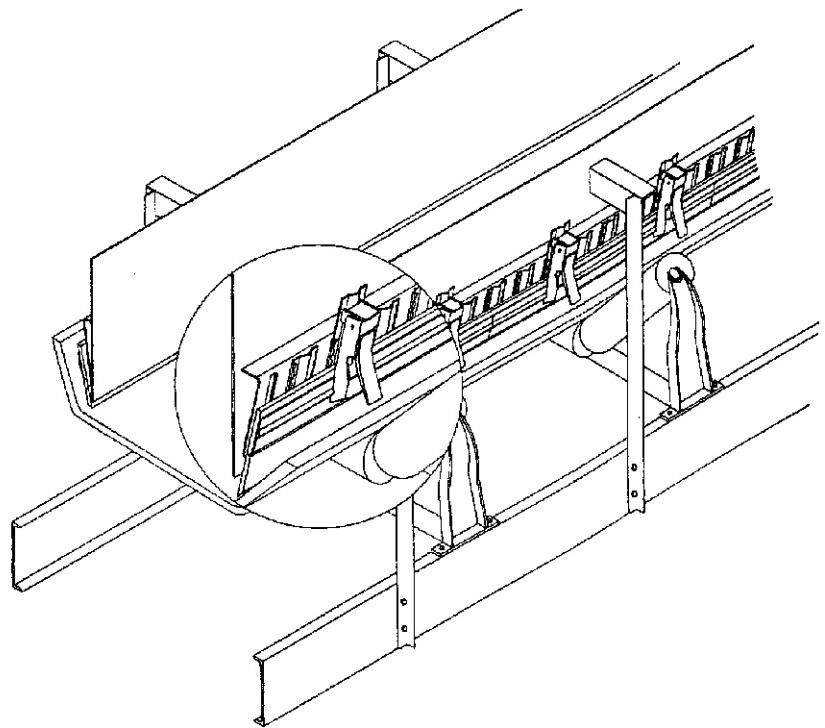

CLAMP MOUNT™ with DURA SEAL

Standard Clamp Mount Installation Instructions

1. Remove the existing sealing compound and mounting hardware. Make sure that the chute wall is clear of **all** old brackets, bolts, studs, etc.
2. Measure the gap between the bottom of the chute wall and the belt. ASGCO recommends that this distance be $\frac{1}{2}$ " at impact point increasing to $1\frac{1}{2}$ " over the length of the chute wall. This will allow material to roll forward and not get trapped or wedged in place. When the gap is greater than 3"; Additional chute wall must be added prior to installation of the Clamp Mount Skirting System.

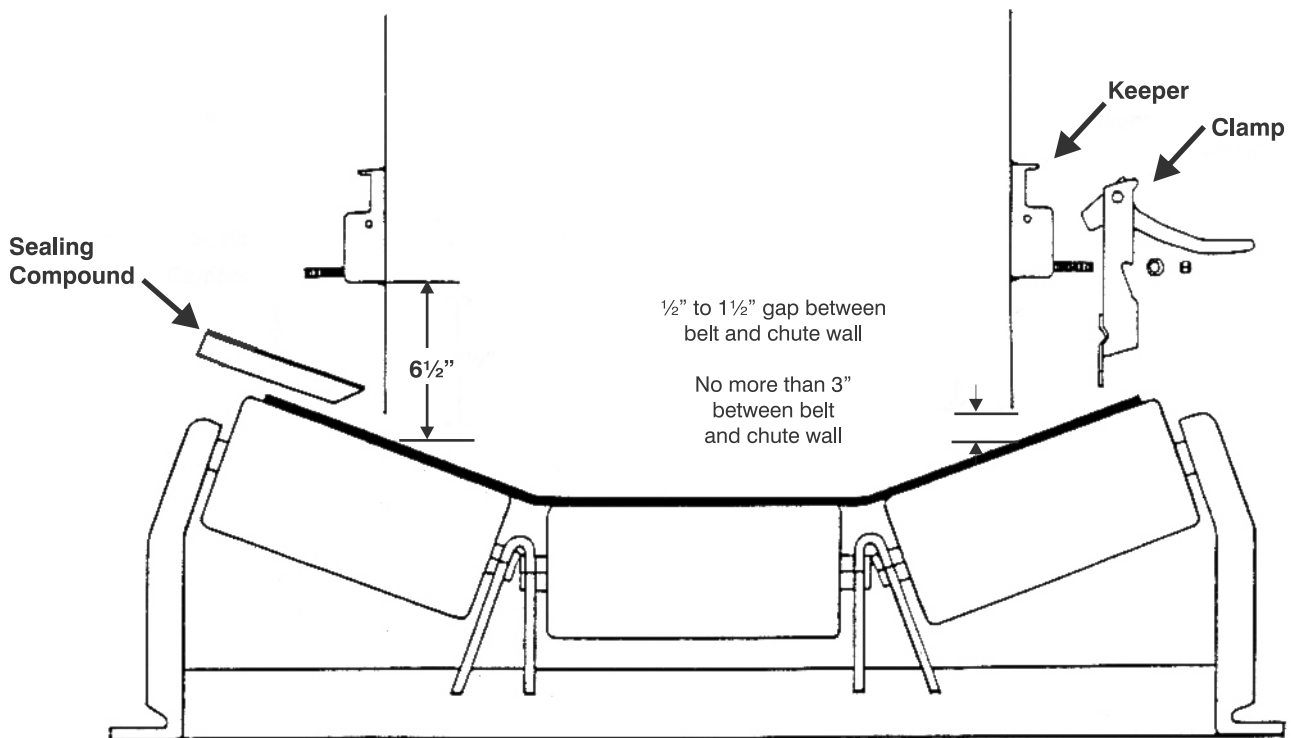

3. **Clean the chute wall at the approximate locations of the keepers,** To ensure a good weld and correct clamping force onto the sealing compound, there must be a clean flat surface for mounting the keepers.

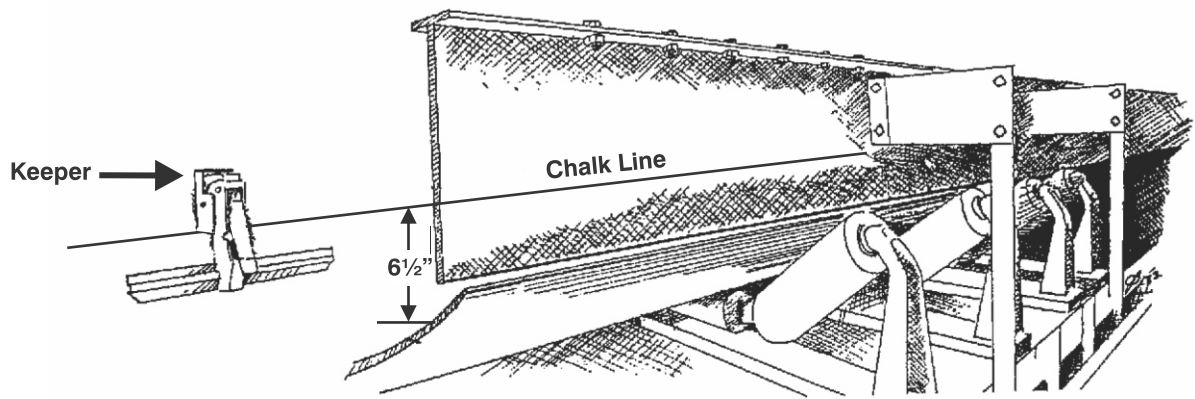

4. **When locating and installing Clamp Mounts, always work from the rear of the chute wall toward the head pulley.** On each straight run of the belt (that is, without any change in the angle of elevation of the belt), the first step is to determine the proper height for each keeper. Use a straight edge to measure **exactly 6 $\frac{1}{2}$ " up from the belt surface** onto the chute wall and mark that point Repeat this measuring and marking at several points in the straight run, including at the rear and head of the chute wall. These marks on the wall show the location of the **bottom of the keepers**.
5. Use a chalk line to connect the location marks. You need this line to make sure the clamp assemblies will be at the proper distance above the belt when you finish the installation work.

NOTE: At a change in the angle of elevation of the belt you must measure the 6 $\frac{1}{2}$ " position for the bottom of the keeper before and after the change in elevation angle.

Positioning of the Clamp Mount

6. When a combination of Clamp Mount I and II are used: Begin positioning the Clamp Mount II's along the belt. Note: Clamp Mount II is used at elevation changes, terminal points, the rear of the chute wall, and high vibration and impact areas. After the Clamp Mount II's, position the Clamp Mount I's along the belt between the Clamp Mount II's.
7. Now you need to lay out the spacing for the keepers Starting at the rear of the chute wall, hold the first Clamp Mount against the chute wall with the bottom of the keeper positioned on the chalk line you just made. Make chalk marks on the wall to outline the top and sides of the keeper, and both ends of the clamp- blade. Move toward the head pulley and hold the next Clamp Mount against the wall with a gap of 1/8" to 1/4" between the blade-ends of the first and second Clamp Mount Mark the outline of the second Clamp Mounts keeper and blade-ends Repeat this for the third Clamp Mount and so on until you reach the head end of the chute wall - or until there is a change in the angle of elevation of the belt

NOTE: Check the Position of the neighboring Clamp Mounts by measuring the distance between the center of adjacent blades - it should be about 24".

8. In the event of an obstruction on the chute wall, you have two options:

- a) The gap between the clamp-blades can be increased to as much as 2" to avoid the obstruction. (The Clamp can be temporarily inserted into the keeper to determine the increased distance.) Do not increase the gap beyond 2" or the system may not function properly.
- b) The involved clamp-blades may be shortened, either by sawing (preferably) or cutting with a torch. If torch is used, the area affected by the heat must be painted to prevent rusting. Whichever method is used, be sure to cut the same amount off each side of the clamp.

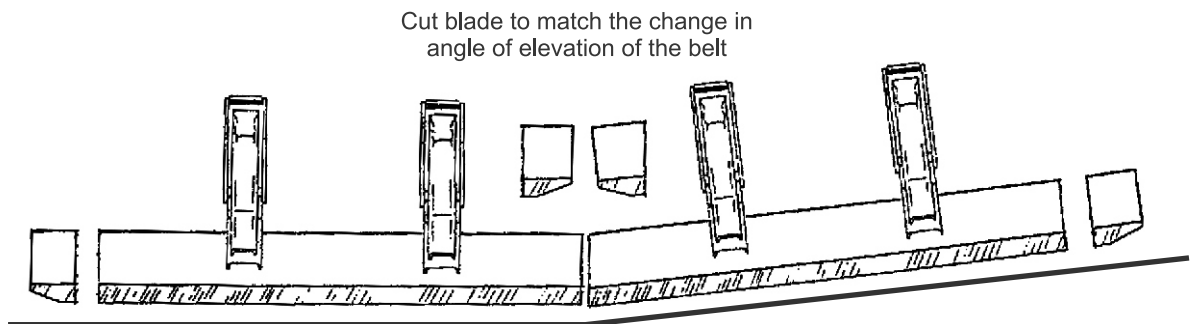

9. Remove the keeper from the clamp assembly. Fasten each keeper to the chute wall with a bead weld at the top and bottom of the keeper. Optional method: Instead of a top bead weld, make plug welds in the holes provided and a bead weld at the bottom. This prevents the keeper from bending during operating pressure.

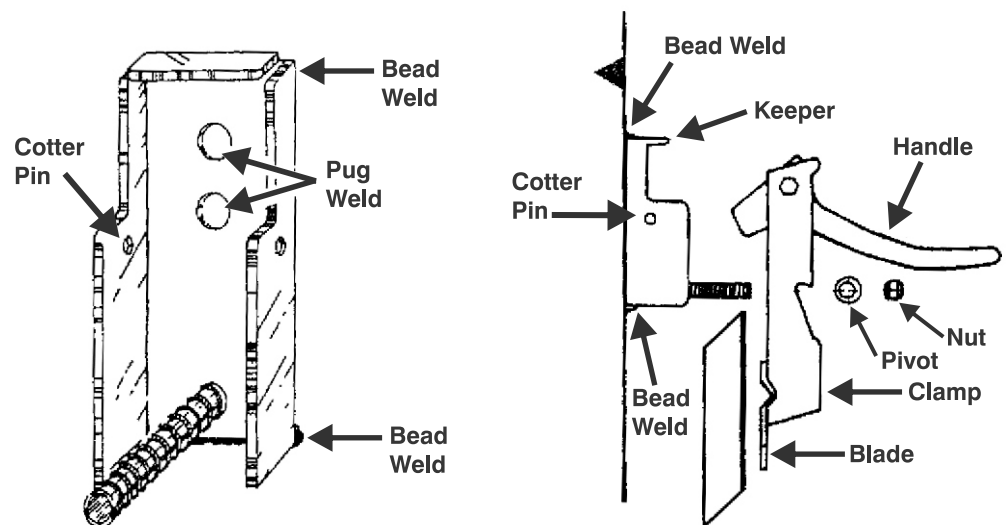

-
10. Install the clamp assembly on the keeper. Position the pivot parallel to the blade, with its protruding ends sitting firmly in the notched portion of the housing and tighten the adjusting nut to secure the clamp assembly. **Using only hand pressure, close the handle.**

Installation of Sealing Compound - Dura Seal

1. Lay the compound on the belt below the keepers. If the compound has a beveled edge, position the compound as shown in the first illustration. With a sharp knife, cut the sealing compound to the correct length, preferably in one piece.
2. If more than one length of sealing compound is required, follow this procedure for making buff joints: Cut the end of the first length at a 45° angle, then cut a mating 45° angle on the adjoining end of the second length. When using Clamp Mount I assemblies, the butt joint should be positioned as close to the keeper as possible. When using Clamp Mount II assemblies position the buff joint as close as possible to the center line between the keepers, Always make a butt joint as tight and as smooth as you can. And never locate a butt joint near the blade-ends, or at the small gap between blade-ends. This method for making butt joints can also be used when replacing sections of heavily worn sealing compound
3. Position the sealing compound on the chute wall. If there is a beveled edge, make sure the beveled edge is parallel to the belt angle, as shown in the previous illustration. Install the clamp assembly on the keeper. Position the pivot parallel to the blade, with its protruding ends sitting firmly in the notched portion of the housing and tighten the adjusting nut to secure the clamp assembly. **Using hand pressure only, close the handle.**
4. When all the clamp assemblies on one side of the chute wall have been installed, position the sealing compound so that it lightly touches the belt. Then tighten the adjusting nut with a wrench. If the handle cannot be opened and closed by hand the adjusting nut is too tight.
5. To adjust the sealing compound: Open one clamp at a time and lower or raise the compound until it touches the belt 'lightly, then close the handle. **Remember:** You must be able to open and close the handle with only hand pressure.
6. In areas of high vibration or impact: Install a cotter pin in the keeper after the sealing compound is in position. This will prevent accidental opening of the handle.

Sealing the Rear of the Chute Wall

1. Measure **exactly** 6½" up from the belt surface onto the **outside** of the chute wall and mark points above the right and left ends of the horizontal idler. Connect these points with a chalk line. This line shows the location of the **bottom** of the keepers.

- To determine the location of the keepers: Position the clamp assemblies with the bottom of the keeper along the chalk line. Mark the sides and top of the keepers and the blade ends.

When the blade is too long: Cut off an equal length from both blade ends

Rear View of Conveyor

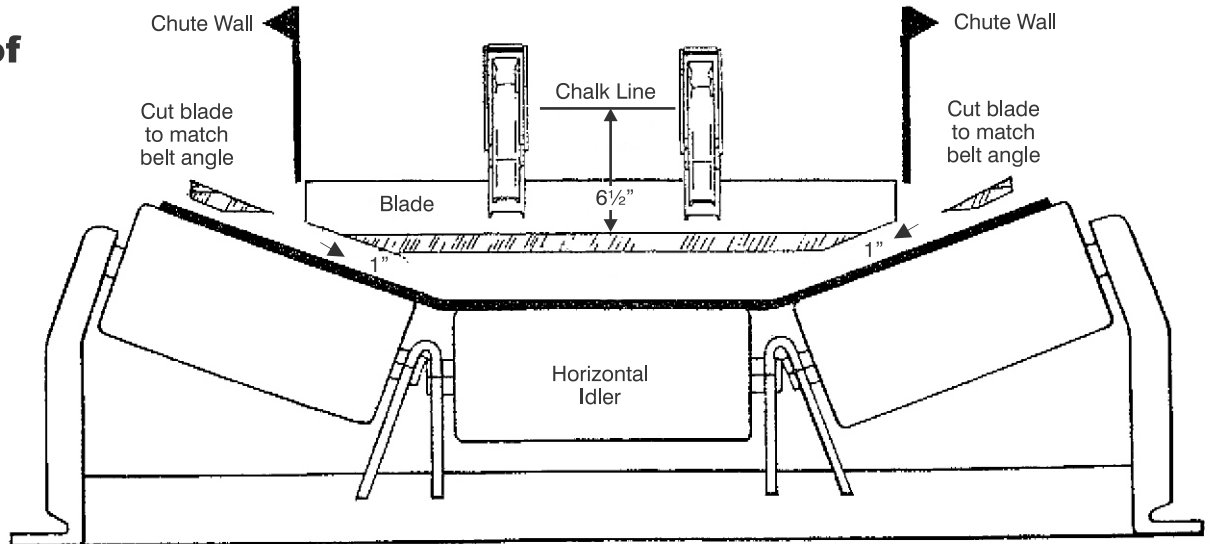

When the belt is angled up at its sides: The blade ends must be trimmed to match the angle of the belt.

IMPORTANT: A minimum 1" clearance is required between the clamp-blade and the belt at all points in this installation. If the blade touches the belt, it could damage the belt or foul the operation of the conveyor.

- Fasten each keeper to the chute wall with a bead weld at the top and bottom of the keeper.
- Install the clamp assembly on the keeper. Position the pivot parallel to the blade, with its protruding ends sitting firmly in the notched portion of the housing and tighten the adjusting nut to secure the clamp assembly. **Using only hand pressure**, close the handle.
- Trim and position the sealing compound so that it lightly touches the belt. Then tighten the adjusting nut with a wrench. If the handle cannot be opened and closed by hand, the adjusting nut is too tight.

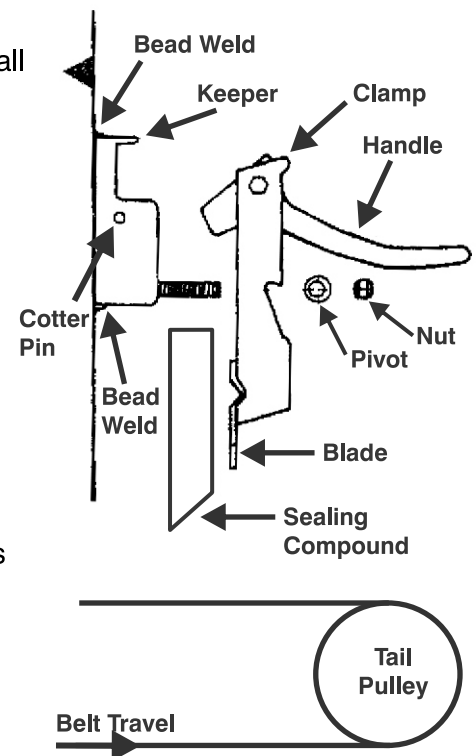

CLAMP MOUNT™ with SUPPORT PLATE

with DURA SEAL, TRI-SEAL, MULTI -SEAL, VACU-SKIRT

Clamp Mount with Support Plate Instructions

Parts List

Description	Part Number
Clamp Mount I	ASG-CK-1
Clamp Mount II	ASG-CK-2
Support Plate	ASG-CZ-10

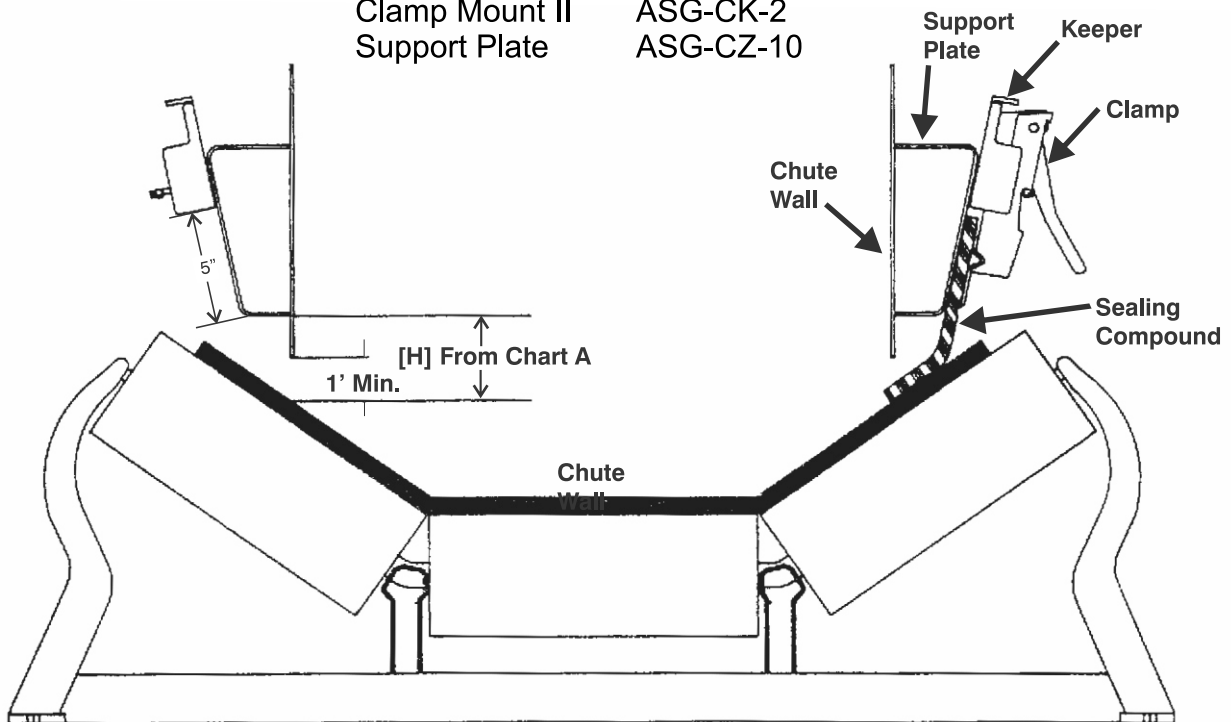

Installing Support Plates

Always begin at the tail [rear] end of the conveyor and work towards the head pulley.

Installation of sealing compound with support plate is done in the following steps:

- Check existing chute for clearances
- Remove old skirting
- Modify chute if required
- Mark chute for ClampMount support plates
- Install ClampMount
- Install sealing compound

CHART A Bottom Height [H] of Support Plate

Skirt Width	35° idler	45° idler
6"	2½"	3¼"
8"	3½"	3¾"
10"	3¾"	4¼"
12"	6"	6¼"

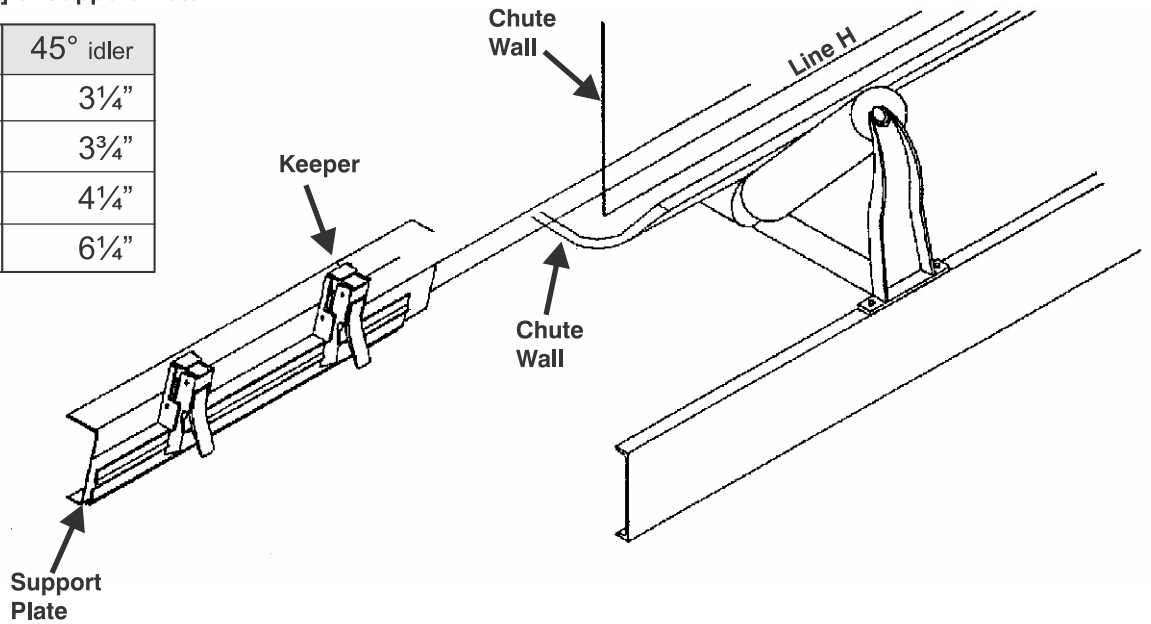

1. Before proceeding with the installation of Clamp Mount with Support Plates, you must remove a small portion of the old skirting system and check that you have at least 1" to 1½", of clearance between the bottom of the chute wall and the belt surface. If you have more than 1½", then, you will have to fill in along the chute wall with more steel to get 1" of clearance.
2. Remove the existing skirting system. If needed, modify the chute for the proper clearances (above). Clean the chute wall at and below the approximate location of the support plates to insure a good weld and correct clamping force onto the sealing compound.
3. Beginning near the tail and working toward the head pulley, measure from the belt surface up the given height [H] from Chart A. As an example, for 6" high sealing compound on 35 degree idlers you would measure up from the belt 2½". Mark the chute wall with [H] every four feet for the length of the skirting required. Connect these marks with a chalkline.
4. Put the bottom lip of the support plate on line [H] and weld it with three equally spaced 2" bead welds **TOP** and **BOTTOM**. Butt the next support plate and continue the process for the length of the skirting system.

NOTE: If there is a gap greater than 1/8" at the and below butt joint (due to an obstruction or change in elevation), cut one of the support plates for a tighter fit.

Installing Clamp Mounts

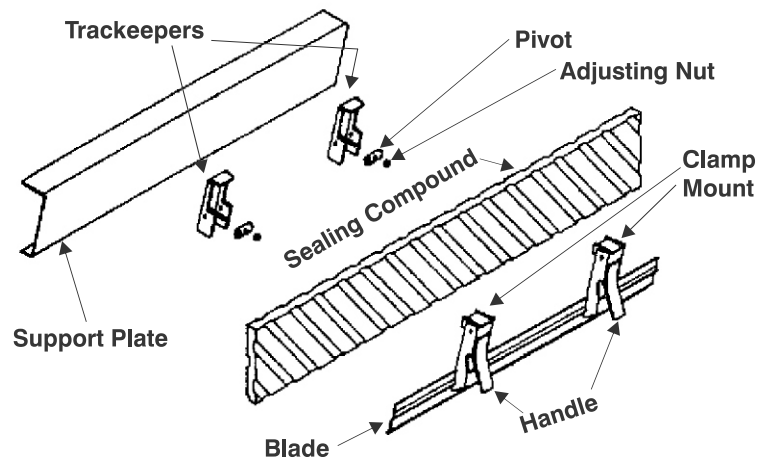

1. At one end of the first Support Plate; place a tape measure on it, measure from the bottom up 5", mark the distance and label it [K]. Repeat the process on the other end of the Support Plate. Draw a line connecting the marks [K] and label it Line K.
2. Assemble one Clamp Mount. Position it with the bottom of the keepers along Line K and one end at the leading edge of the first Support plate (beginning of the skirting system).
3. Mark an outline of the keepers on the Support Plate.
4. Position the keepers within the outline you marked on the chute wall. Beadweld the bottom and sides (and top, if possible) of each keeper to the Support Plate.
5. Repeat the measuring marking and welding process for the complete length of the skirting system.

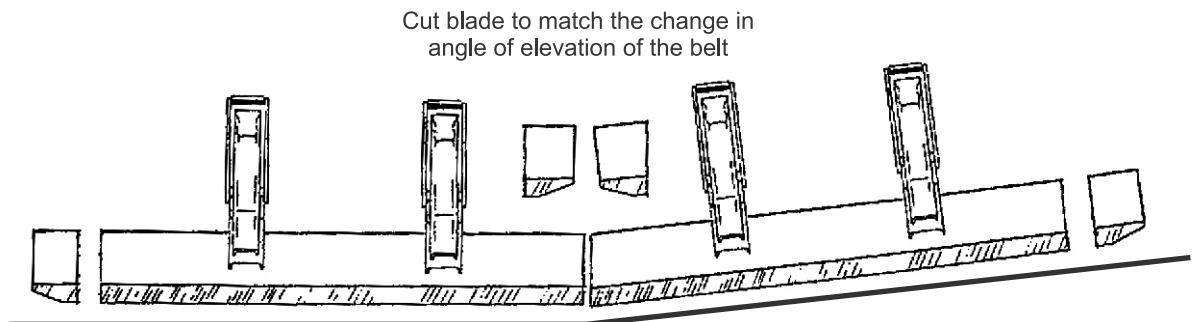

CLAMP MOUNT™ and TRACKKEEPER™

Clamp Mount with Support Plate Instructions

Parts List

Description	Part Number
Clamp Mount I	M-ASG-CT-1
Clamp Mount II	M-ASG-CT-2
Trackkeeper	ASG-TK-1
Track Filler	ASG-TK-TF

Trackkeeper is an adapter that securely fastens the ASGCO Clamp Mount Skirting System to an existing TRAC-MOUNT skirting system.

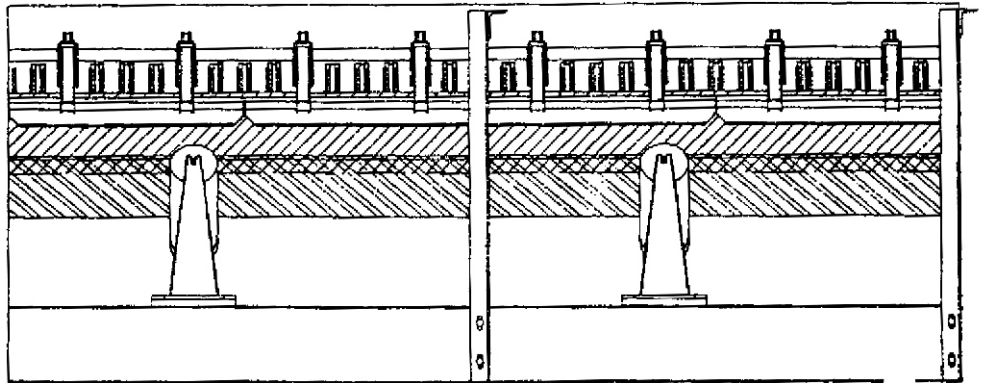

NOTE: The Clamp Mount blade can be shortened to accommodate a change in belt elevation or at the end of the skirting system. However, equal amounts of blade must be cut off each end. Either saw [preferred] or cut [with a torch] off the extra blade section and paint the exposed steel to prevent rusting. The Trackkeepers and Track Fillers are designed to slide into the slots of the TRAC-MOUNT. Trackkeepers have a threaded bolt stud, Track Fillers do not.

Installation Instructions

1. Remove the existing rubber block sealing compound.
2. Begin at the tail [rear] end of the conveyor and hold a Clamp Mount along the TRAC-MOUNT and position one end of the blade where the skirting material will end.
3. Insert a Trackkeeper in the TRAC-MOUNT slots closest to the clamp handle[s]. Clamp Mount I has one handle, Clamp Mount II has two handles.
4. Insert Track Fillers in the other slots.
5. Position the second and additional Clamp Mounts on two foot centers along the conveyor. Install Track Fillers in the open slots.

Installation of Sealing Compound

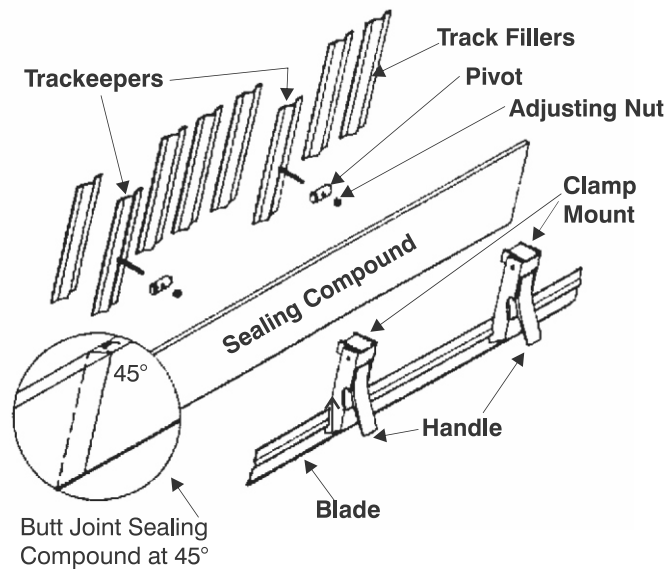

6. Lay the compound on the belt below the keepers. If the compound has a beveled edge, position the compound with the angle of the edge parallel to the belt angle. With a sharp knife, cut the sealing compound to the correct length, preferably in one piece.
7. When more than one length of sealing compound is required, cut the ends at a 45° angle. Position the 45° joint as close as possible to the center of the blade. Always make a 45° joint as smooth as possible. Never locate a 45° joint near the blade end or in the gap between blades.
8. Install the Clamp Mounts onto the Trackkeeper. Position the pivot parallel to the blade, with its protruding ends sitting firmly in the notched portion of the housing. Tighten the adjusting nut to secure the Clamp Mount. Using hand pressure only, close the handle.
9. When all the Clamp Mounts have been installed, position the sealing compound so that it lightly touches the belt. Tighten the adjusting nut with a wrench. If the handle cannot be opened by hand - the adjusting nut is too tight.
10. Adjust the sealing compound by opening one clamp handle at a time and lower or raise compound until it touches the belt lightly, then close the handle.
11. In areas of high vibration or impact; install a locking cotter pin in the keeper after the sealing compound is in position. This will prevent accidental opening of the handle.

Sealing the Rear of the Chute Wall

NOTE: When the belt is angled up at its sides, the blade ends and sealing compound must be trimmed to match the angle of the belt.

IMPORTANT: A minimum 1" clearance is required between the clamp blade and the belt at all points in this installation. If the blade touches the belt, it could damage the belt or foul the operation of the conveyor.

1. Using a Clamp Mount as a measuring device, determine how many will be needed to seal the rear of the chute and how much [if any] of the blade ends must be trimmed off. Remember - equal amounts of blade must be cut off each end. Either saw [preferred] or cut [with a torch] off the extra blade section and paint the exposed steel to prevent rusting.
2. Position the Trackkeepers and Track Fillers according to instructions I through 5.

NOTE: If the sealing compound has a beveled edge, position the leading edge of the compound toward the head pulley.

3. Position the sealing compound according to instructions 9 through 11.

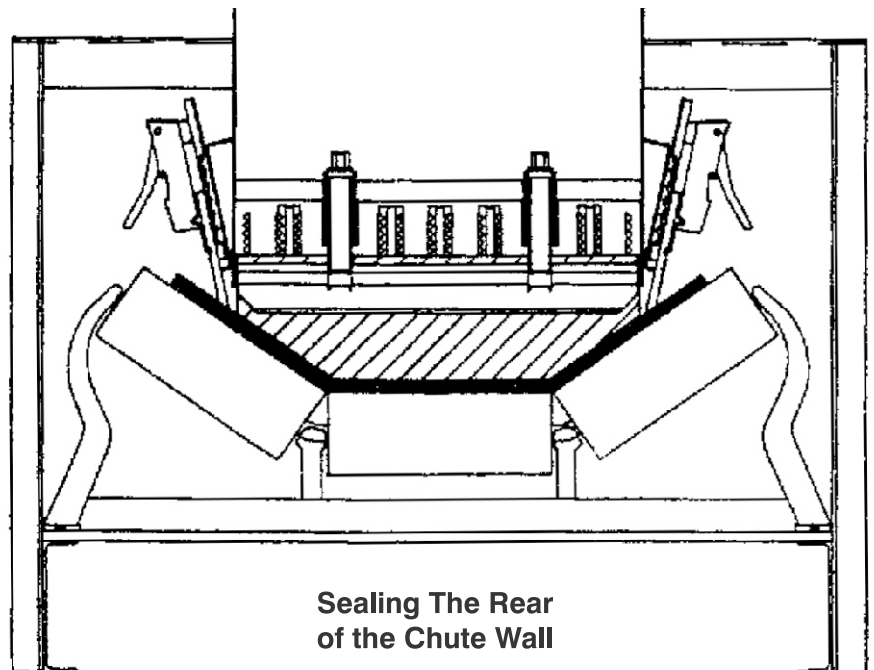

Information

Key	Description	Part Number
1	Clamp Mount I	M-ASG-CT-1
2	Clamp Mount II	M-ASG-CT-2
3	Trackeeper	ASG-TK-1
4	Track Filler	ASG-TK-TF
5	Support Plate	ASG-CZ-10

Call your ASGCO Distributor for any questions or replacement parts

TROUBLE SHOOTING

PROBLEM	SOLUTION
<i>New Sealing Compound Vibrates</i>	At times new sealing compound is installed too tight against the belt and will vibrate until the excess force will also wear the surface of the belt, therefore the sealing compound should be raised until the vibration ceases.
<i>New Sealing Compound Squeals</i>	At times new sealing compound is installed too tight against the belt and will squeal until the excess compound wears away. This excess force will also wear the surface of the belt, therefore the sealing compound should be raised slightly until the squealing ceases.
<i>New Sealing Compound Gets Hot and Smokes</i>	At times new sealing compound is installed too tight against the belt and will smoke due to heat build-up until the excess compound wears away. This excess force will also wear the surface of the belt, therefore the sealing compound should be raised slightly until the smoking ceases.
<i>Material Leakage Between Belt and Sealing Compound</i>	Material and dust leakage is caused by small gaps between the sealing compound and the surface of the belt. Tighten the skirting against the belt.
<i>Skirt Sealing Compound flips to the Outside of the Belt</i>	At times when the sealing compound is installed with the side of the belt flexing the way, at times, mistrack enough that the skirting flips down outside the belt. Train the belt so as not to mistrack or install a training idler just before the belt comes around the tail pulley.