

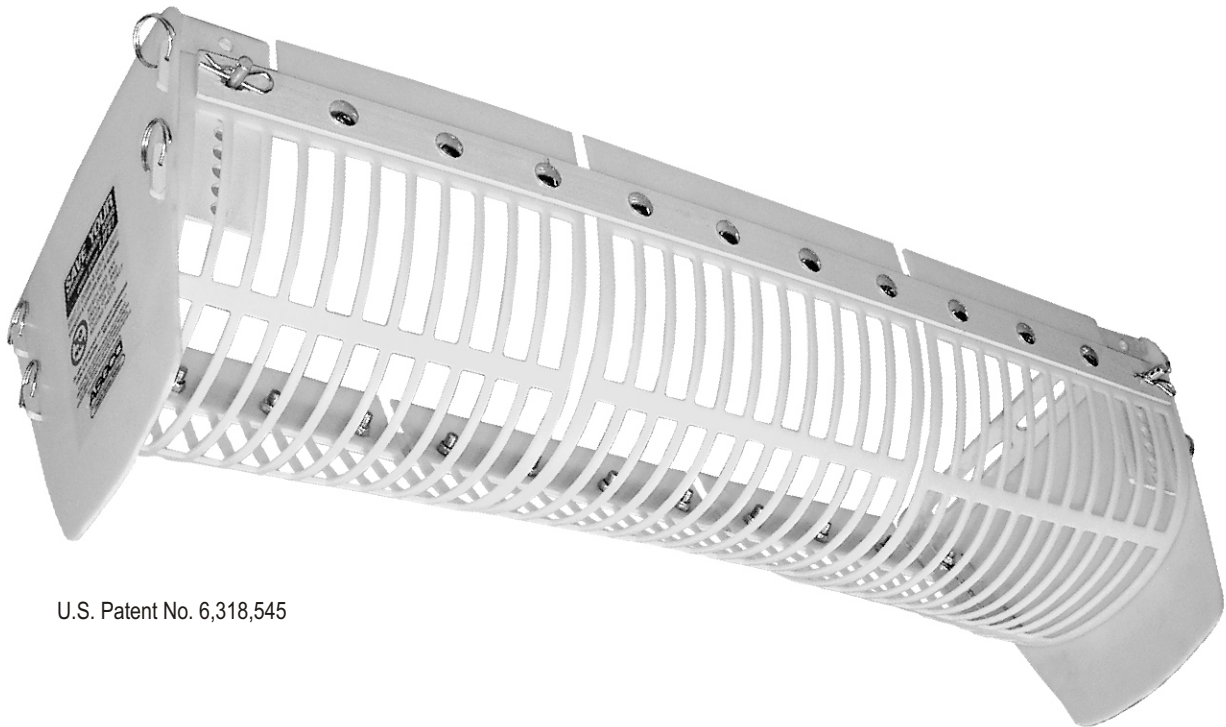

# SAFE-GUARD<sup>®</sup>

## *Return Idler Guard*

# INSTALLATION, OPERATION & MAINTENANCE INSTRUCTIONS



U.S. Patent No. 6,318,545

Check us out at  
[www.asgco.com](http://www.asgco.com)

Customer Service  
**800-344-4000**



24 Hour Emergency  
Service and Parts  
610-821-0210



ASGCO Mfg., Inc.  
301 Gordon Street  
Allentown, PA 18102  
610-821-0216  
FAX 610-778-8991

---

**Important  
Safety  
Notice**

*Always observe the basic rules of safety when working with any conveyor system. To avoid injury and equipment damage, be sure that all controls to the conveyor are locked out and the power source is disconnected at all times during installation.*

---

**WARNING:**

PLEASE COMPLETELY READ AND UNDERSTAND THESE INSTRUCTIONS BEFORE ATTEMPTING THE INSTALLATION OF AN ASGCO SAFE-GUARD RETURN IDLER GUARD. FAILURE TO DO SO COULD LEAD TO SERIOUS INJURY AND EQUIPMENT DAMAGE. ENSURE THAT ALL CONTROLS AND POWER SOURCES TO THE CONVEYOR SYSTEM ARE PROPERLY DISCONNECTED AND LOCKED OUT WHILE INSTALLING, CLEANING OR MAINTAINING THE SAFE-GUARD. NEVER ATTEMPT ANY INSTALLATION, OR SERVICE PROCEDURE WHILE THE CONVEYOR IS IN OPERATION.

**WARNING:**

THE SAFE-GUARD RETURN IDLER GUARD IS DESIGNED TO RESTRICT CONTACT WITH THE RETURN IDLER WHILE THE CONVEYOR IS RUNNING. INSTALLATION OF THIS GUARD DOES NOT SUPERSEDE ANY OTHER SAFETY PROCEDURES OR SAFETY PRACTICES. FAILURE TO OBSERVE ALL INSTRUCTIONS COULD RESULT IN SERIOUS INJURY. IT IS THE OWNER'S RESPONSIBILITY THAT THE OWNER AND EACH OPERATOR READ AND BE FAMILIAR WITH THIS MANUAL. CAUTION: IT IS THE OWNER'S RESPONSIBILITY TO ADJUST THE SAFE-GUARD RESTRICTING ALL CONTACT WITH THE TURNING IDLER.

PLEASE CONTACT THE ENGINEERING DEPARTMENT AT ASGCO MANUFACTURING AT 800.344.4000 IF YOU HAVE FURTHER QUESTIONS OR ARE UNSURE OF THESE PROCEDURES.

## 1. Identify and Become Familiar With All Parts.

Ensure all parts have been included.

ITEM NO.	QTY.	DESCRIPTION	MATERIAL SPECIFICATION
1	1	LEFT MOUNTING BRACKET	FABRICATED STEEL
2	1	RIGHT MOUNTING BRACKET	FABRICATED STEEL
3	2	GRID BRACKET	FABRICATED STEEL
4	2	END UHMW GRID	SAFETY YELLOW UHMW
5	*	NARROW UHMW GRID	SAFETY YELLOW UHMW
6	*	WIDE UHMW GRID	SAFETY YELLOW UHMW
7	2	UHMW SIDE COVER	SAFETY YELLOW UHMW
8	2	3/8-16 X 1" GRADE 5 BOLT	ZINC PLATED STEEL
9	*	3/8-16 NYLOCK NUT	ZINC PLATED NYLON INSERT NUT
10	4	3/8 FLAT WASHER	ZINC PLATED STEEL
11	*	3/8-16X 1" CARRIAGE BOLT	ZINC PLATED STEEL
12	2	3/8 X 1 1/2 ADJUSTABLE CLEVIS PIN	ZINC PLATED STEEL
13	2	.125 X 1 15/16 HAIR PIN	ZINC PLATED STEEL
14	8	1 1/8 CIRCLE COTTER	.072 DIA STAINLESS STEEL

\* INDICATES QUANTITY CHANGES WITH GUARD SIZE

## 2. Mounting the Left and Right Mounting Bracket

Bolt the safety yellow UHMW grids to the two Grid Holder brackets using the 1/4-20 flathead elevator bolts, flat washer and 1/4-20 NYLOC nuts provided. Be sure to start at the second hole in from the end.

*NOTE: These items may come pre-assembled.*

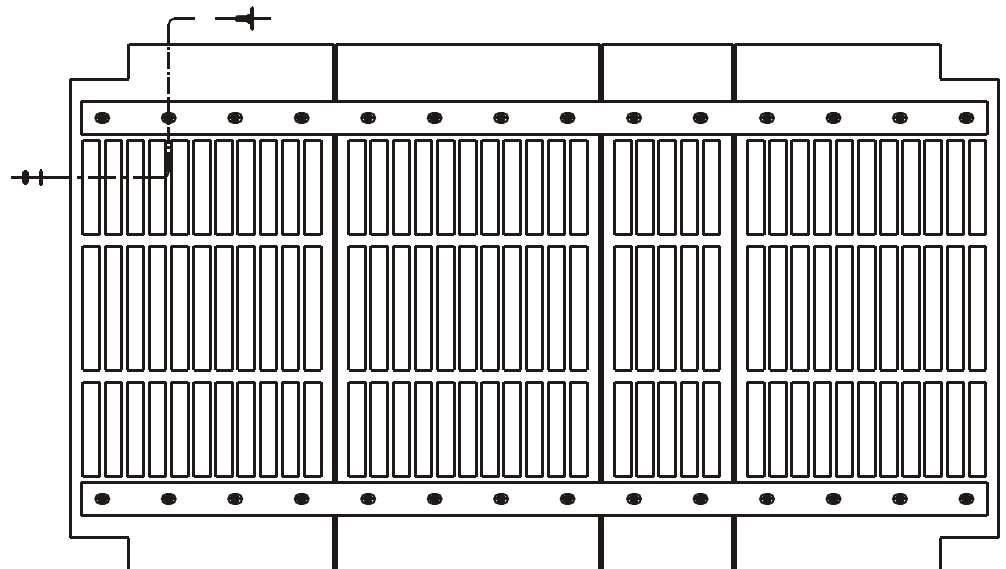

## SAFETY YELLOW UHMW GRID LAYOUT

BELT WIDTH	18	24	30	36	42	48	54	60	72
NOTCHED	2	2	2	2	2	2	2	2	2
12" WIDE	0	1	1	2	2	3	3	4	5
6' WIDE	1	0	1	0	1	0	1	0	0

### 3. Mount the Left and Right Mounting Brackets

The mounting brackets are designed so they can be mounted using the same bolts that hold the idler mounting bracket in place without dropping the idler.

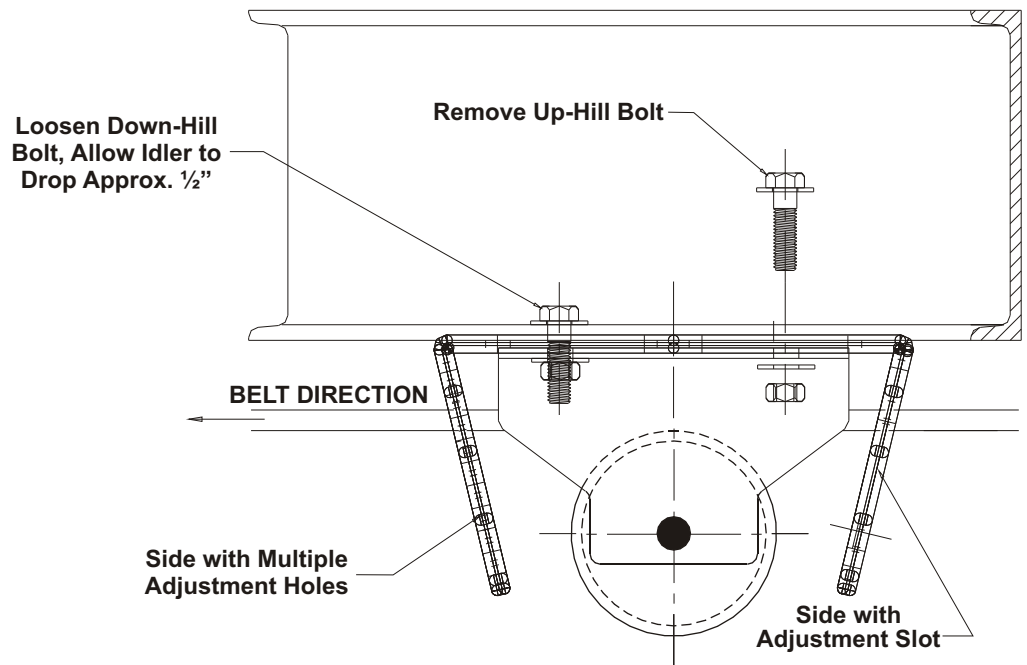

The mounting brackets are slotted on one side so the bracket can slide over top of the idler bracket with the down stream bolt still in place. The up stream bolt should be removed then returned once the SAFEGUARD mounting bracket is in place. Make sure the four tabs on the mounting bracket are facing away from the conveyor belt.

### CAUTION:

Install the mounting brackets on side at a time to ensure the idler is secure and can not drop.

#### 4. Attach the **SAFE-GUARD** Grids to the Mounting Bracket

Attach the grid assembly to the already installed mounting brackets using two (2) 3/8-16 X 1" bolts, NYLOC nuts and washers provided.

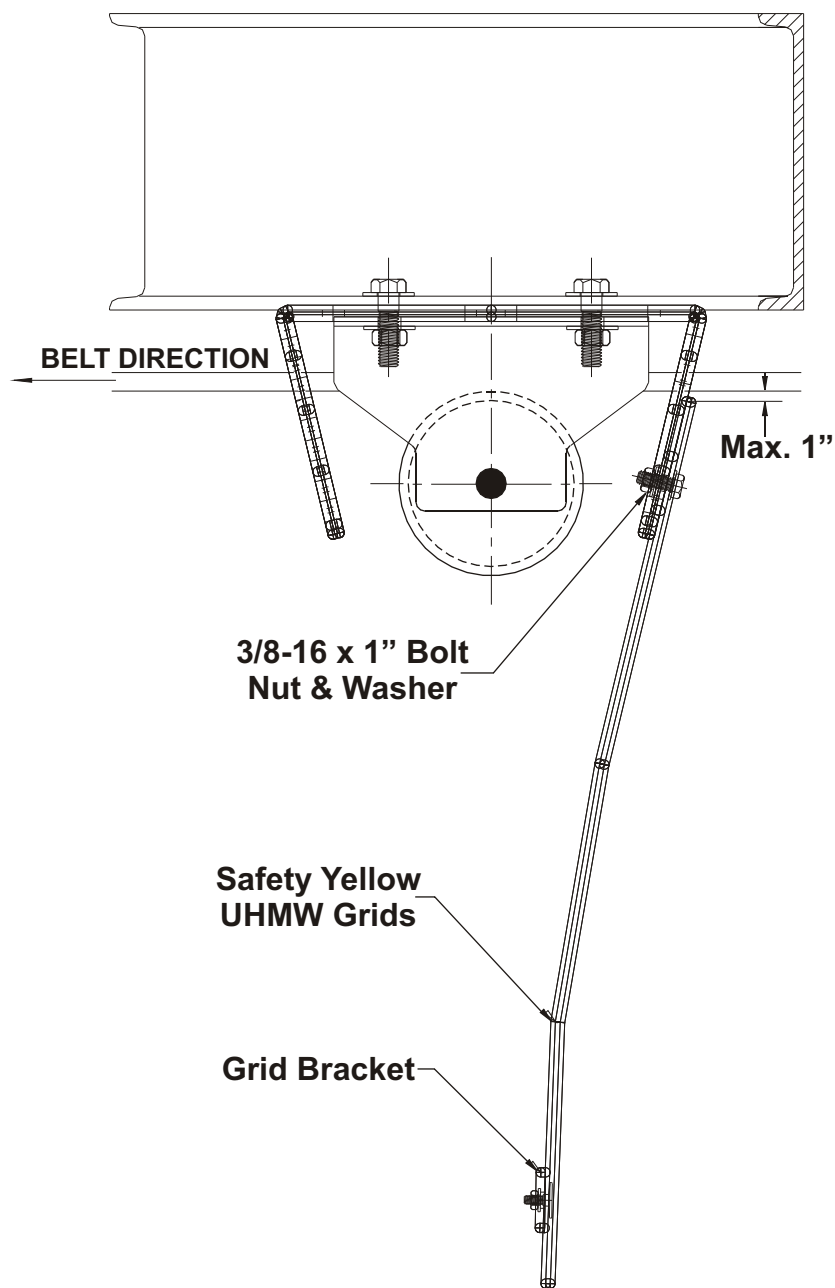

Mount the assembly as shown allowing no more Than 1" between the top of the UHMW grids and the conveyor belt. We recommend the use of a MSHA Approved GO-NO-GO gage to ensure proper adjustment.

## 5. Attach the SAFE-GUARD Grids to the Opposite Side

Attach the grid assembly to the already installed mounting brackets using two (2) 3/8-16 X 1" bolts, NYLOC nuts and washers provided.

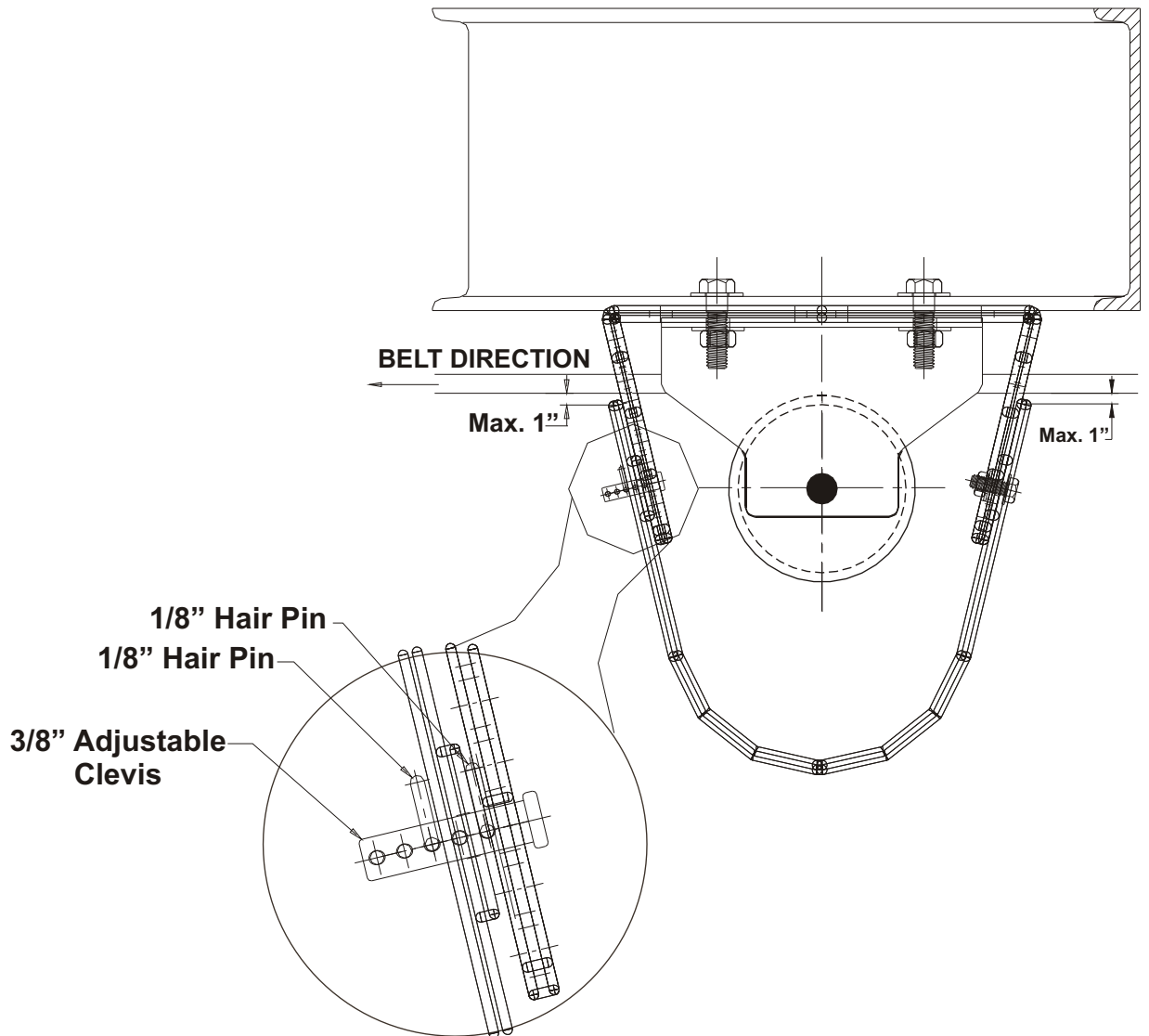

Bring the already attached grid assembly around to the other side of the SAFE-GUARD mounting brackets. Hold the grid assembly in place so that the top edge of the UHMW is approximately 1" from the conveyor belt. Line the holes on the grid mounting bar with the multiple adjustment holes on the mounting bracket. Once your hole is determined, place the 3/8" adjustable clevis in the mounting bracket hole from the inside facing out, and place one hair pin through the first clevis hole closest to the mounting bracket. This will keep the clevis in place when future maintenance is done. Next bring the grid assembly back into place over the clevis pin as shown above. Place the second hairpin in the next available hole. This should be the third hole from the end of the clevis. Perform this step on both sides of the SAFE-GUARD assembly.

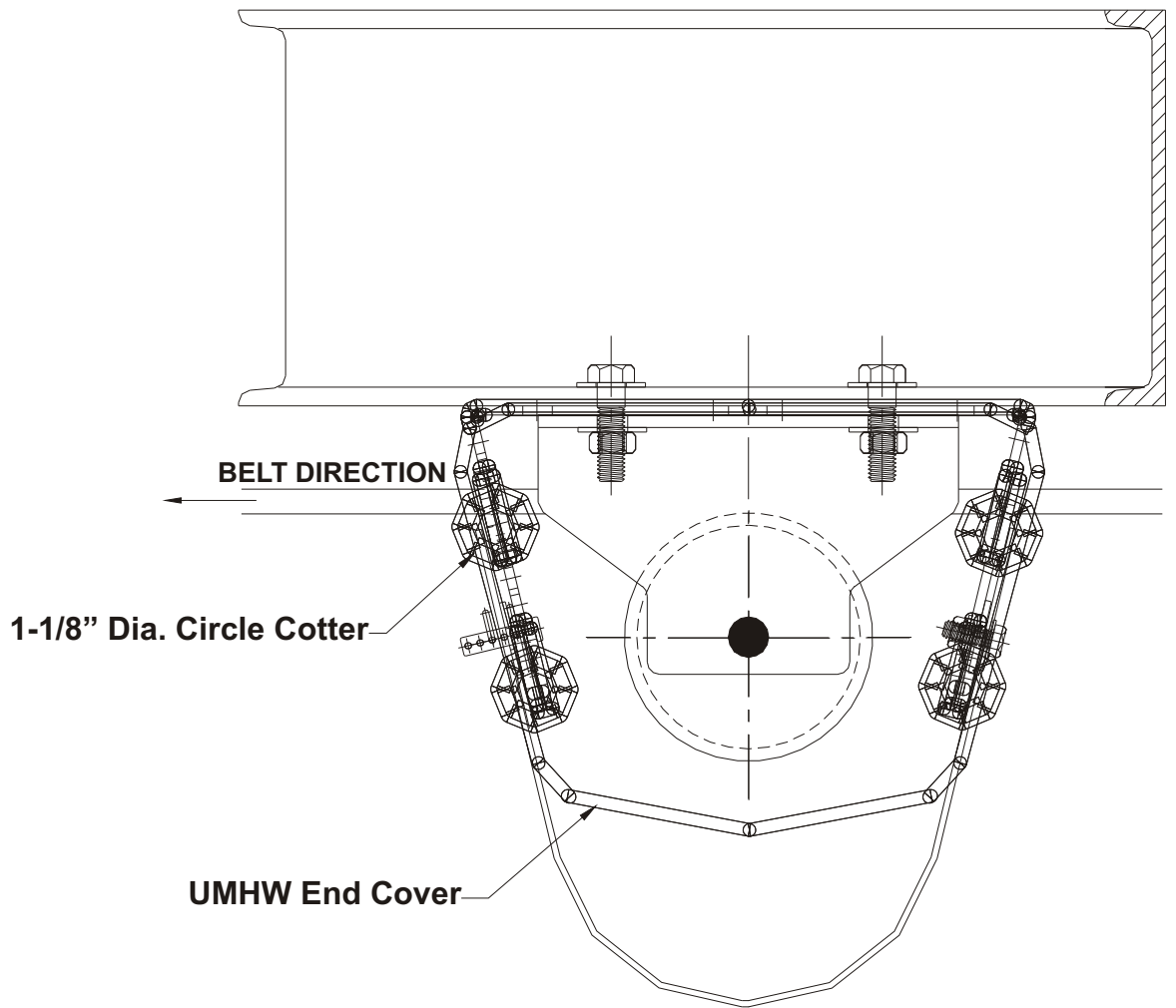

Slide the Safety Yellow UHMW End Covers over the tabs that are on the SAFE-GUARD Mounting Brackets and push down. The End Covers should slide down behind the tabs. Next place a Circle Cotter

---

## **OPERATION & MAINTENANCE**

The UHMW Grid portion of the SAFE-GUARD is made from 1/8" Thick UV Stabilized UHMW and is resistant to most types of corrosion. The steel components are all Powder Coated A-36 Steel and should last indefinitely. All hardware and fasteners are zinc plated.

- The grids are designed to prevent any appendages from being caught in the idler/belt contact point or any other catch points and still allow most material and debris to pass through. The guards should be inspected regularly for material build-up that would hinder idler performance.
- The guards should be checked on a regular schedule for damage due to abrasion or impact.

## Information

SAFE-GUARD PART NUMBER	BELT WIDTH (INCHES)	A INCHES	B INCHES
M-ASG-RRG-18	18	27	30.5
M-ASG-RRG-24	24	33	36.5
M-ASG-RRG-30	30	39	42.5
M-ASG-RRG-36	36	45	48.5
M-ASG-RRG-42	42	51	54.5
M-ASG-RRG-48	48	57	60.5
M-ASG-RRG-54	54	63	66.5
M-ASG-RRG-60	60	69	72.5
M-ASG-RRG-66	66	75	78.5
M-ASG-RRG-72	72	81	84.5
M-ASG-RRG-84	84	93	96.5
M-ASG-RRG-96	96	105	108.5

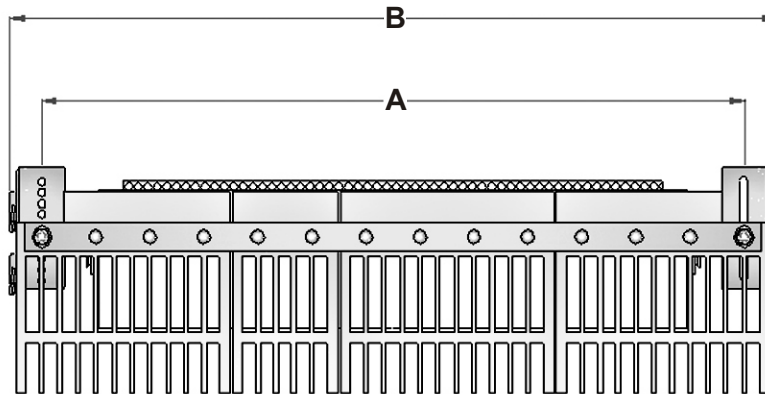

*Call your ASGCO Distributor for any questions or replacement parts*

### Warranty

ASGCO Manufacturing, Inc., warrants its products to be free from defects in material and workmanship under normal use and service, its obligation under this warranty being limited to replacement of any defective product if returned by the purchaser, or refunding of the purchase price, at ASGCO's discretion. ASGCO shall not be liable for incidental or consequential damages and including, but not limited to, claims for down time, lost profits, and/or business overhead expenses. THIS WARRANTY IS IN LIEU OF ALL OTHER WARRANTIES, EXPRESS OR IMPLIED, AND EXPRESSLY EXCLUDES ANY WARRANTY OF MERCHANTABILITY OR FITNESS FOR ANY PARTICULAR PURPOSE.

ASGCO is a registered trademark of ASGCO Manufacturing, Inc.  
SAFE-GUARD is a trademark of ASGCO Manufacturing, Inc.

All information in this publication is based on the latest product information available at the time of printing. ASGCO Manufacturing, Inc. reserves the right to make changes on or add improvements upon its products at any time without notice or obligation.