

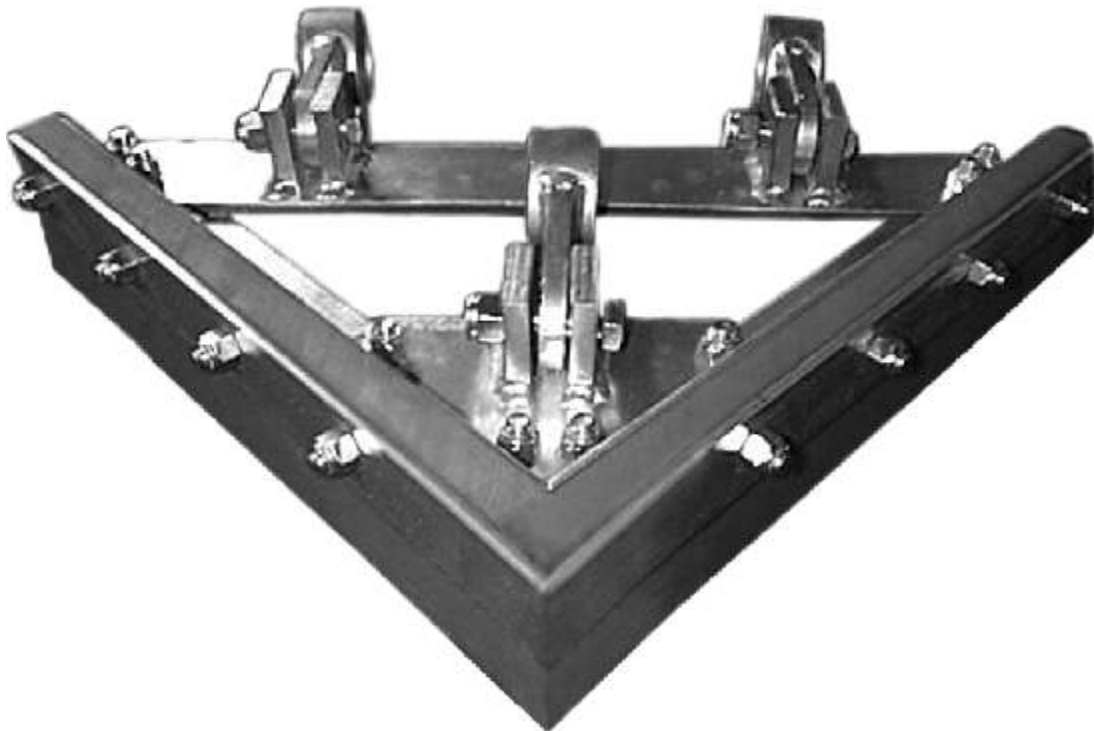

# RETURN V-PLOW

## INSTALLATION, OPERATION & MAINTENANCE INSTRUCTIONS



Check us out at  
[www.asgco.com](http://www.asgco.com)

Customer Service  
**800-344-4000**



24 Hour Emergency  
Service and Parts  
610-821-0210



ASGCO Mfg., Inc.  
301 Gordon Street  
Allentown, PA 18102  
610-821-0216  
FAX 610-778-8991

---

**Important  
Safety  
Notice**

Always observe the basic rules of safety when working with any conveyor system. To avoid injury and equipment damage, be sure that all controls to the conveyor are locked out and the power source is disconnected at all times during installation. Keep a fire extinguisher and a first-aid kit on hand at all times.

**VERY IMPORTANT:** To avoid serious injury, be sure that all controls to the conveyor system are locked out and the power source is disconnected at all times while working on the belt cleaner or tensioning system on the cleaner.

**Never attempt any installation or service procedure with the power turned on.**

---

**Installation  
Tools**

In addition to items supplied by ASGCO, you will need the following to install a V-Plow Belt Cleaner:

Welding Equipment  
Burning Equipment  
Soap Stone

Adjustable Wrench  
Tape or Folding Rule  
Square

---

**Components  
Diagram**

**THE PARTS SHOWN BELOW SHOULD BE PROVIDED**

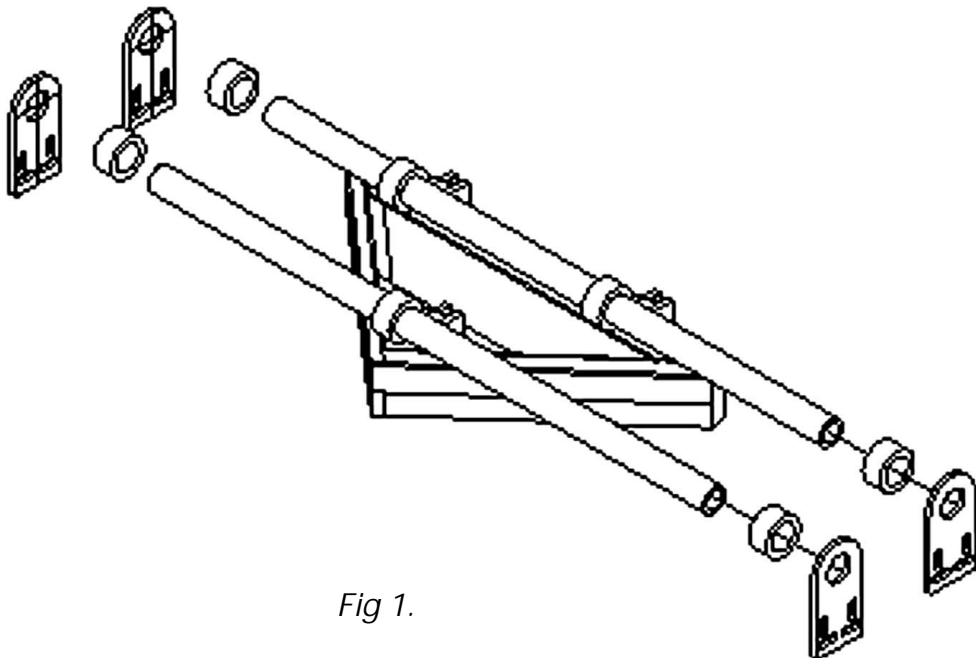

Fig 1.

# V-PLOW INSTALLATION

Before starting any work, please study all of the instructions. ASGCO suggests that you first examine the drawings. Then read the instructions.

When you install the V-Plow, follow each instruction carefully and complete the steps in the numbered order. That way, the job will go easily and smoothly, and mistakes and rework can be avoided.

## Instructions

**Step 1** Select a suitable location just before a tail pulley or a take-up pulley. The purpose of the plow is to deflect material from the belt that would normally be caught between the belt and a pulley, causing damage to the belt. Normally the plow is located on the clean side of the belt between the toughed run and the return run of the belt.

**Step 2** Mount the return side V-Plow so that the center of the support tubes are about 6 3/4" to 7" above the belt as shown in Fig. 2. This will insure that the steel frame will not contact the belt when the rubber plow surface wears

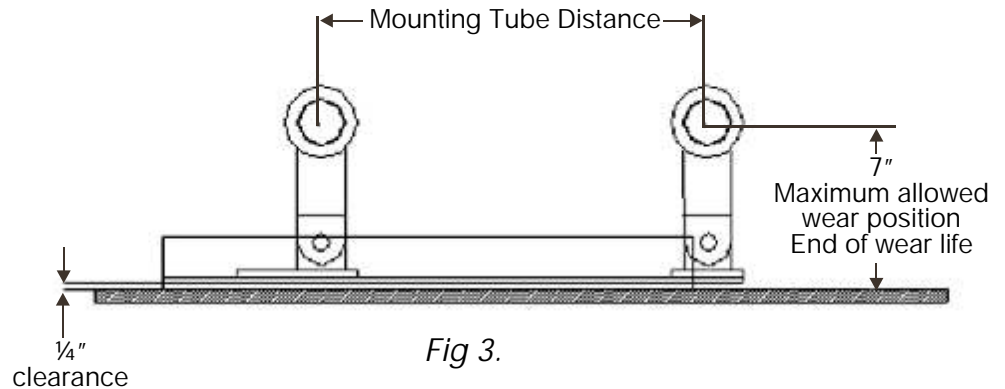

## Mounting Tube Distance Chart

BELT WIDTH	MOUNTING TUBE DIST.	BELT WIDTH	MOUNTING TUBE DIST.
18	4-13/16"	54	22-5/8"
24	7-5/16"	60	25-3/16"
30	10-5/16"	72	31-3/16"
36	13-5/16"	84	31-3/16"
42	16-5/16"	96	45"
48	19-5/16"		

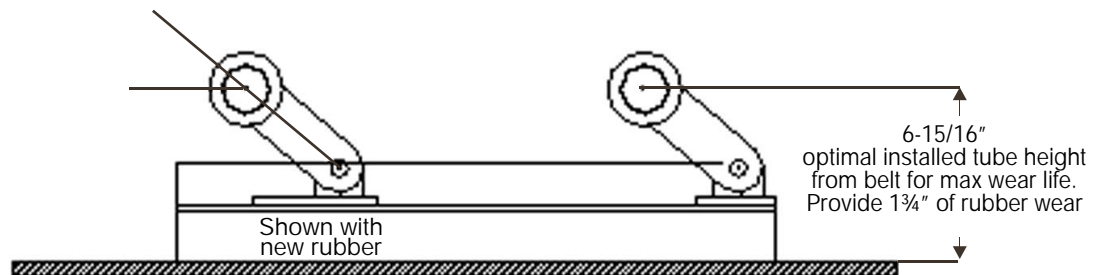
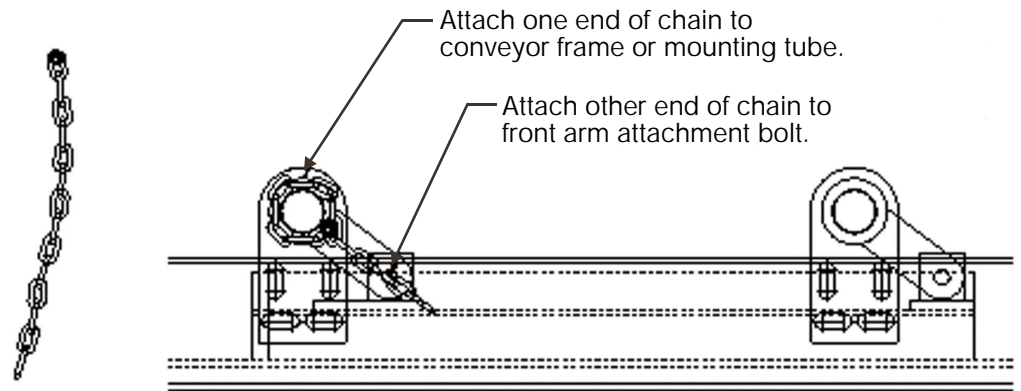

Fig 4.

**Step 1** Assemble the plow into position in the conveyor frame as shown in Fig. 1. The plow is tensioned into the belt by gravity, when the three connecting rods are hanging straight down it will be time to change the rubber on the plow. The collars on the mounting tubes may be located inside or outside of the mounting plate. Their only purpose is to prohibit the shaft from lateral movement.

**Step 2** In some instances a safety chain has been supplied and should be installed as shown in fig. 4 shown below. The length of the chain should be adjusted so



*Fig 4.*

---

## Information

### V-Plow Replacement Parts (1" X 4" Rubber)

Part Number	Belt Width	Cleaning Surface	Wt. #
ADS-RU55-2544-18	18	20	3.27
ADS-RU55-2544-24	24	26	4.28
ADS-RU55-2544-30	30	32	5.41
ADS-RU55-2544-36	36	38	6.42
ADS-RU55-2544-42	42	44	7.55
ADS-RU55-2544-48	48	50	8.56
ADS-RU55-2544-54	54	56	9.56
ADS-RU55-2544-60	60	62	10.7
ADS-RU55-2544-72	72	74	12.84
ADS-RU55-2544-84	84	86	14.97
ADS-RU55-2544-96	96	98	17.11

---

## MAINTENANCE

After one day  
of operation:

- 1.) Inspect the plow for proper belt cleaning and operation.

---

Weekly:

- 1.) Frequent inspection is the key to proper belt cleaning and easy Plow servicing. Weekly inspections are recommended, but actual service frequency may vary widely depending on various plant operating conditions.
- 2.) Wash the entire Plow regularly to prevent excessive buildup. If material tends to accumulate on the Plow Assembly then possible plow relocation may be in order.
- 3.) Inspect the plow rubber. Make sure the rubber is not worn out.
- 4.) Inspect the belt surfaces and edges for cracks, splits, tears, holes or any other worn or damaged condition occurring on the surfaces or edges of the belt itself. If necessary make repairs to the belt.

---

## REPLACEMENT OF PLOW RUBBER

1. Remove plow from the conveyor frame.
- 2.) Remove the bolts holding the worn out rubber in place and remove the worn out rubber.
- 3.) Attach the replacement rubber to the plow frame.
- 4.) Reinstall the plow into the conveyor frame.

## TROUBLE SHOOTING

PROBLEM	SOLUTION
<b><i>Excess vibration of the plow.</i></b>	Make certain all bolts are tight.  Make sure the belt is not vibrating, return roller may have to be placed under the belt to stop the vibration.
<b><i>Unable to tension scraper properly, belt moves away from plow.</i></b>	Install a hold down roller to reduce sag of the belt.
<b><i>Frozen material on scraper.</i></b>	Place heaters near plow to melt frozen material. <i>(Use caution not to burn belt or cleaner)</i>