

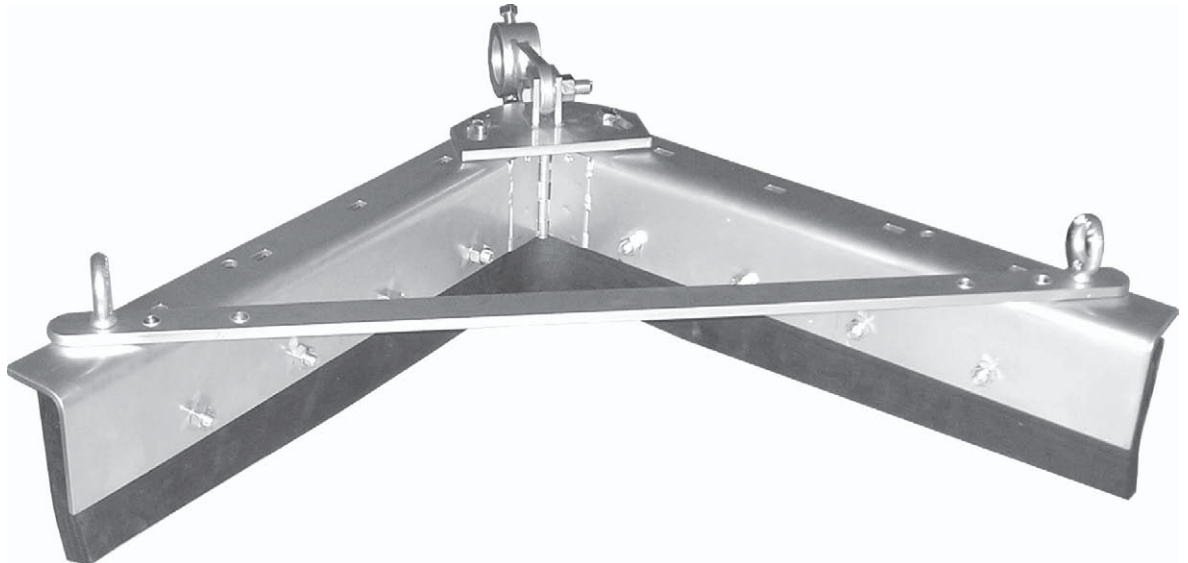

RETURN PREMIUM HINGED V-PLOW

INSTALLATION, OPERATION & MAINTENANCE INSTRUCTIONS

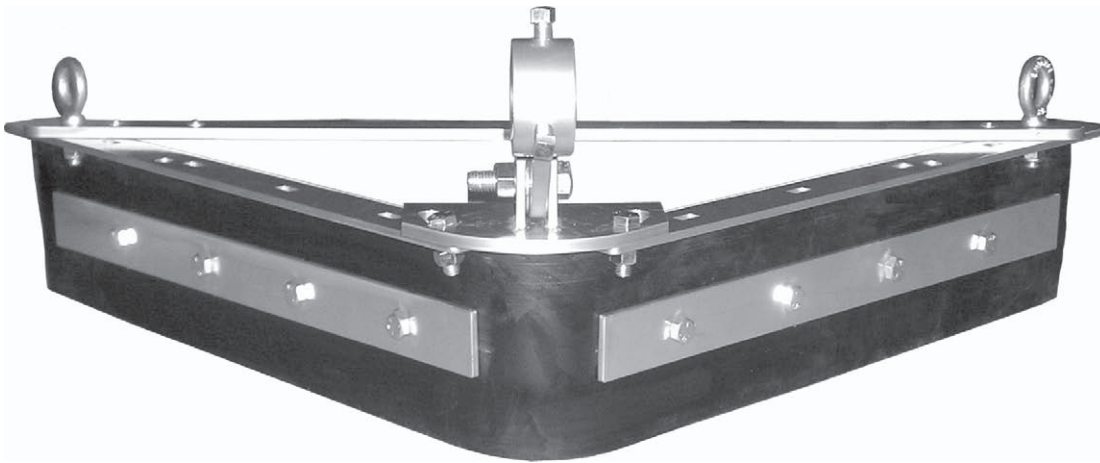

Check us out at
www.asgco.com

Customer Service
800-344-4000

24 Hour Emergency
Service and Parts
610-821-0210



ASGCO Mfg., Inc.
301 Gordon Street
Allentown, PA 18102
610-821-0216
FAX 610-778-8991

Important Safety Notice

Always observe the basic rules of safety when working with any conveyor system. To avoid injury and equipment damage, be sure that all controls to the conveyor are locked out and the power source is disconnected at all times during installation. Keep a fire extinguisher and a first-aid kit on hand at all times.

VERY IMPORTANT: To avoid serious injury, be sure that all controls to the conveyor system are locked out and the power source is disconnected at all times while working on the belt cleaner or tensioning system on the cleaner.

Never attempt any installation or service procedure with the power turned on.

Installation Tools

In addition to items supplied by ASGCO, you will need the following to install a V-Plow Belt Cleaner:

Welding Equipment
Burning Equipment
Soap Stone

Adjustable Wrench
Tape or Folding Rule
Square

Components Diagram

THE PARTS SHOWN BELOW SHOULD BE PROVIDED

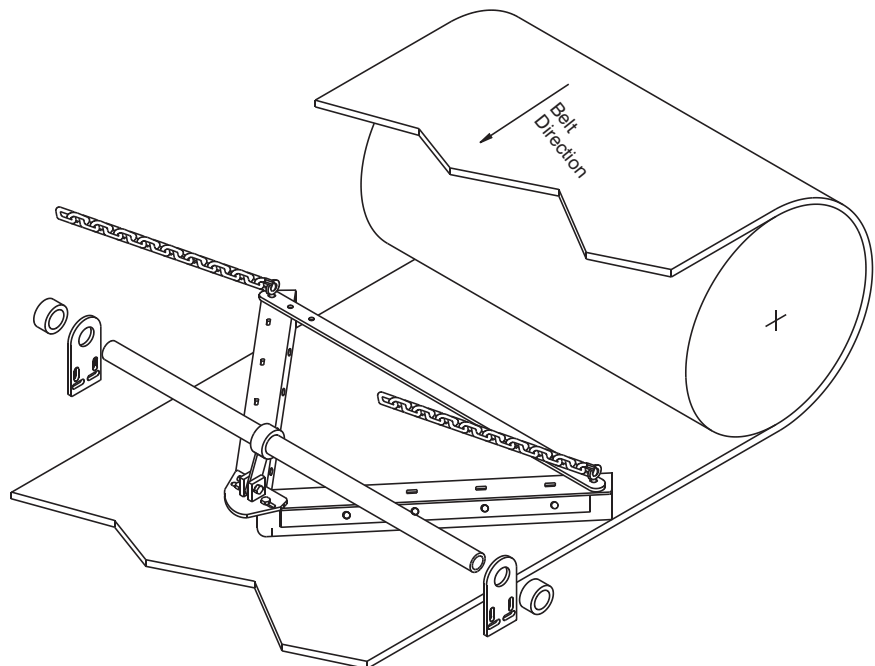

Fig 1.

V-PLOW INSTALLATION

Before starting any work, please study all of the instructions. ASGCO suggests that you first examine the drawings. Then read the instructions.

When you install the V-Plow, follow each instruction carefully and complete the steps in the numbered order. That way, the job will go easily and smoothly, and mistakes and rework can be avoided.

Installation Instructions

- Step 1a.** Select a suitable location just before a tail pulley or a take-up pulley. The purpose of the plow is to deflect material from the belt that would normally be caught between the belt and a pulley, causing damage to the belt. Normally the plow is located on the clean side of the belt between the troughed run and the return run of the belt.
- Step 1b.** Mount the return side V-plow so that the center of the support tube is about 10 1/8" above the belt as shown in Fig 2. This will give roughly 1/4" of space between the belt and the bottom of the V-plow. This will assure that the steel frame will not contact the belt when the rubber plow surface wears.

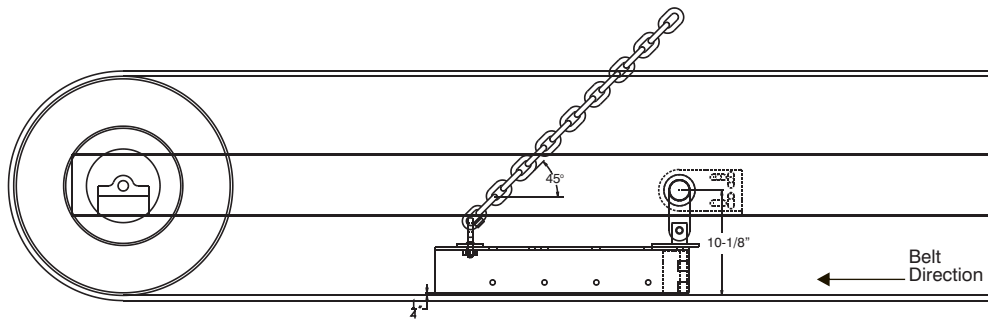

Fig 2 - No Rubber Installed

- Step 1c.** Take the supplied chain and quick connect links and mount the chain so that it makes a 45° angle and that the chain is taught. In addition make sure that there is still a 1/4" distance between the belt and bottom of V-plow. This chain will allow for keeping the V-plow taught as the belt wears and allow for the correct length of chain to be used. Please refer to Chart 1 for hole reference for 45° angles.

Chart 1

ANGLE HOLDER HOLES			
PLOW DESIGNATION	CAPABLE BELT SIZE	HOLE	ANGLE
18"	18"	1	45
24"	24"	1	45
	18"	2	57
30"	30"	1	45
	24"	2	61
36"	36"	1	45
	30"	2	53
	24"	3	61
42"	42"	1	45
	36"	2	53
	30"	3	61
48"	48"	1	45
	42"	2	52
	36"	3	57
54"	54"	1	45
	48"	2	55
	42"	3	60
60"	60"	1	45
	54"	2	50
	48"	3	55
72"	72"	1	45
	60"	2	54
	54"	3	58
84"	84"	1	45
	72"	2	53
	60"	3	59
96"	96"	1	45
	84"	2	52
	72"	3	58

Fig 3

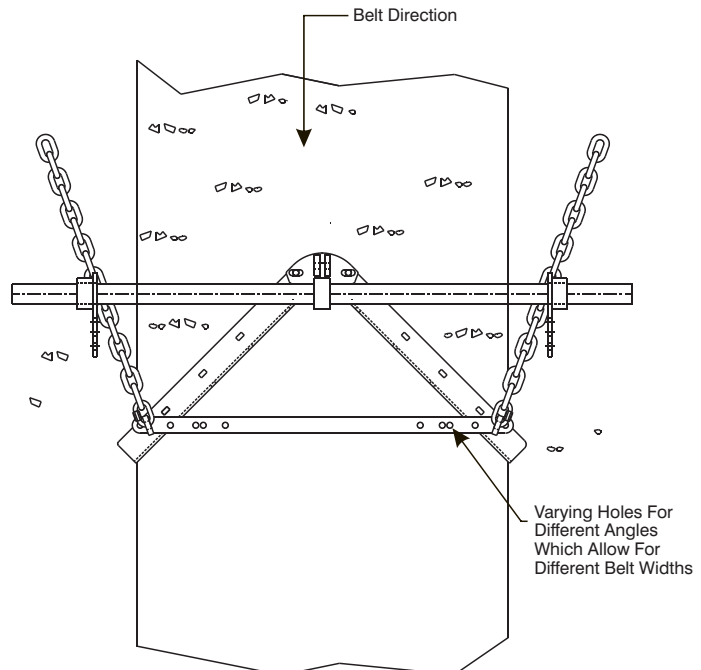

**Install Step 2.
Rubber Installed**

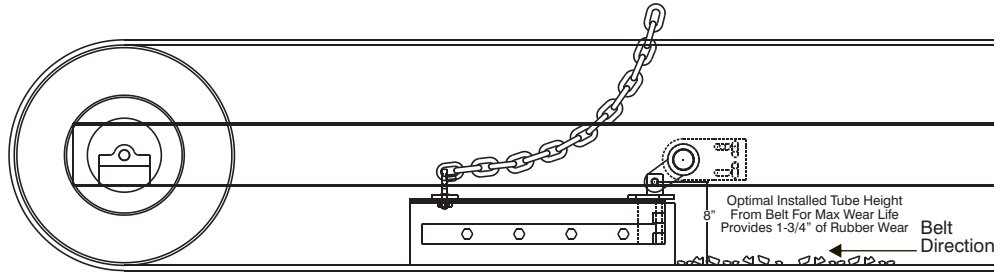

Fig 4 - Rubber Installed

Step 2a. Assemble the plow into position in the conveyor frame as shown in Fig. 1. The plow is tensioned into the belt by gravity. When the chain is roughly in the 45° angle and the connecting rod is vertical it is then time to change the rubber on the plow. The collars on the mounting tube may be located inside or outside of the mounting plate. Their only purpose is to prohibit the shaft from lateral movement.

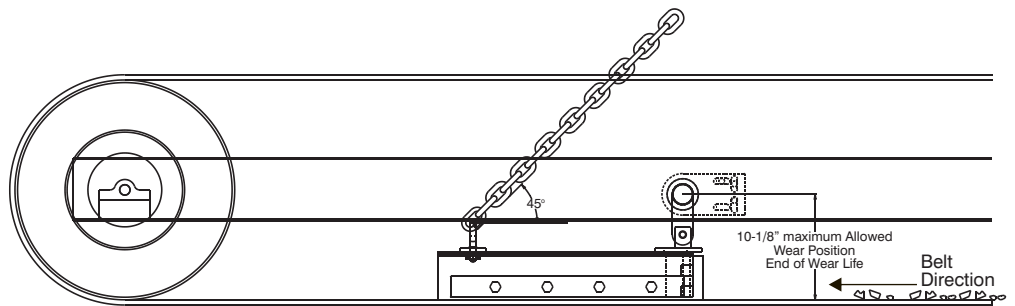

Fig 5 - Worn Rubber

Step 2b. In some instances a safety chain has been supplied and should be installed as shown in fig. 5 shown above. The length of the chain should be adjusted so that the front end of the plow cannot contact the surface of the belt which is roughly 1/4".

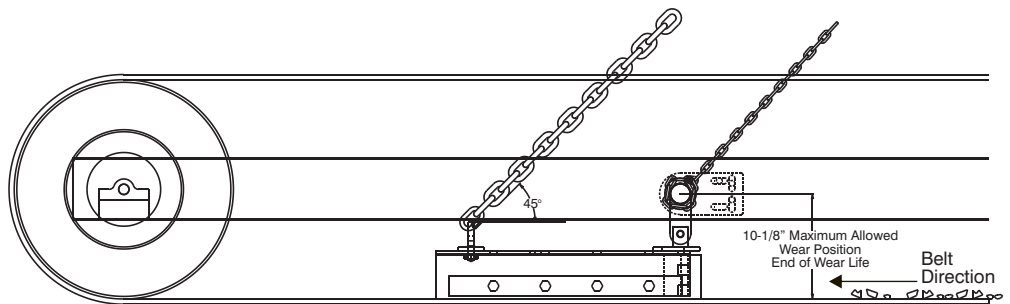

Fig 6 - Safety Chains

Step 2c. For installations which have winged pulleys it may be necessary to install a return roller in the middle of the V-plow and tail pulley. This will help with the inherent vibration, which accompanies these types of pulleys and will allow the V-plow to work more efficiently.

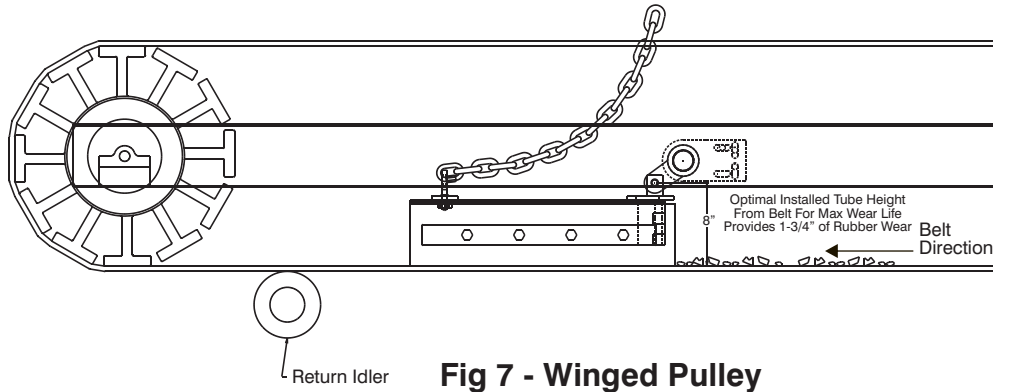

Fig 7 - Winged Pulley

Information

Premium V-Plow Replacement Parts (1" X 6" Rubber)

Part Number	Belt Width	Cleaning Surface	Wt. #
ASG-SS60-1X6-2.5	18	20	3.27
ASG-SS60-1X6-3.0	24	26	4.78
ASG-SS60-1X6-3.5	30	32	5.41
ASG-SS60-1X6-4.5	36	38	6.42
ASG-SS60-1X6-5.0	42	44	7.55
ASG-SS60-1X6-6.0	48	50	8.56
ASG-SS60-1X6-6.5	54	56	9.56
ASG-SS60-1X6-7.5	60	62	10.70
ASG-SS60-1X6-8.5	72	74	12.81
ASG-SS60-1X6-10.0	84	86	14.97
ASG-SS60-1X6-11.5	96	98	17.11

Call your ASGCO Distributor for any questions or replacement parts

MAINTENANCE

After one day of operation:

- 1.) Inspect the plow for proper belt cleaning and operation.

Weekly:

- 1.) Frequent inspection is the key to proper belt cleaning and easy Plow servicing. Weekly inspections are recommended, but actual service frequency may vary widely depending on various plant operating conditions.
- 2.) Wash the entire Plow regularly to prevent excessive buildup. If material tends to accumulate on the Plow Assembly then possible plow relocation may be in order.
- 3.) Inspect the plow rubber. Make sure the rubber is not worn out.
- 4.) Inspect the belt surfaces and edges for cracks, splits, tears, holes or any other worn or damaged condition occurring on the surfaces or edges of the belt itself. If necessary make repairs to the belt.

REPLACEMENT OF PLOW RUBBER

1. Remove plow from the conveyor frame.
- 2.) Remove the bolts holding the worn out rubber in place and remove the worn out rubber.
- 3.) Attach the replacement rubber to the plow frame.
- 4.) Reinstall the plow into the conveyor frame.

TROUBLE SHOOTING

PROBLEM	SOLUTION
<i>Excess vibration of the plow.</i>	Make certain all bolts are tight. Make sure the belt is not vibrating, return roller may have to be placed under the belt to stop the vibration.
<i>Unable to tension scraper properly, belt moves away from plow.</i>	Install a hold down roller to reduce sag of the belt.
<i>Frozen material on scraper.</i>	Place heaters near plow to melt frozen material. <i>(Use caution not to burn belt or cleaner)</i>