

**ASGCO**

Complete Conveyor Solutions

# TRU-TRAINER TRAINING IDLERS

FLAT RETURN / DUAL RETURN / TROUGH TRAINER

## INSTALLATION, OPERATION & MAINTENANCE INSTRUCTIONS



ASGCO Troughing  
Tru-Trainer Training Idler



ASGCO Flat Return  
Tru-Trainer Training Idler



ASGCO Dual Return  
Tru-Trainer Training Idler

Check us out at  
[www.asgco.com](http://www.asgco.com)

Customer Service  
**800-344-4000**



24 Hour Emergency  
Service and Parts  
610-821-0210



ASGCO Mfg., Inc.  
301 Gordon Street  
Allentown, PA 18102  
610-821-0216  
FAX 610-778-8991

## Important Safety Notice

*Always observe the basic rules of safety when working with any conveyor system. To avoid injury and equipment damage, be sure that all controls to the conveyor are locked out and the power source is disconnected at all times during installation.*

## Survey of Conveyor

A visual survey of the conveyor system is recommended. Look for belt contact with return roller hangers, conveyor framing and discharge chute sides.

Check lagging on drive and non-drive pulleys, lagging worn in the center will make the belt unstable and difficult to train.

Check the type of return rollers, if the rubber donut type check to make sure the center rolls are not worn out. If they are worn out the belt will be unstable and difficult to train.

Check for build-up on the return rollers and other pulleys.

Check for spillage that is built-up against the belt in the load zone or around the discharge area.

Look for any obvious structural damage to the conveyor.

Conveyor belt edge damage, may be prevented by ensuring that the conveyor is centralized at the Drive, Tail/Head Pulley and Takeup units.

ASGCO Tru-Trainers are best utilized when placed prior to the conveyor system's terminal points and where misalignment problems occur in intermediate sections of the belt. See Fig. 1.

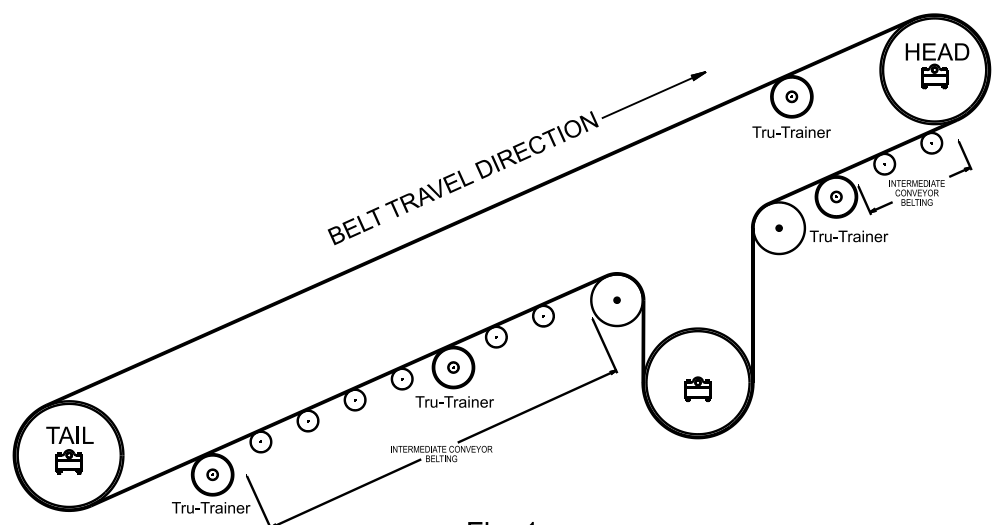

Fig. 1

---

Intermediate conveyor belting is defined as the belting that runs between the terminal pulleys. Loading chutes can also be considered as terminal points.

As the angle of wrap is only 1° to 2° on intermediate conveyor return rollers there is a lot of sideways float. Tru-Trainers can handle these situations with ease. Install a Tru-trainer just prior to the problem areas (area where the belt is most misaligned). If the belt is reversing then put the trainer at the center point of the misalignment.

Conveyor belting at the terminal pulleys has less sideways float as the angle of wrap is between 90° and 220°. In order to correct belt misalignment at terminal points, extra tension might be needed.

# [TTFR] ASGCO TRU-TRAINER™ FLAT RETURN

Check to see if the belt is cupped or if the edges are curled. The edges of a cupped belt will contact the ends of the existing return rollers and is evidenced by shiny ends and dirty or rusty center portion of the existing return rollers. The edges of a curled belt usually do not contact the return rolls and many times is evidenced by the center of the return rolls being shiny and the end of the return rolls being dirty or rusty looking.

It is very important to install the Tru-Trainer so that the edges of the belt contact the tapered end portion of the Tru-Trainer roll. The Tru-Trainer should be on the bottom side of the belt for a cupped belt and on the top side of the belt for a curled belt.

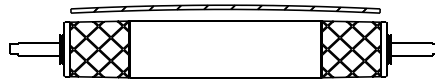

Cupped Belt



Cupped Belt Edge

Generally if the trainer is installed so that the edges contact the belt as shown, then the tension on the trainer can be adjusted to get good contact on the trainer in both the actuation area and the traction area as shown below

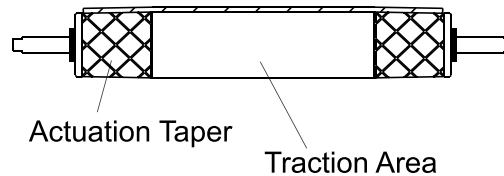

Tru-Trainers should be installed prior to terminal points, at a distance of 3 to 5 belt widths (ie for a 24" belt, the Tru-Trainer should be installed between 6' and 10' before the pulley.)

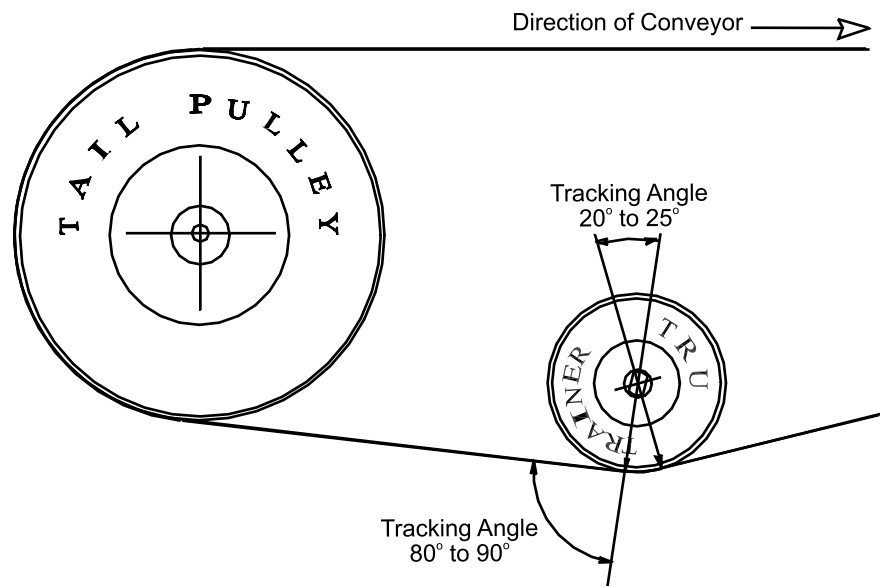
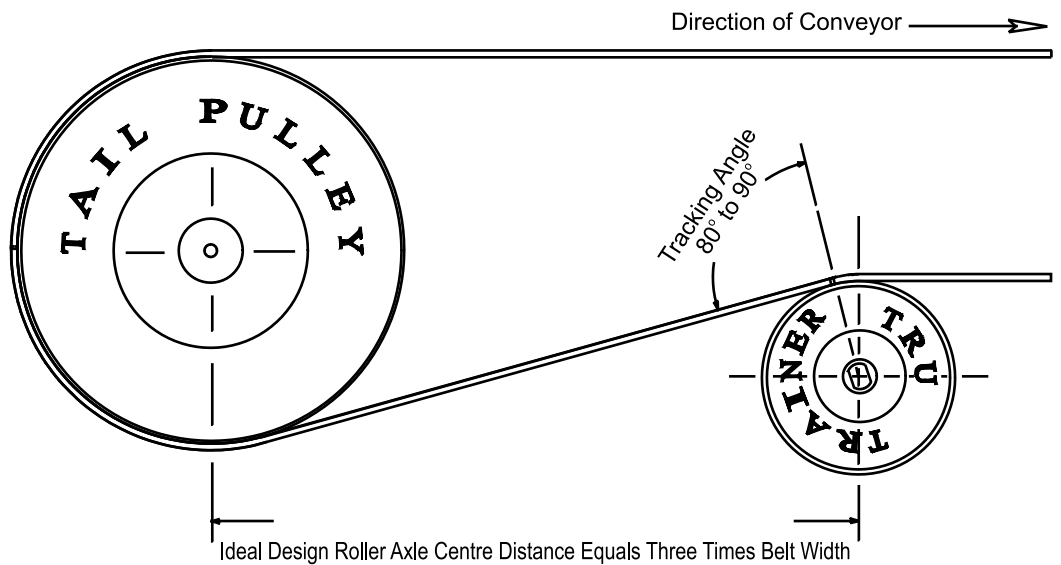

Internal tracking of conveyor belts with the Tru-Trainer, occurs when difficulty is experienced, generally as detailed below.

Limitations as to space available for the normal Tru-Trainer installation.

The return side of the conveyor is extremely dirty and difficult to clean.

Where the tail or head is found to be very small in diameter. For example, food and package handling applications have typically 2 1/2" to 6" diameter tail and head pulleys.

Where buckets, cleats, or sidewalls have been attached to the carrying side of the belt.

It is essential, for correct operation, that sufficient conveyor belt tension is evenly distributed across the trainer's entire working surface.

The vertical pivot axle, within the Tru-Trainer, must be positioned 80° to 90° leaning in the direction of belt travel. The vertical axle is in the same plane as the shaft end flats. When installing on a reversing belt the vertical pivot must be 90° to the belt at the mid point of contact.

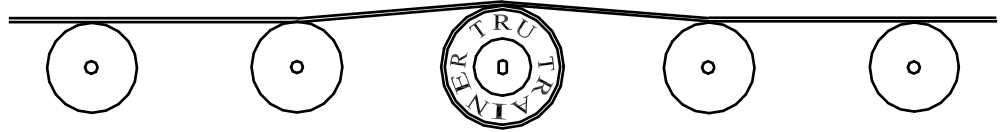

Standard rollers are generally 5" and 6" diameter. Tru-Trainers are manufactured to 6 11/16" diameter, this assists in increasing the belt tension and roller traction.

The Flat Return Tru-Trainer will fit both Belt Width +9 and Belt Width +15 systems when configured as shown below.

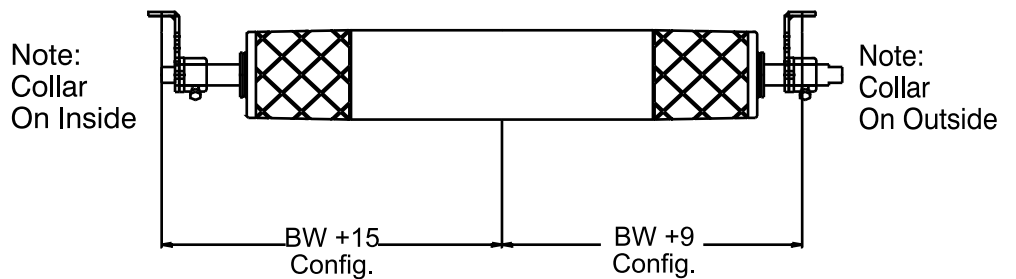

There should be enough tension on the Tru-Trainer so that it is difficult to pivot the trainer about its axis by hand before start-up of the conveyor.

There are several means of increasing tension on the trainer:

1. Raise the roller in the drop bracket.

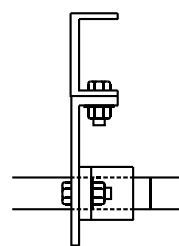

Normal Installation

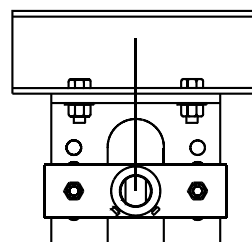

Moving mounting plate up or down to change tension of tracker on belt

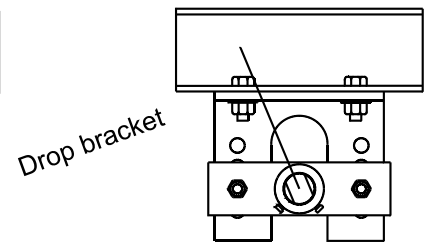

To change tracking angle rotate pivot axle as shown above

2. Remove one or more return rollers either before and/or after the Tru-Trainer to increase the belt weight on the trainer.

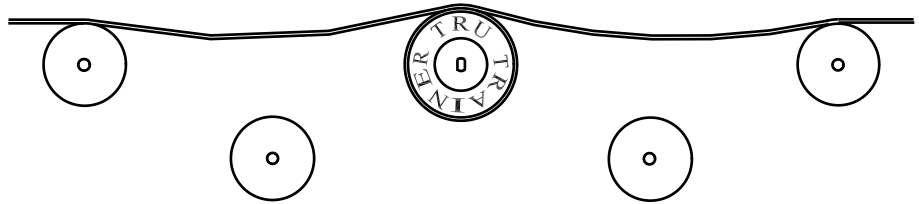

3. Add a pressure roller before the Tru-Trainer to increase tension and wrap angle on the trainer. Adjusting the inwrap angle may require adjustment of the tracking angle, the vertical axle within the Tru-Trainer.

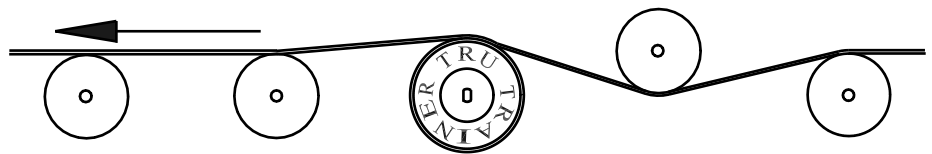

Insure that the rollers prior to the Tru-Trainer are aligned and running true.

Remove any other tracking devices or inverters, which are in front of or behind the Tru-Trainer for a distance of at least 100'.

In general, A Tru-Trainer is effective for 150' to 200' on intermediate belting.

Never install a Tru-Trainer Flat Return trainer on a system, if the belt is wider than the trainer design width. 1" to 2" of trainer must protrude on either end of the trainer to ensure proper operation.

In general increased angles of wrap will improve traction, resulting in improved performance. Increased traction is only needed if the Tru-Trainer is not working correctly.

# (TTDR) ASGCO TRU-TRAINER™ DUAL RETURN

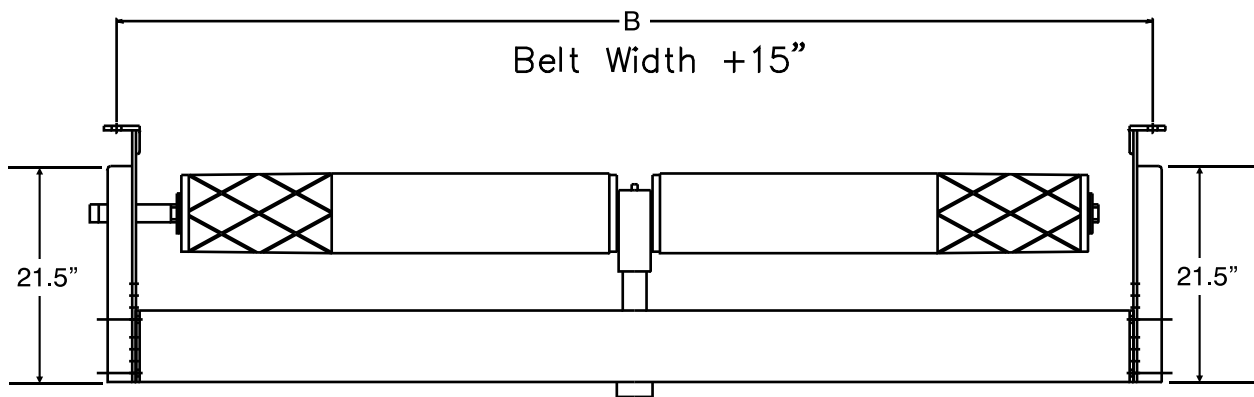
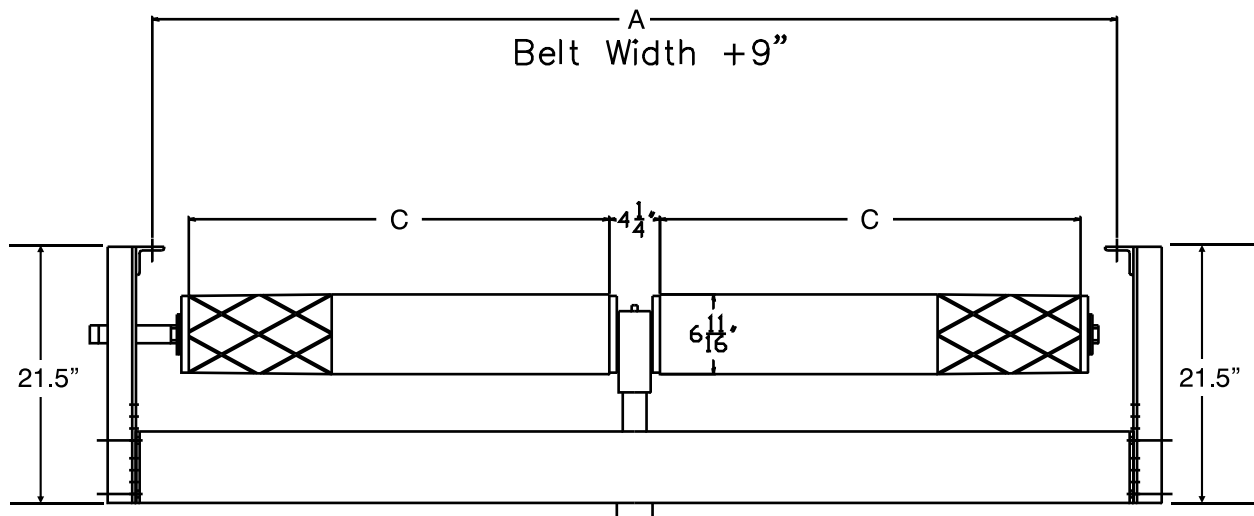

Belt Width	Part Number	A	B	C
60	ASG-TTDR-150	69	75	29
72	ASG-TTDR-180	81	87	15
84	ASG-TTDR-210	93	99	41
96	ASG-TTDR-240	105	111	47

After identifying the problem area, prepare to install TTDR at three to five times the width of the belt before the problem area.

**WARNING: Do not invert the Dual Return (The T-piece is not secured to the Base and will drop out of the base if inverted)**

Remove the existing idler & brackets or V-Return frame.

To ensure ease of access to the tracking adjustment pin (TAP) from the catwalk once installed, ensure that the TTDR is positioned with the TAP facing the catwalk before proceeding.

Set the distance between the inside of the plates to the recommended distance "C" as per the table below. Increase the distance if you need more tracking. Because the Dual Return bi-directional, it doesn't matter which way it is installed.

	BELT WIDTH	C (For ideal included angle = 4,5°)
TTDR 135	54"	3 1/2"
TTDR 150	60"	3 3/4"
TTDR 165	66"	4"
TTDR 180	72"	4 1/2"
TTDR 200	78"	4 3/4"
TTDR 210	84"	5"
TTDR 230	90"	5 1/4"
TTDR 240	96"	5 3/4"

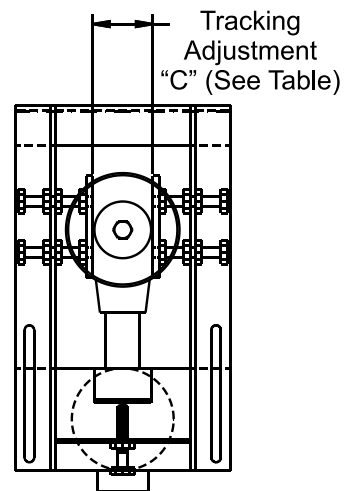

Fig. 7

---

Use sling and chain hoists to lift the TTDR into position under the conveyor belt.

Bolt TTDR Bracket onto structure. Before tightening ensure both brackets are knocked fully forwards or backwards to ensure the TTDR brackets are perpendicular to the structure and lined up exactly opposite each other. Once completed tighten all bolts.

Ensure that sufficient conveyor belt tension is evenly distributed across the tracker's entire working surface.

Move the Dual Return with the tracking adjustment pin to check the tension. If tension is correct, it should be difficult to move the pin backwards or forwards.

To create more tension, move up using pusher bolt each of the brackets to create sufficient tension.

Start the conveyor belt to test the Dual Return.

Check that the Dual Return tracks the belt from both directions.

Manually de-track the belt by moving the tracking adjustment pin in one direction. When you release the pin, The Dual Return should automatically center the belt. Repeat this test by moving the tracking adjustment pin the opposite direction.

If the Dual Return doesn't center the belt, or responds too slowly, increase the tension.

1. When the rubber on the individual rolls wear outs. Remove the individual rolls from the TTDR T-Piece and replace with a new set.

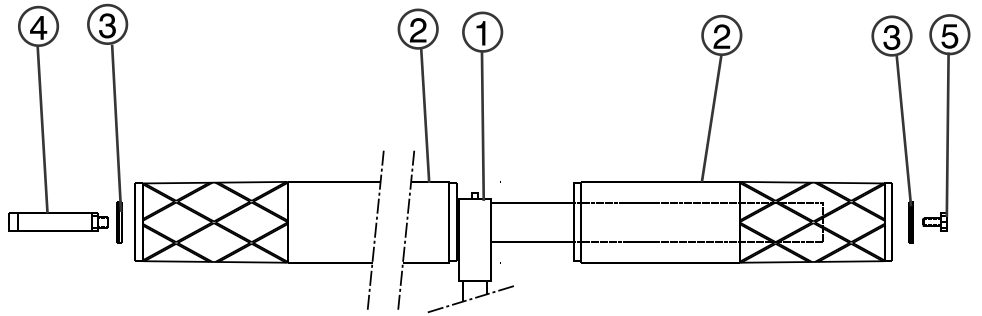

Fig. 8

**LIST OF COMPONENTS:**

- 1. Center pivot
- 2. Roller
- 3. End cap
- 4. M20 bolt
- 5. Tracking Adjustment

2. Loosen M20 bolt [4] and End cap [3] then slide the roll [2] off the center pivot shaft [1].
3. Loosen TAP [5] and End cap [3] then slide the roll off center pivot shaft [1].
4. Apply a thin layer of grease to the shaft before proceeding with next step. Recommended grease: SHELL ALVANIA EP(LF)
5. Slide new roller onto center pivot shaft.
6. When pressing the end caps back onto the shaft, align the hole in the end cap with the spring pin protruding from the shaft.
7. Then screw the M20 Bolt and Tracking Adjustment Pin (TAP) into the shaft and tighten.

It is essential that the Tru-Trainer Trough tracker system be installed with the **conveyor belt traveling in the correct direction**. The wing rollers must touch the oncoming conveyor belt first.

---

# (TTT) ASGCO TRU-TRAINER™ TROUGH TRAINER

**DETERMINE WHICH  
TYPE YOU HAVE:**

## **EDGE CONTACT DESIGN**



(See Page 13)

## **LOAD CARRYING DESIGN**

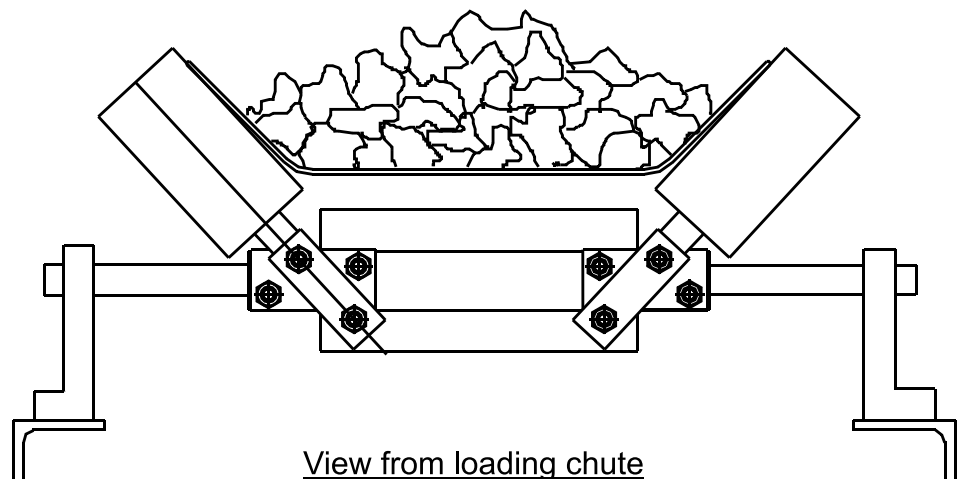

(See Page 15)

---

# (TTT) ASGCO TRU-TRAINER™ TROUGH TRAINER

## EDGE CONTACT DESIGN

The Tru-Trainer Trough tracker is installed prior to where problems occur on the load carrying side of the belt.

The Tru-Trainer Wing Rollers are fixed at 70°. They intercept the belt drift and activate the steering mechanism, in order that the Tru-Trainer will correct and centralize the belt path.

Next, slide the wing rollers into the brackets ensuring that the shaft is flush with the bottom of the bracket tube and tighten the locking bolts.

The Tru-Trainer Trough tracker system is compatible with all 15° to 45° troughed rollers.

The Tru-Trainer Trough tracker, in line with Tru-Tracker principles, is installed slightly higher than normal existing rollers (1/2" to 3/4") to insure good traction for the tracking of the conveyor belt.

It is recommended that the Tru-Trainer Wing Rollers be set to miss the edge of the existing troughed conveyor belt edge by between 3/16" minimum and 3/8" maximum on either side.



Fig. 9

---

The Tru-Trainer Trough tracker, normally, replaces an existing standard trough roller set.

Where existing conveyor belts are very flexible, the Tru-Trainer Trough tracker should be installed between existing trough rollers.

The Tru-Trainer Trough tracker, in line with Tru-Tracker principles, is installed slightly higher than normal existing rollers (1/2" to 3/4") to insure good traction for the tracking of the conveyor belt.

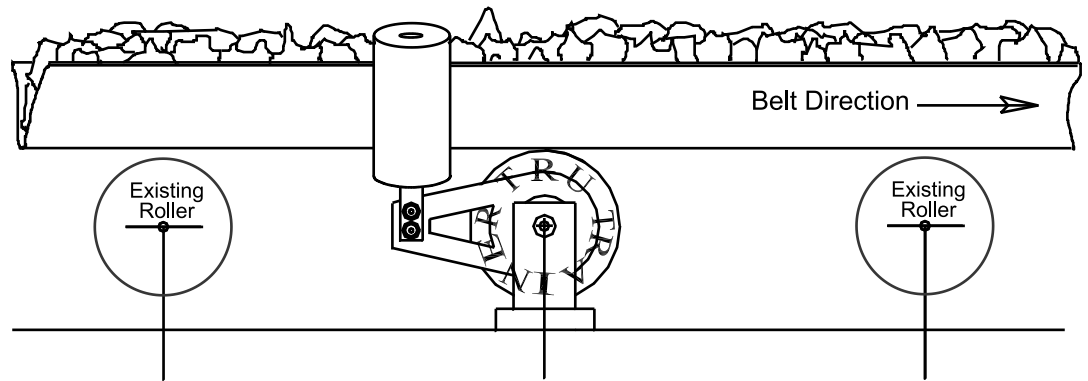

Fig. 10

# (TTT) ASGCO TRU-TRAINER™ TROUGH TRAINER

## LOAD CARRYING DESIGN

1. After identifying the problem area on the load-carrying side of the belt, looking particularly for the high spot, prepare to install the Tru-Trainer Trough Tracker at or just before the problem area, ensuring that it is installed before transitional idlers and after loading chutes.
2. Remove a standard troughing frame at the problem area. Remove the steel roll from the Trough Tracker.
3. Bolt L-shaped bracket on to structure. Before tightening, ensure both brackets are knocked fully forwards or backward to ensure the L-shaped brackets are perpendicular to the structure and lined up exactly opposite each other. Once completed, tighten all bolts.
4. Slide the Rectangular-shaped bracket on to either end of the shaft, with fixing bolts facing upwards.
5. Lift up Tru-Trainer Trough and bolt the Rectangular-shaped bracket on to the L-shaped bracket, ensuring that the corresponding set of holes are used.
6. Very important: Ensure the Tru-Trainer Trough is installed in the correct direction. The wing rolls must touch the oncoming conveyor belt first. (See Fig. 10)
7. Set the space between the mounting bracket and Tru-Trainer evenly, to ensure the Tru-Trainer will be center on the structure.

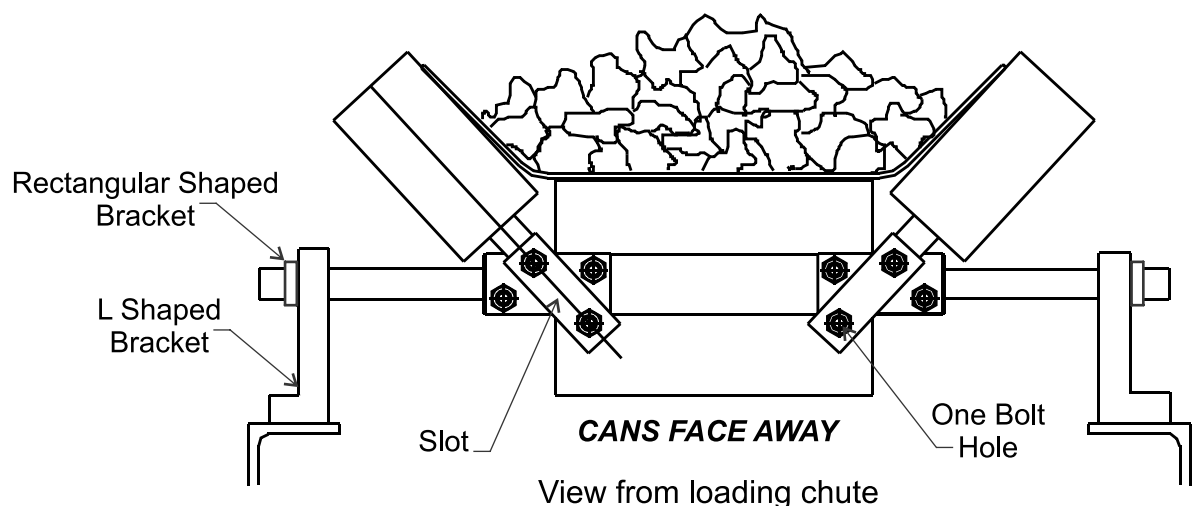

Fig. 11

- 
8. Before you tighten the Tru-Trainer Trough height adjustment bolts to the L-shaped brackets, ensure that it has got sufficient tension by pushing it backwards and forwards. It should be quite stiff and tight. If it moves easily backwards and forwards, there is not enough tension, usually 1/4-3/4" higher than rolls on each side
  9. Loosen the height adjustment bolts and move it upward one hole on the L-shaped bracket. Recheck tension, if tension is insufficient move up another hole until sufficient tension is achieved. Once you're satisfied with amount of tension, tighten Tru-Trainer Trough height adjustment bolts.
  10. Install the Tru-Trainer Trough slightly higher than the normal existing idlers to ensure good traction.
  11. Loosen the all the bolts on the sliding bracket on the Tru-Trainer Trough and then insert the steel rolls into the sliding bracket ensuring the end of the shaft is flush with the bottom of the bush. Allowing the rolls to hang freely.
  12. Push the sliding bracket inwards until the steel rolls begins to touch the underneath side section of the belt, then lift the steel rolls upwards & inwards so that the only the top ¼ section of the steel roll is touching the belt. (Ensuring that the bottom section of the belt remains in contact with the rubberised drum)
  13. Check that the angle of the steel rolls are similar and that sliding brackets is equidistant about the center point of the flat bar.
  14. Finally, tighten the bolts
  15. Manual test before start up. **Belt NOT running:**
    - *Move the steel rolls backwards and forwards to ensure that the Top ¼ section of the steel rolls remain in contact with the belt throughout the motion. If not, adjust the sliding bracket accordingly until the correct contact is achieved.*
  16. Installation is now complete, start the conveyor belt to test the Tru-Trainer Trough Tracker.

**CAUTION DANGER! TAKE CARE.**

17. Test that the Tru-Trainer Trough tracks the belt from both sides. Using a blunt object, manually de-track the belt by pushing the outside of the Tru-Trainer Trough fully in one direction. When you release it, the Tru-Trainer Trough should automatically center the belt. Repeat this test by pushing the outside of the Tru-Trainer Trough fully in the opposite direction. If installed correctly, it should centralize the belt from both sides.

18. If sufficient belt alignment is not achieved, increase the Tension or adjust the sliding bracket & angle of the steel rolls.
19. If the problem still persists, knock the existing standard trough frames perpendicular to the structure before and after the Tru-Trainer Trough.
20. Remove any other tracking devices in front of or behind the Tru-Trainer Trough, as they will reduce or interfere with the performance of the Tru-Trainer.

## TESTING A TRU-TRAINER ROLLER INSTALLATION

Manually force, by the insertion of a steel tool into the Tru-Trainer shaft/inner tube clearance at one end of the Tru-Trainer, to steer the conveyor belt off track. See Illustrations below.

After removing the tool, the Tru-Trainer should automatically centralize the belt, and the trainer should return to the neutral central position.

The Tru-Trainer must be activated in both directions, using the tool, thus ensuring centralization of the belt from either side of the installation.

If the Tru-Trainer remains in either of the positions shown (A or C), then the conveyor belt tension on the Tru-Trainer is probably not sufficient to create satisfactory traction. See Pages 5 and 6.

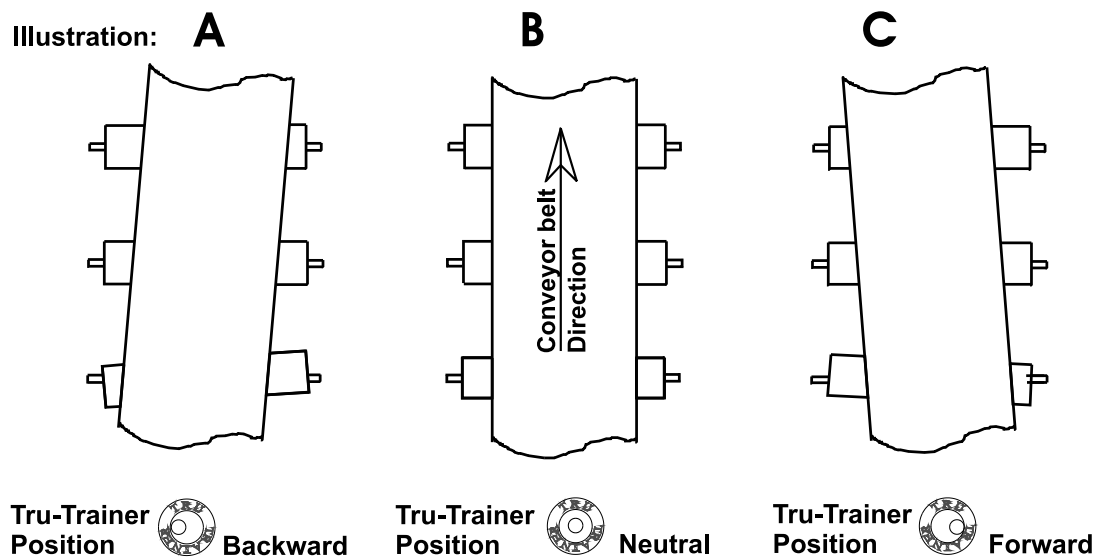

Fig. 12

---

## TROUBLE SHOOTING SECTION

1. The Tru-Trainer actuates but the belt does not move into alignment.

There are several situations where this will occur:

First, the edges of a slightly cupped belt are contacting the edges of the Trainer causing it to actuate, but there isn't enough contact with the center of the Trainer to develop the tracking traction necessary to train the belt.

Second, the Trainer has good solid tracking contact and the belt refuses to move into proper alignment. This condition is caused by a misalignment somewhere in the system that simply overpowers the Trainer.

Check to see if all other rollers are square.

Check and remove all other belt alignment devices.

Check the terminal pulleys for alignment.

Check the lagging on terminal pulleys, worn lagging can cause misalignment.

Check for build-up of material on pulleys.

Third, a very small number of trainers seem to perform better if the shaft is rotated 180° in the mounting bracket. This condition is caused by a slight misalignment of the internal pivot from the perpendicular to the centreline of the shaft.

2. The Tru-Trainer does not actuate but will train the belt when manually actuated.

The belt has a slight cup or curl, which causes the edge of the belt to curve away from the ends of the Trainer. This condition caused the actuation tapers to lose traction with the edges of the belt and lose actuation traction. The best way to solve this problem is to move the trainer to the other side of the belt thereby putting the edges of the belt in direct contact with the trainer.

3. A troughing Tru-Trainer will train the belt but only for a short distance. The load on a belt will always try to seek the lowest point due to gravity. If the load is off center the trainer will move the belt locally but the belt will move off center shortly after the trainer.

The solution is to center the load on the belt. Use a Return Tru-Trainer on the return side to align the belt with the tail pulley and the load zone and install deflectors in the chute to center the load on the belt.

A troughing Tru-Trainer installed just before the head or discharge pulley will usually protect the belt by keeping it from contacting the head frame.