



REQUEST FOR QUOTE FORM

Complete and Fax or E-mail

Customer: _____ Contact: _____
 Plant Name: _____ Title: _____
 Address: _____ Phone: _____
 City: _____ Fax: _____
 State: _____ Zip: _____ Country: _____ Email: _____

MATERIALS HANDLED:

Material _____ Required Capacity: _____
 Density: _____ Moisture Content: _____
 Lump Size (Min/Max) _____ Belt Speed _____

* Required Data

STUB IDLERS

(85% of recess should be supported)

COVERS: _____ Rubber
 _____ Urethane
 _____ Plain Steel

CUSTOM DESIGN Style - Drop / Rise

QUANTITY _____

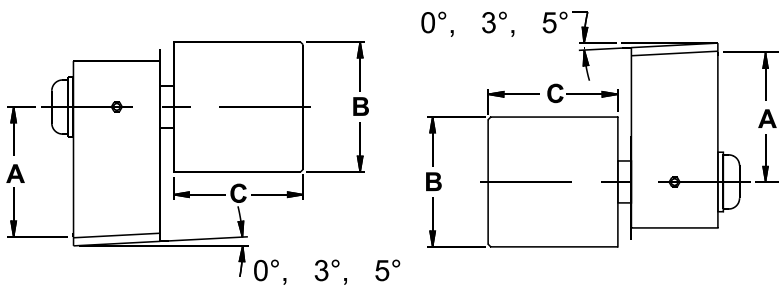

*A = _____
 *B = _____
 *C = _____
 *D = _____

FLEX MOUNT DESIGN

*A = _____
 *B = _____
 *C = _____

SERIES - B, C, E

SERIES - C, D, E

DROP BRACKET (Circle One) **RISE BRACKET**

BELT BEATERS

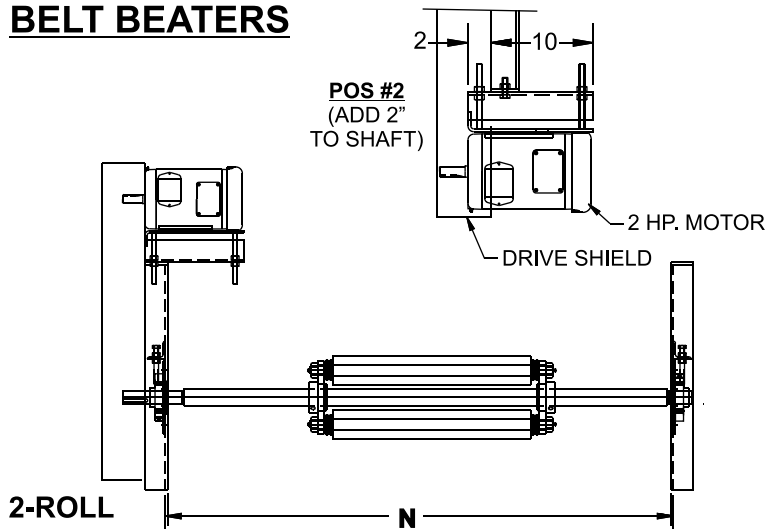

* BELT WIDTH _____
 BELT TYPE - FLEXIBLE SIDEWALL ()
 TROUGHING ()
 * SIZE - 2-ROLL (12"-42" Width)
 4-ROLL (42" - 72" Width)
 * MOTOR LOCATION - POS1 () POS2 ()
 * N = _____ OUT TO OUT OF FRAME
 BEATER ONLY () SHAFT LENGTH _____
 SPEC. MATERIALS: (S.S.) _____
 (OTHER) _____

DAMPENING ROLL ASSEMBLY

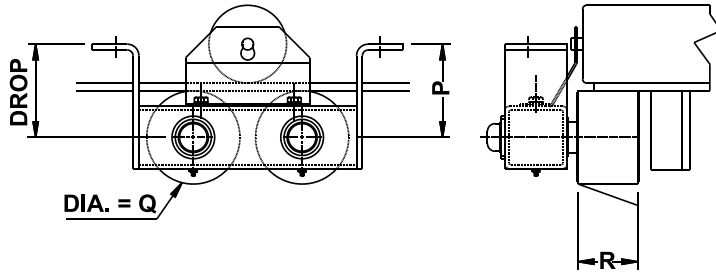

BELT WIDTH _____

*P = _____ DROP

*Q = _____ DIA.

*R = _____ FACE

GUIDE IDLERS

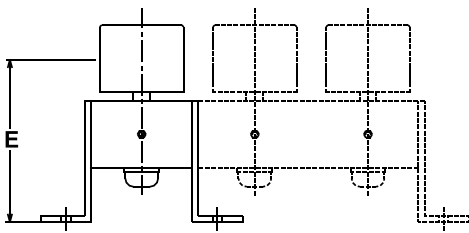

CARRY SIDE

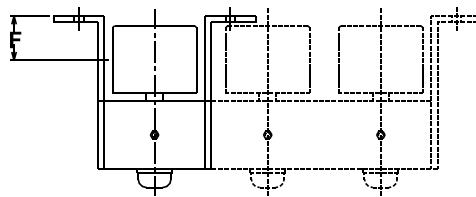

RETURN SIDE

TYPE/QUALITY

CARRY:

SINGLE _____ DUAL _____

TRIPLE _____ E = _____

RETURN:

SINGLE _____ DUAL _____

TRIPLE _____ F = _____

LAGGING (Specify): _____

CANTI-WHEELS

(4 X Sidewall Height)

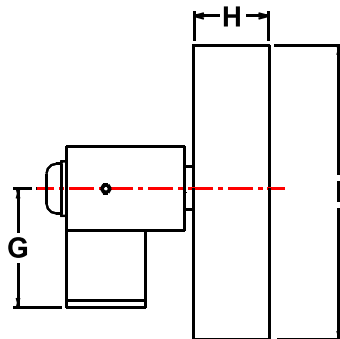

* G = _____ RISE

* H = _____ FACE

* I = _____ DIA.

Lagged _____

Type _____

Thickness _____

DEFLECTOR WHEELS

(4 X Sidewall Height)

OPTION - PILLOW BLOCKS:

SIZE _____

BRAND _____

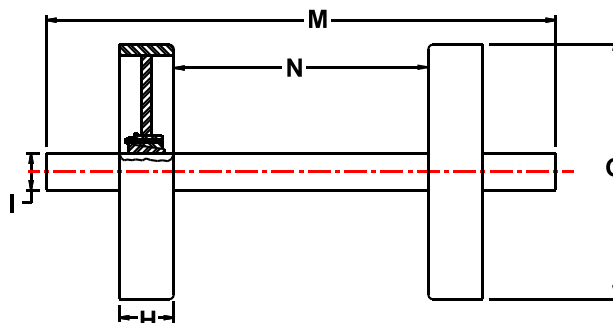

H = 85% of recess

* G = _____ RISE

* H = _____ FACE

* I = _____ DIA.

* M = _____ OAL

* N = _____

* Lagged _____

Type _____

Thickness _____