



# MINI-SKALPER<sup>®</sup>

*with Force-1<sup>®</sup>*

## INSTALLATION, OPERATION & MAINTENANCE INSTRUCTIONS

For All Mini-Skalper Blade Types

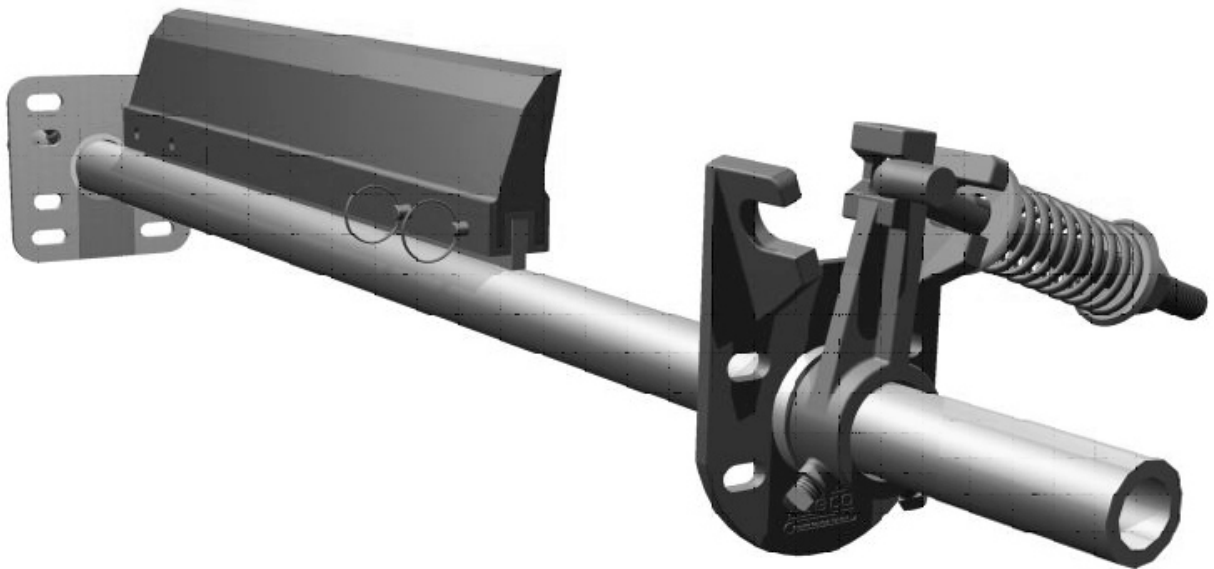

*Force-1*

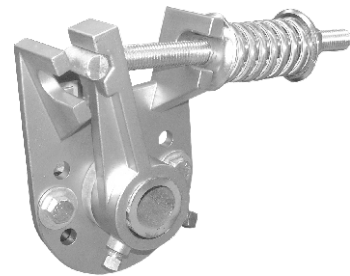

Check us out at  
[www.asgco.com](http://www.asgco.com)

Customer Service  
**800-344-4000**



24 Hour Emergency  
Service and Parts  
610-821-0210



ASGCO Mfg., Inc.  
301 Gordon Street  
Allentown, PA 18102  
610-821-0216  
FAX 610-778-8991

## Important Safety Notice

Always observe the basic rules of safety when working with any conveyor system. To avoid injury and equipment damage, be sure that all controls to the conveyor are locked out and the power source is disconnected at all times during installation.

## Overall View

If mounting structure is not available, additional steel may have to be added. *Note: Excess mounting tube may be trimmed after installation. Also note required lubrication of components.*

## Components Diagram

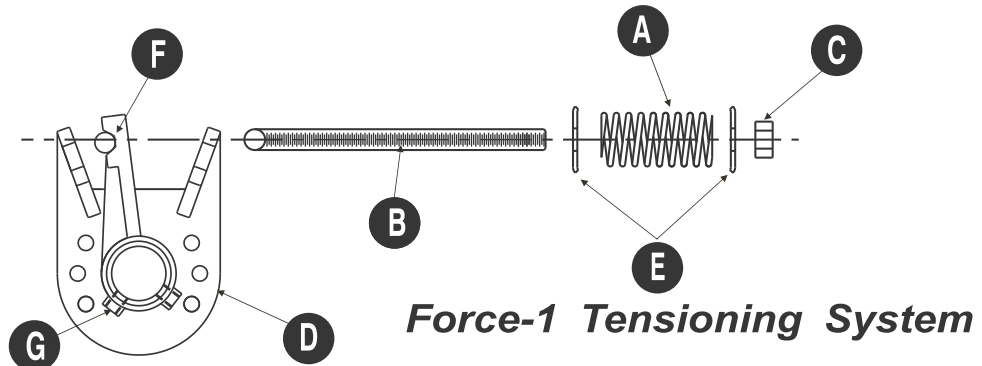

**Force-1 Tensioning System**

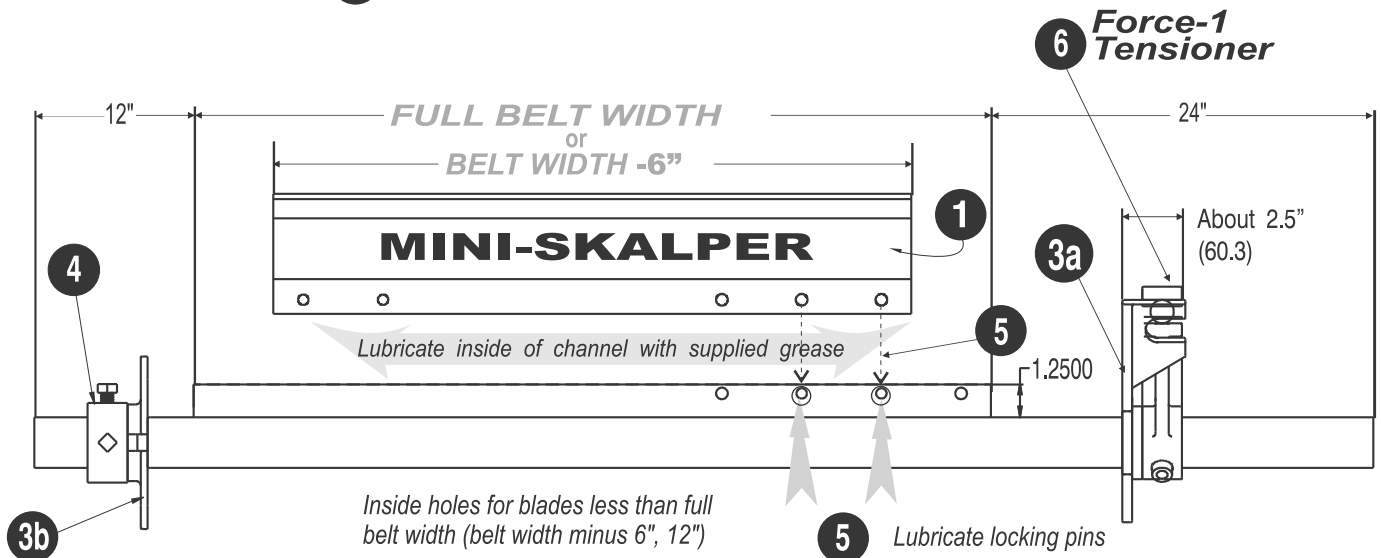

- 1 Mini-Skalper Clean Blade
- 2 Mounting Tube
- 3a Tension Side Mounting Bracket
- 3b Opposite Side Mounting Bracket
- 4 Locking Collar with Set Screws
- 5 Locking Pins (2)

- 6 Force-1 Tensioner
- A Spring
- B Tensioning Bolt
- C Tensioner Nut
- D Tensioner Mounting Bracket
- E Locators
- F Power Adjustment Arm
- G Power Adj. Set Screws

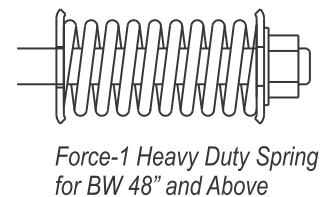

See last page for Part Number and Ordering Information

The Force-1 Mini-Skalper is a Primary Cleaner designed to be installed on pulleys.

## 1. Determine the Critical "N" Dimension

Determining the "N" dimension, the distance from the belt surface to the mounting tube center, is critical to get the maximum cleaning performance from your system. Make sure mounting tube and tensioner system are clear of obstacles.

<b>"N" Dimension Table</b>	
Pulley Diameter	"N" Dimension
<b>Note the tolerance is <math>\pm 1/4</math>"</b>	
6"	4-5/16"
8"	3-15/16"
10"	3-11/16"
12"	3-7/16"
14"	3-3/16"
16" and up	3-1/16"

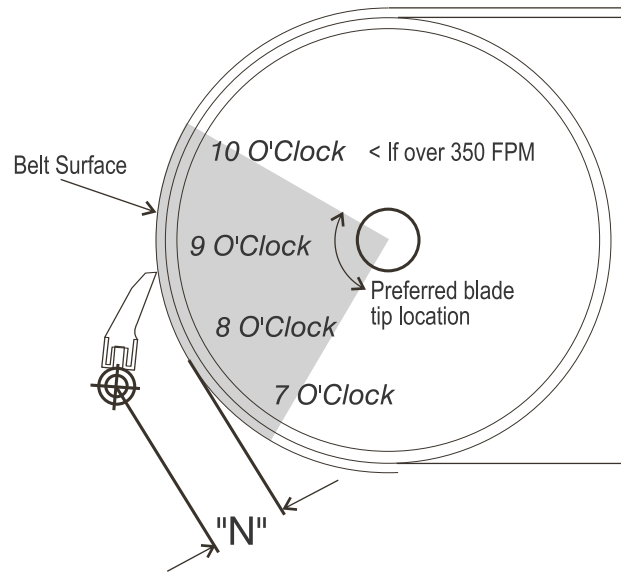
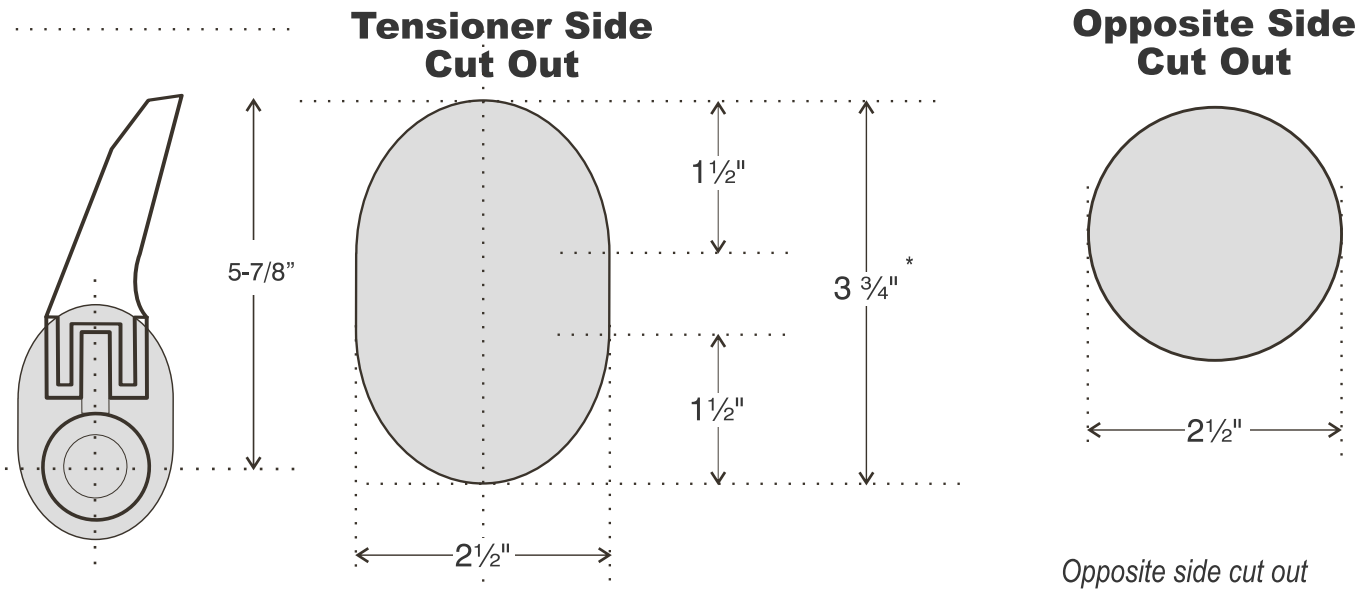

Figure 1: Typical Mounting Position

\*Note:  $\pm 1/4$ " tolerance

## 2. Cut Chute Openings

Determining the desired location of the mounting brackets. The required slot sizes/locations are shown for the tensioner side chute cut outs.



\*Dimension is 6" for BW 72" and greater

Opposite side cut out is a 2 1/2" hole to install mounting tube

### 3. Put Mounting Tube through Cut Outs

Place the mounting tube through the chute cut outs so that the long tube section is on the tensioner side. Place the blade onto the blade holder. Visually check the blade position and contact with the belt/pulley.

### 4. Mount Brackets

Determine the desired location of the mounting brackets. Attach the mounting brackets to the conveyor frame by welding or bolting.

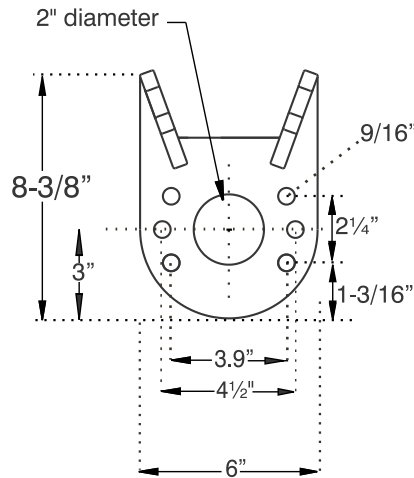

**Tensioner Side**

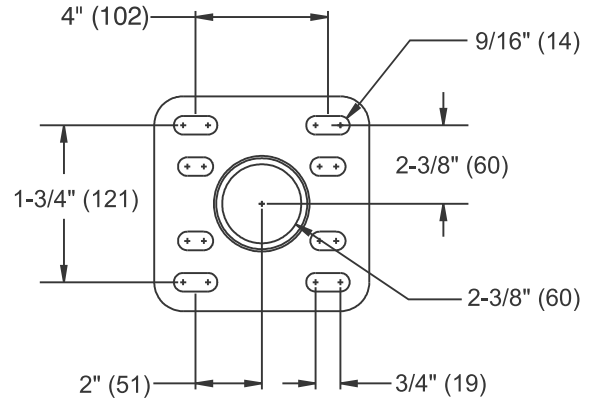

**Opposite Side**

### 5. Select Correct Spring

Depending on the side the tensioner will be used the tensioning bolt and nut assembly will need to be reversed. If the tensioner is to be on your right if you are facing the head pulley then FIG. 1B would be the way the tensioner would look. If you facing the head pulley and you need the tensioner to your left then FIG. 1A would show the correct set-up.

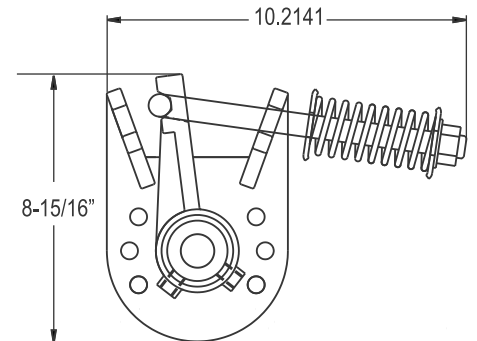
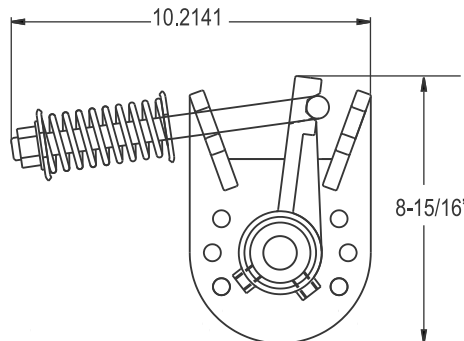

Depending upon the Blade width ordered this will determine the style spring which also shipped: For Blade widths 18"-42" a red spring has been supplied. For units 48"-84" a silver grey spring has been supplied.

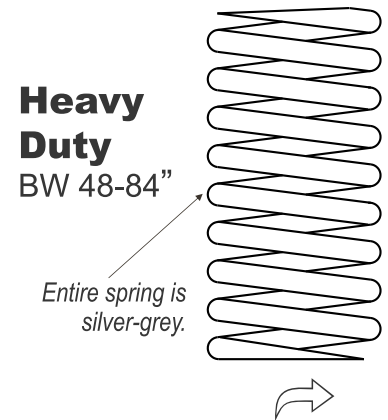
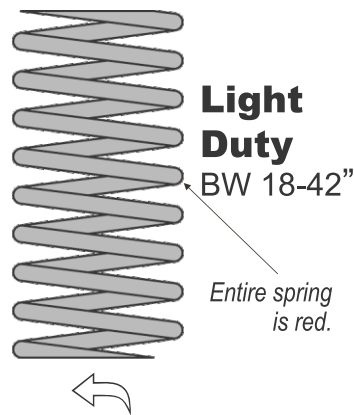

## 6. Assemble Force-1 Tensioner:

Assemble the Force-1 tensioner. Tighten all collar set screws to 70 ft./lbs.

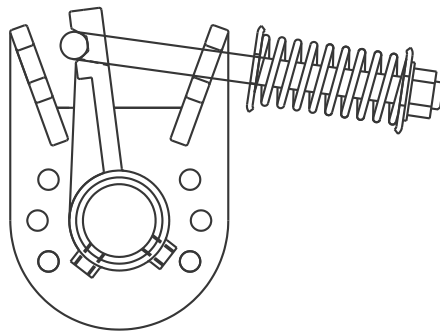

## OPERATION & MAINTENANCE

### Tensioning the Force-1 Tensioner

- 1.) The following chart shows the “d” dimensions for a particular blade width.

	BLADE	“d” DIMENSION
<b>STARTING DIMENSION = 3.6250”</b>		
<b>LIGHT DUTY SPRING (RED)</b>	18	3.125
	24	3.000
	30	2.750
	36	2.625
	42	2.375
<b>HEAVY DUTY SPRING (SILVER)</b>	48	3.375
	54	3.250
	64	3.125
	72	2.875
	84	2.625

- 2.) FIG. 2A shows the direction the Force-1 tensioning nut needs to go to increase tension. FIG. 2B shows where the “d” dimension should be measured from.

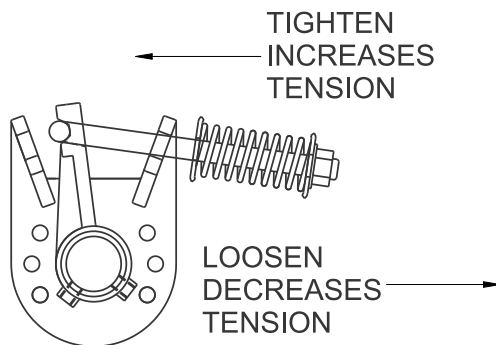

Fig. 2A

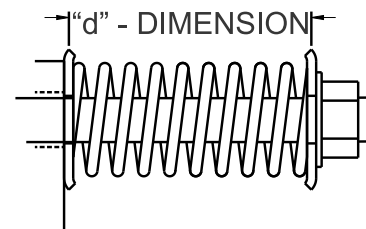

Fig. 2B

- 3.) The starting “d” dimension at roughly 3.625” start to tighten the nut to the “d” which best fits your application. I.E. if you have a 36” belt width than tighten the screw till your “d” dimension is roughly 2.625”. This will produce roughly 1 lb./inch of blade width which is typical of each “d” dimension.

This is an approximate starting point. Loosen nut until less cleaning is observed then tighten slightly. The minimum amount of tension required will maximize blade life.

- 
- 4.)** Frequent inspections the key to proper belt cleaning and easy scraper servicing. Weekly inspections are recommended, but actual service frequency may vary widely depending on various plant operating conditions.
  
  - 5.)** Inspect the belt surfaces and edges for cracks, splits, tears, holes or any other worn or damaged condition occurring on the surfaces or edges of the belt itself. If necessary make repairs to the belt. Wash the entire cleaner regularly to prevent excessive build-up. Check the tightness of all fasteners.
  
  - 6.)** Inspect for proper operation. Adjust tension as required.
  
  - 7.)** Replace the Skalper scraper blade as required. Use only ASGCO Manufacturing approved replacement scraper blades.

## TROUBLE SHOOTING

<b>PROBLEM</b>	<b>SOLUTION</b>
<i>Excess vibration of the scraper.</i>	<p>Make certain all bolts are tight and the pin is securely engaged on the tensioner.</p> <p>Ensure the cleaners N-dimension is proper (See Table and Figure 1).</p>
<i>Excess carryback.</i>	<p>Check for excess build-up on the scraper.</p> <p>Check for proper Scraper tension. Put additional tension on cleaner.</p> <p>Check for non-uniform scraper wear.</p> <p>Check N-dimension.</p> <p>Clean the back-side of the belt cleaner.</p>
<i>Check for wear on the cleaning tips.</i>	<p>Check thickness of carryback. If the cleaner must remove more than about 1/8" of material then an additional cleaner may be needed.</p>
<i>Frozen material on scraper.</i>	<p>Place heaters near scraper to melt frozen material. (Use caution not to burn belt or cleaner)</p>
<i>Blade wearing in center</i>	<p>BW-6", BW-12 (Put a narrower blade on the system to concentrate cleaning in the center of the flow of the material.)</p>
<i>Blade wearing more on one side</i>	<p>Check N-dimension.</p>

## Information

Key	Description	Part Number
1	Mini-Skalper Blade Replacement	ASG-SK4M-[BW]-A [X]=Blade Type, [BW]=Blade Width
2	Mounting Tube	M-ASG-SKMT-(BW)-AM (BW) Belt Width
3	Mounting Bracket Tension Side	ASG-ECONO-T-MB-TS
3a	Mounting Bracket Opposite Side	ASG-ROT-MB
4	Locking Collar with Set Screws	ASG-SKMT-LC
5	Locking Pins (2)	M-ASG-SKMT-CL
6	Force-1 Tensioner	M-ASG-DURA-T-KT
6a	Spring	ASG-ECONO-T-[XXXX] = 1242 OR 4896
6b	Tensioner Bolt	ASG-ECONO-T-AB-3/4X10-1/2
6c	Tensioner Bolt Nylon Nut	ASG-NUT-3/4G5
6d	Tensioning Mounting Bracket	ASG-ECONO-T-SL
6e	Locator	ASG-ECONO-T-SL
6f	Power Adjustment Arm	ASG-ECONO-T-PAA
6g	Locking Collar Set Screw	AS-SSH-8X1.0-NCG8

*Call your ASGCO Distributor for any questions or replacement parts*