

8 7 6 5 4 3 2 1

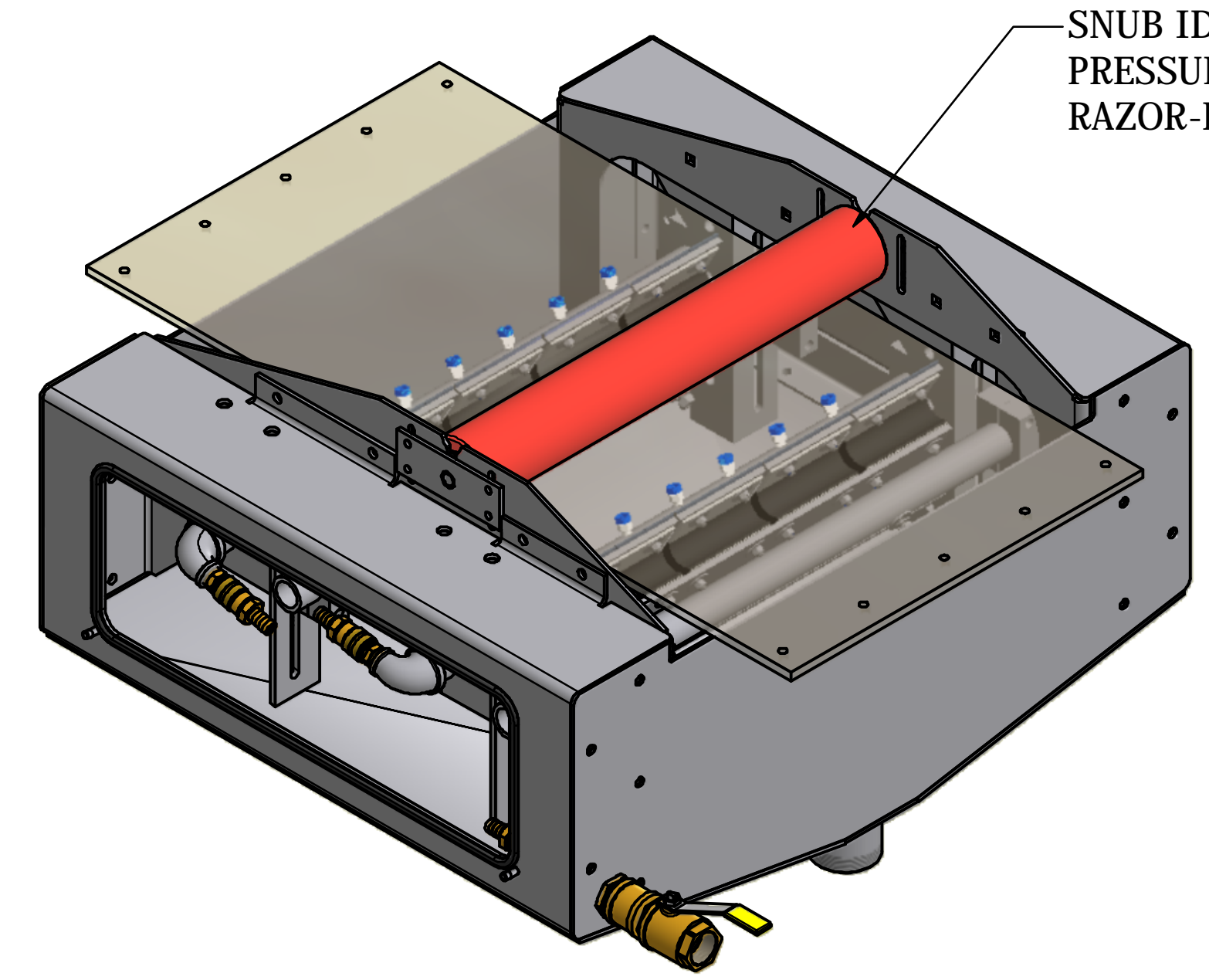

SNUB IDLER PROVIDES EQUAL PRESSURE ON BOTH RAZOR-BACK CLEANERS

DUAL SET OF SPRAY BARS AND RAZOR-BACK SECONDARY CLEANERS

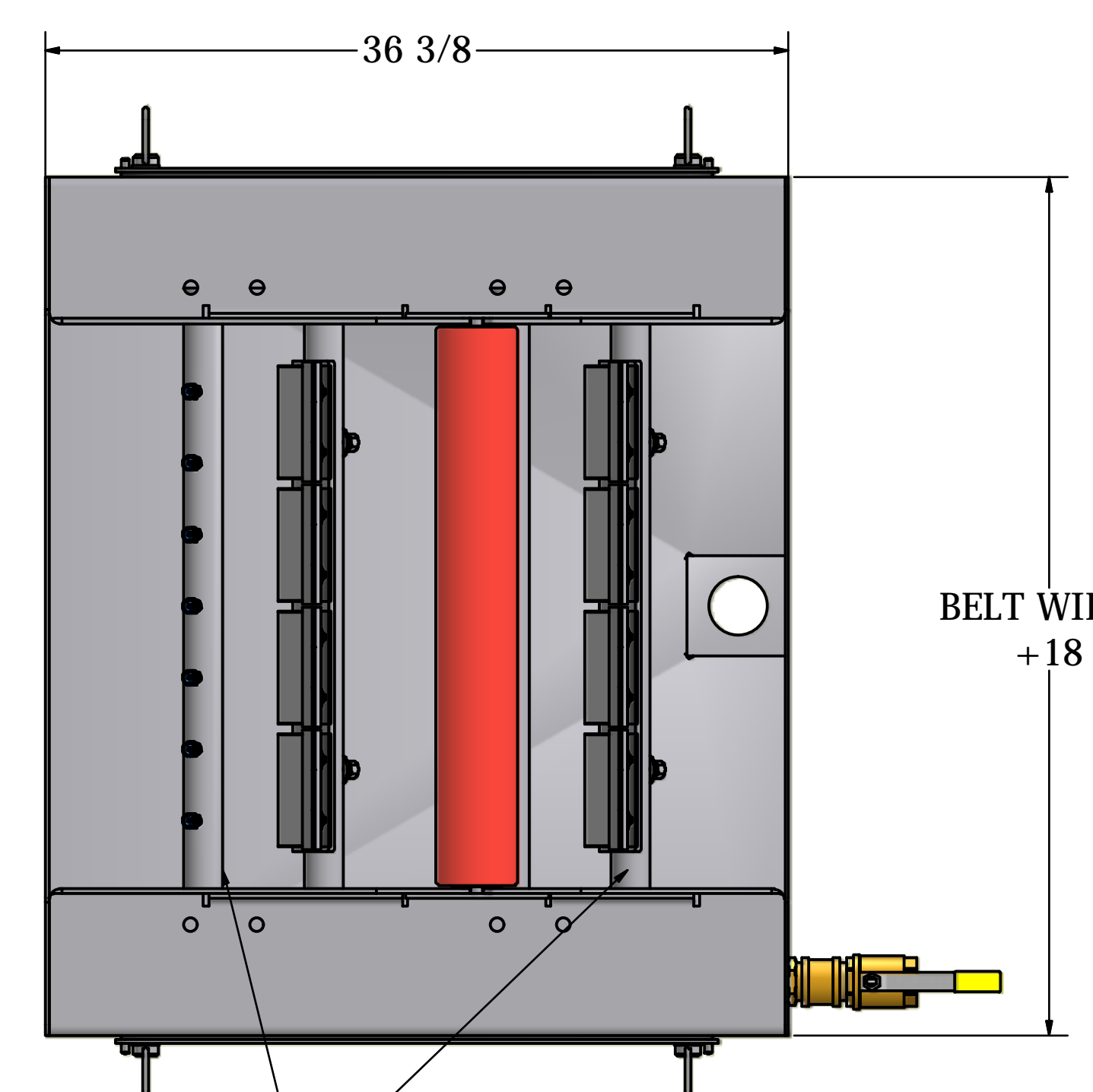
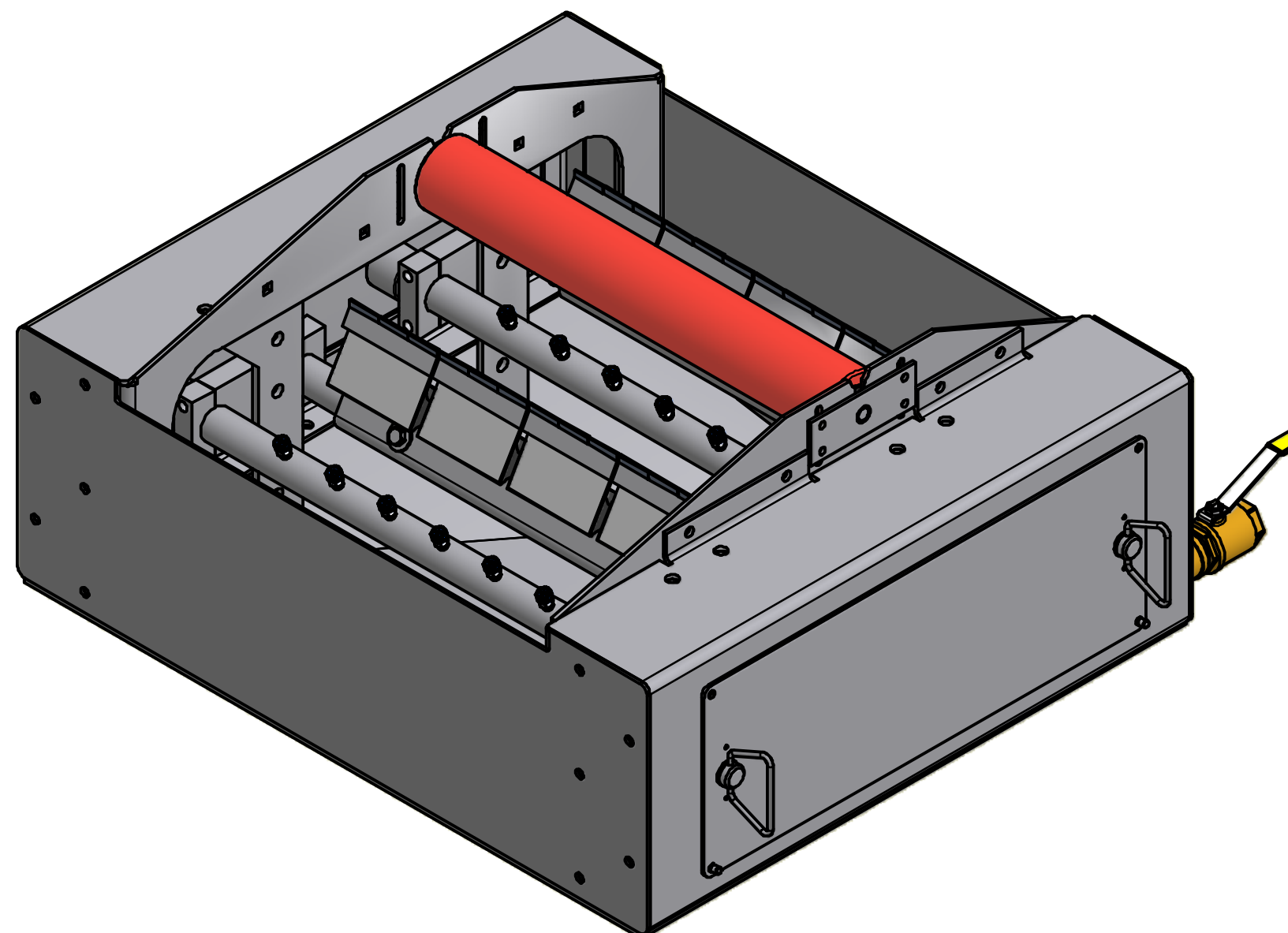
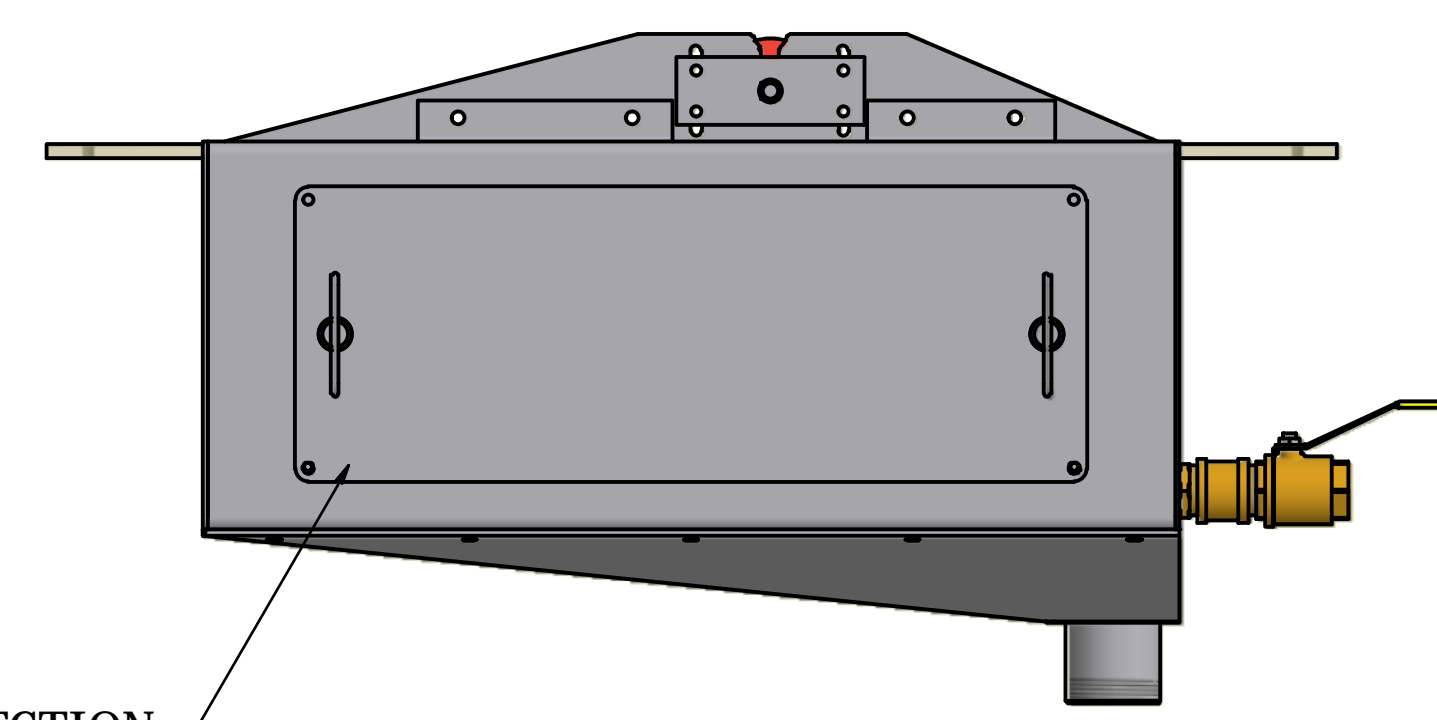
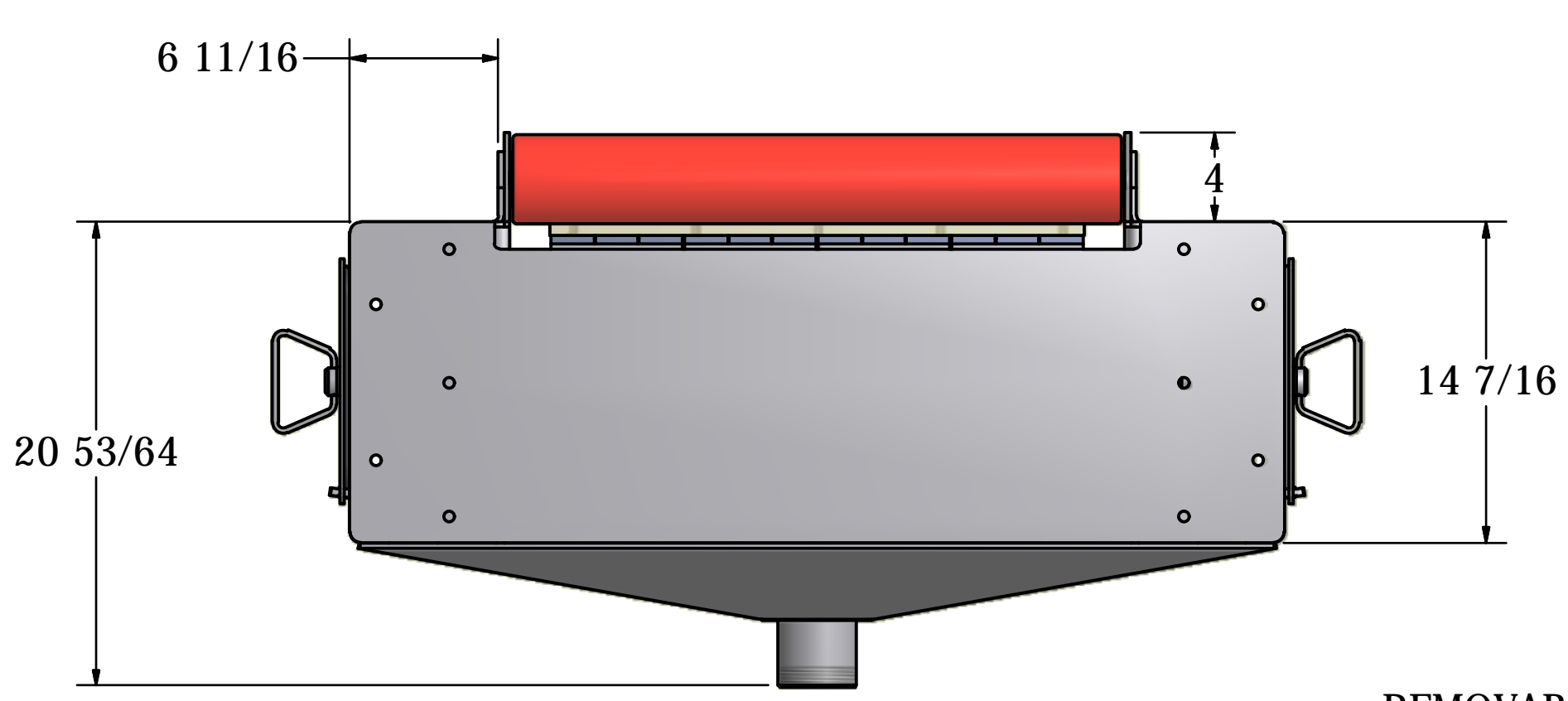

REMOVABLE INSPECTION AND SERVICE DOOR (DOOR ON EACH SIDE)

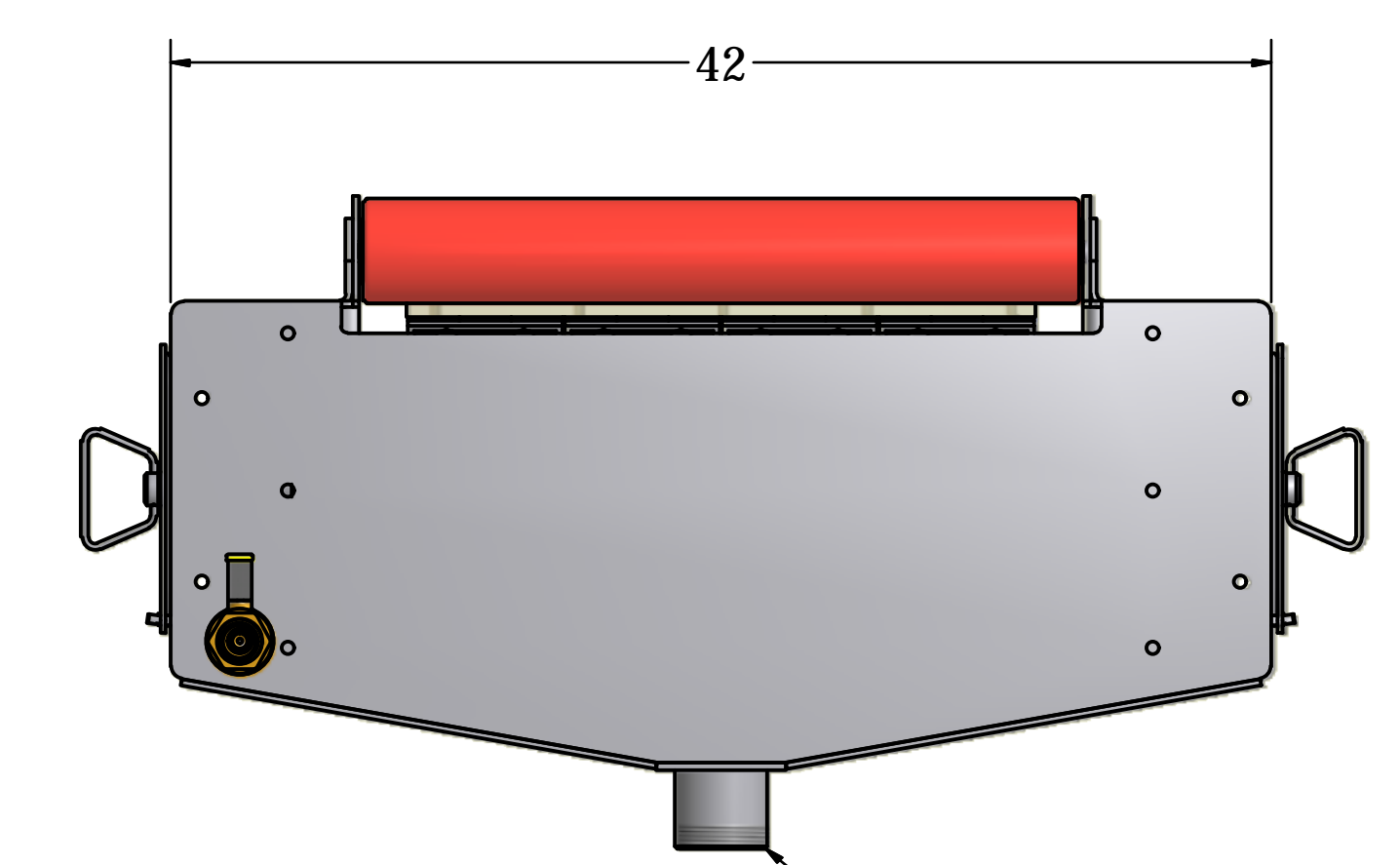

FULLY ENCLOSED WASH BOX SYSTEM PROVIDES EXCELLENT CLEANING, WHILE CONTAINING THE WASH WASTE FLUID

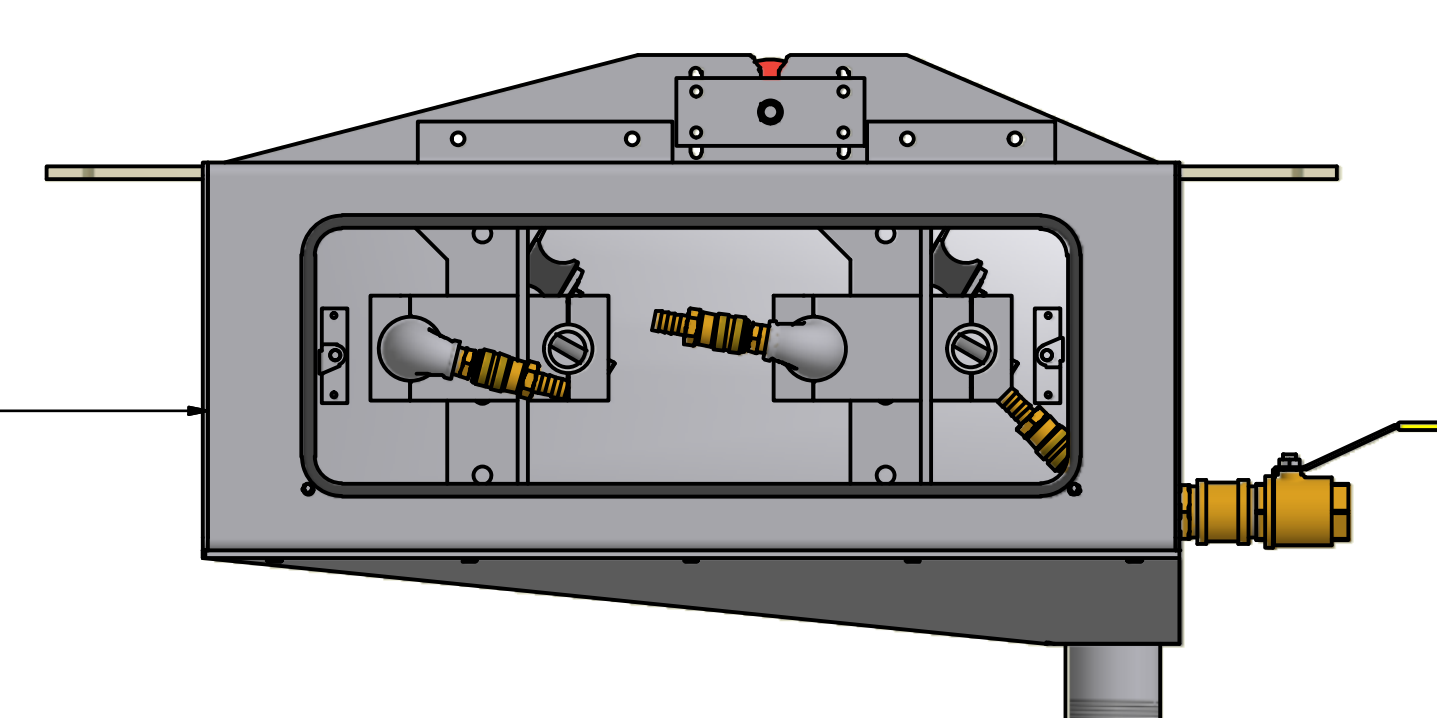

REV.	REVISION DESCRIPTION	BY

UNLESS OTHERWISE NOTED
 (Inches) (mm) (Angles)
 3 PLACES - .005 2 PLACES - .10 .5-
 2 PLACES - .010 1 PLACE - .25
 FRACTIONAL TOLERANCE - 1/64
 BREAK ALL SHARP EDGES
 Material: 1-PROP.CUSTOM
 THIS DRAWING AND THE INFORMATION THEREON IS CONFIDENTIAL AND MAY NOT BE COPIED OR USED WITHOUT THE WRITTEN PERMISSION OF ASGCO.
 DO NOT SCALE DRAWING
 DESIGNED BY: DATE: 4/17/2009
 CHECKED BY: DATE: 3/24/2009
 DRAWN BY: A.ZEHNDER

ASGCO ASGCO MANUFACTURING, INC.
 301-323 GORDON ST.
 ALLENTOWN, PA 18102-3136
 800-344-4000 OR 610-821-0218
 FAX: 610-778-8991
 www.asgco.com

PROJECT: MANUFACTURED PRODUCTS
 TITLE: MODULAR WASH BOX
 24in BW, DUAL RAZOR-BACKS, V-TIPS
 DWG. NO: ASG-MWB-24
 SHEET 1 OF 1
 REV. --

8 7 6 5 4 3 2 1