

SAFE-GUARD RETURN IDLER CAGE

Catches the return idler if it falls!

ASGCO has long recognized the importance of ensuring safety in the workplace. The **ASGCO Safe-Guard Return Idler Cage** was designed to catch the return roller applications from falling, preventing injuries to workers and to equipment. The Safe-Guard Idler Cage is a cost effective, long lasting solution to your guarding needs.

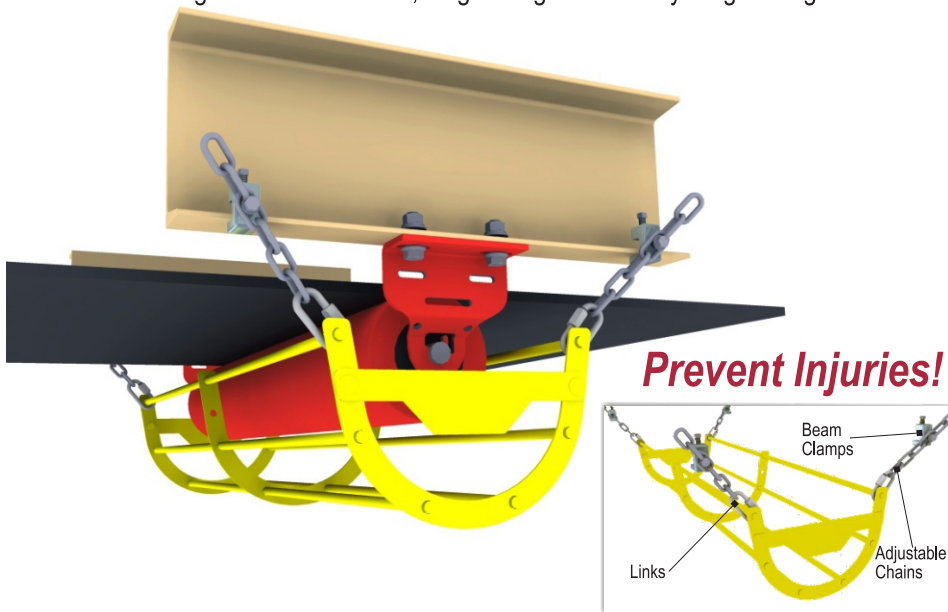

- **Prevents Idlers from Falling** - and injuring workers or equipment.
- **Easy to Install and Remove** - for fast installation and belt maintenance using beam clamp, links and adjustable chain.
- **Complies with MSHA Title 30;**
 - 56.14110 (Flying or falling material)
 - 56.14112 (Guard Construction)
 - 56.14107 (Moving machine parts)
 - 75.1722 (Mechanical equipment guards)
 - 77.400 (Mechanical equipment guards)
- **Meets OSHA Requirements 1910.219** - for mechanical power - transmission apparatus and 56.14107 for moving machine parts.
- **Durable Powder Coated A-36 Steel Cage** - helps prevent injuries from falling idlers onto unsuspecting workers or equipment. Open slots prevent material build-up.
- **Available in Various Sizes** - to fit most belt conveyors, 4" - 7" diameter rolls.
- **No Welding Required.**



Easy installation and adjustments with beam clamps and chains.



Available in all standard conveyor belt widths.



Recommended for any location where a failed idler could fall on workers or equipment, walkways, roads, etc.

RETURN IDLER CAGE

TECHNICAL INFORMATION

Available in all standard conveyor belt widths.

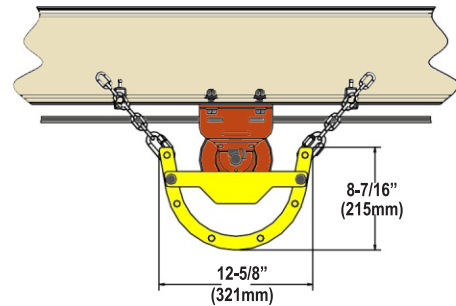
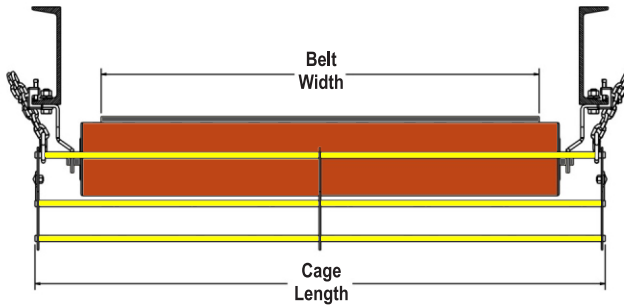

Standard Idler Guard Cage

SAFE-GUARD PART NUMBER	BELT WIDTH	CAGE LENGTH
M-ASG-RIC-18	18" (450mm)	28-7/8" (733 mm)
M-ASG-RIC-24	24" (600mm)	34-7/8" (886 mm)
M-ASG-RIC-30	30" (750mm)	40-7/8" (1038 mm)
M-ASG-RIC-36	36" (900mm)	46-7/8" (1191 mm)
M-ASG-RIC-42	42" (1050mm)	52-7/8" (1343 mm)
M-ASG-RIC-48	48" (1200mm)	58-7/8" (1495 mm)
M-ASG-RIC-54	54" (1350mm)	64-7/8" (1648 mm)
M-ASG-RIC-60	60" (1500mm)	70-7/8" (1800 mm)
M-ASG-RIC-66	66" (1650mm)	76-7/8" (1953 mm)
M-ASG-RIC-72	72" (1800mm)	82-7/8" (2105 mm)
M-ASG-RIC-78	78" (2000mm)	88-7/8" (2257 mm)
M-ASG-RIC-84	84" (2100mm)	94-7/8" (2410 mm)
M-ASG-RIC-90	90" (2300mm)	100-7/8" (2562 mm)
M-ASG-RIC-96	96" (2400mm)	106-7/8" (2715 mm)

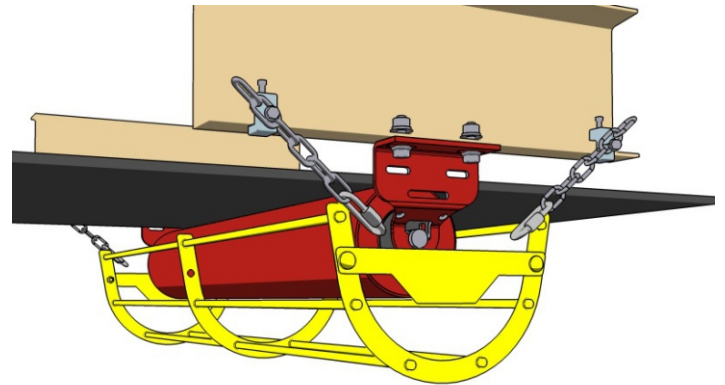

*Safe-Guard Return Idler Cages are NOT used for pinch point protection.



WARNING

Exposed moving parts can cause severe injury

LOCK OUT POWER before removing guard

CVS950020

IMPORTANT: THE SAFE-GUARD RETURN IDLER CAGE IS DESIGNED TO CATCH THE RETURN ROLLER APPLICATIONS FROM FALLING WHILE THE CONVEYOR IS RUNNING. INSTALLATION OF THIS GUARD DOES NOT SUPERSEDE ANY OTHER SAFETY PROCEDURES OR SAFETY PRACTICES. FAILURE TO OBSERVE ALL INSTRUCTIONS COULD RESULT IN SERIOUS INJURY. IT IS THE OWNER'S RESPONSIBILITY THAT THE OWNER AND EACH OPERATOR READ AND BE FAMILIAR WITH THIS MANUAL.

CAUTION: IT IS THE OWNER'S RESPONSIBILITY TO ADJUST THE SAFE-GUARD RESTRICTING CONTACT WITH THE TURNING IDLER.