



# SKALPER<sup>®</sup>

with E-Z Torque<sup>®</sup>

## INSTALLATION, OPERATION & MAINTENANCE INSTRUCTIONS

For All Skalper Blade Types

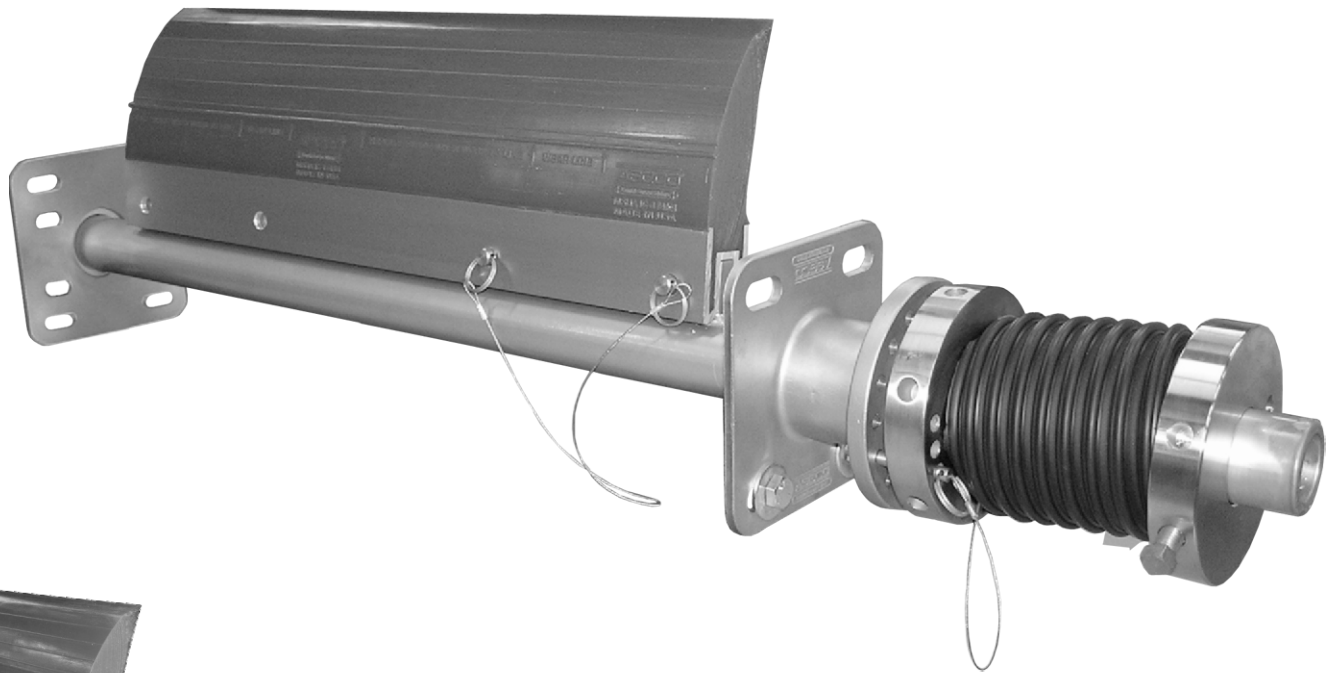

**E-Z Torque<sup>®</sup>**

U.S. Patent No. 5,992,614  
Other Patents Pending

Check us out at  
[www.asgco.com](http://www.asgco.com)

Customer Service  
**800-344-4000**



24 Hour Emergency  
Service and Parts  
610-821-0210



ASGCO Mfg., Inc.  
301 Gordon Street  
Allentown, PA 18102  
610-821-0216  
FAX 610-778-8991

## Important Safety Notice

Always observe the basic rules of safety when working with any conveyor system. To avoid injury and equipment damage, be sure that all controls to the conveyor are locked out and the power source is disconnected at all times during installation.



## Overall View

If mounting structure is not available, additional steel may have to be added. *Note: Excess mounting tube may be trimmed after installation. Also note required lubrication of components.*

## Components Diagram

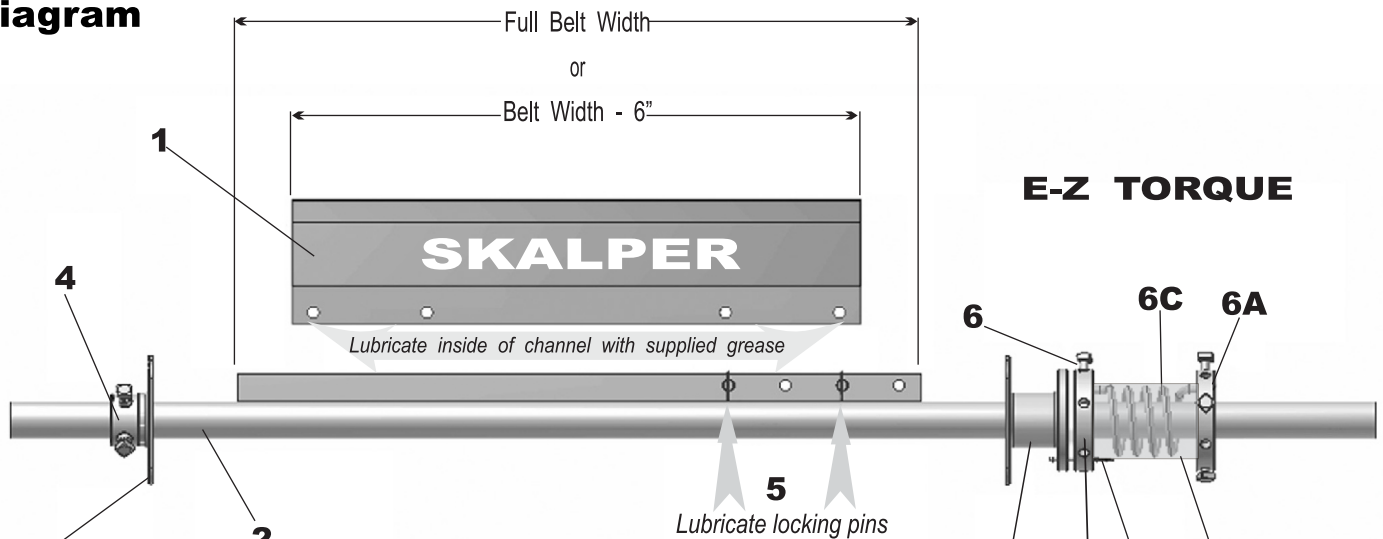

1. Skalper Blade
2. Mounting Tube
- 3A. Tensioner Mounting Plate with Bushing
- 3B. Opposite Side Mounting Plate with Bushing
4. Locking Collar with Set Screws
5. Blade Locking Pins (2)
6. E-Z Torque
- 6A. Outer Tensioner Collar with set screws
- 6B. Inner Tensioner Collar with set screw
- 6C. Spring (Heavy Duty Spring for 48" belt and wider)
- 6D. Tensioner Locking Pin
- 6E. Spring Cover

## 1. Determine the Critical "N" Dimension

Determining the "N" dimension, the distance from the belt surface to the mounting tube center, is critical to get the maximum cleaning performance from your system. Make sure mounting tube and tensioner system are clear of obstacles.

<b>"N" Dimension Table</b>	
Pulley Diameter inches [mm]	"N" Dimension inches [mm]
Note the tolerance is $\pm \frac{1}{4}$ " [6mm]	
12" [300mm]	4-3/4" [120mm]
14" [350mm]	4-1/2" [115mm]
16" [400mm]	4-1/4" [110mm]
18" [450mm]	4" [100mm]
20" [500mm]	4" [100mm]
24" [600mm]	3-3/4" [95mm]
30" [750mm]	3-1/2" [90mm]
36" [900mm] PLUS	3-1/4" [85mm]

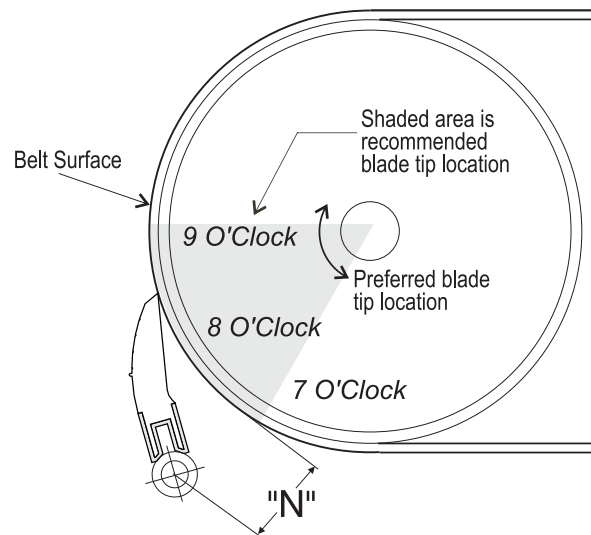
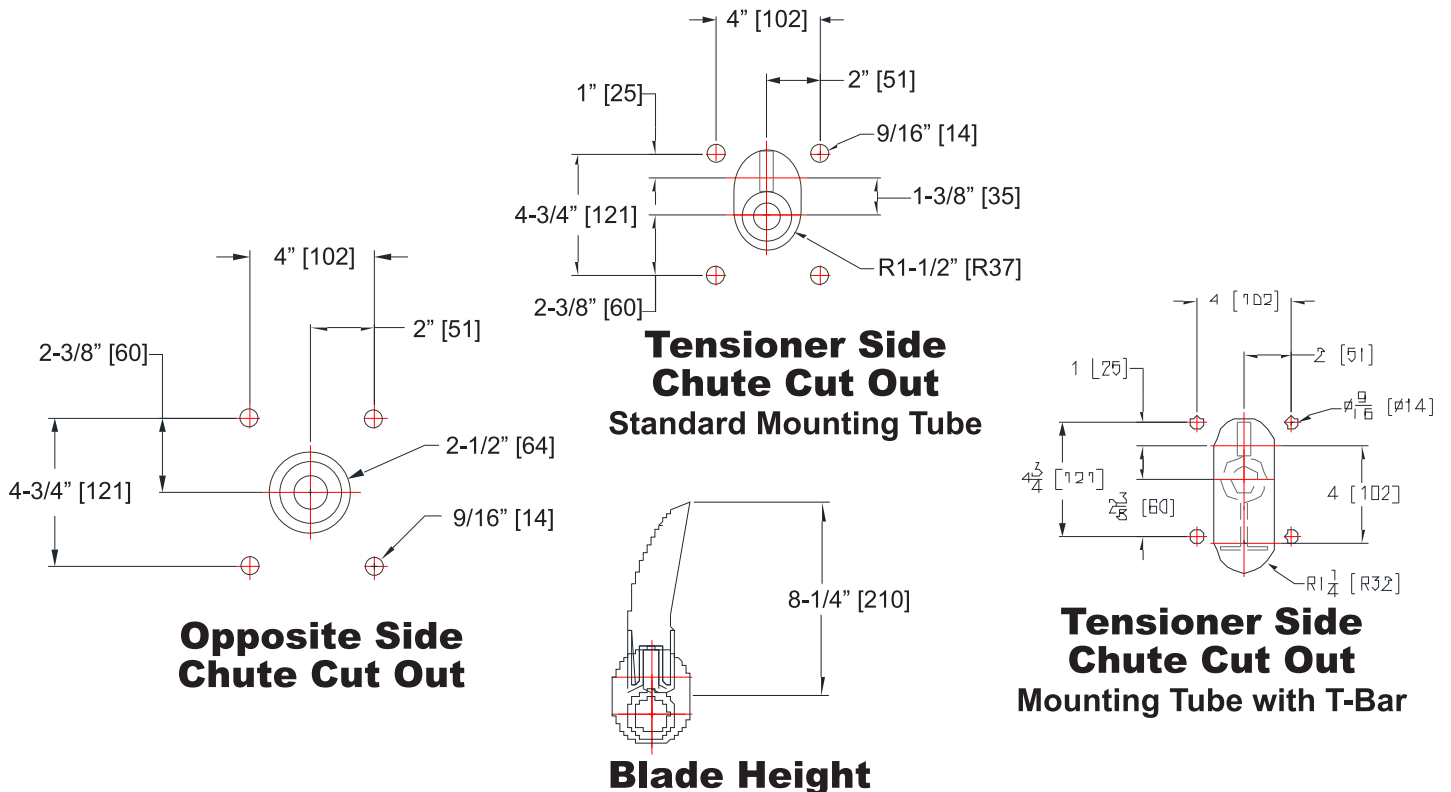

Figure 1: Typical Mounting Position  
Note:  $\pm \frac{1}{4}$ " tolerance

## 2. Cut Chute Openings

Determine the desired location of the mounting brackets. The required slot sizes/locations are shown for the tensioner side chute cut outs.



### 3. Put Mounting Tube through Cut Outs

Place the mounting tube through the chute cut outs so that the long tube section is on the tensioner side. Place the blade onto the blade holder. Visually check the blade position and contact with the belt/pulley.

### 4. Mount Brackets

Determine the desired location of the mounting brackets. Attach the mounting brackets to the conveyor frame by welding or bolting.

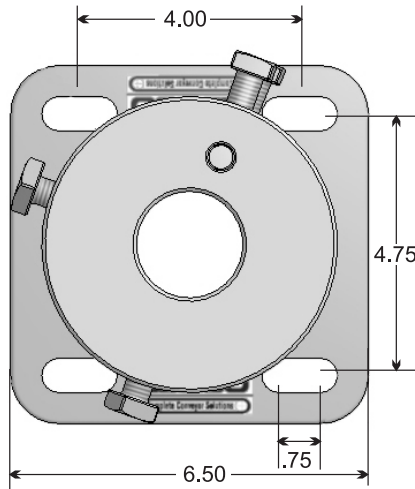

**Tensioner Side**

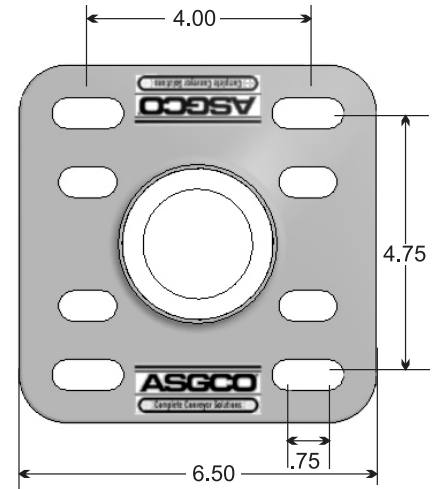

**Opposite Side**

### 5. Select Correct Spring

Each E-Z Skalper System is shipped with two springs of opposite handedness. To determine the proper spring to use:

Face the head pulley as the material would come to you. If the E-Z torque tensioner is on the *right* side, then use the Silver Spring (entire spring is silver-grey). If the tensioner is to your *left*, then use the Gold Spring (yellow tipped spring).

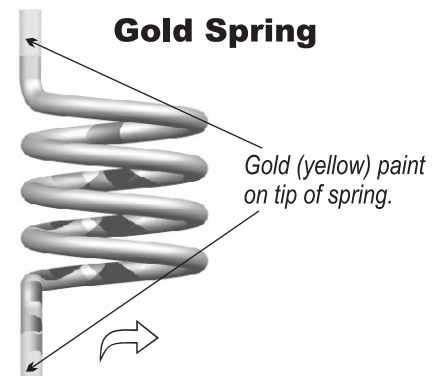
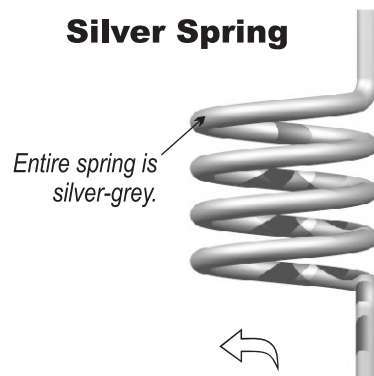

### 6. Assemble E-Z Torque Tensioner:

Assemble the components of the E-Z Torque tensioner. Tighten all set screw to 70 ft./lbs.

# OPERATION & MAINTENANCE

## Tension Assembly

- 1.) Set torque to approximately one (1) lb. of force per inch of blade width - approximately 30 lbs of force for a 30" blade. For the standard duty spring, 1 degree of collar rotation will apply about 1 ft-lb of torque (1 ft-lb torque will give approximately 1 lb force at the blade tip). For the heavy duty spring, assume approximately 2 ft-lbs of torque per degree of rotation. Decrease or increase the torque as necessary. Using the minimum amount of blade force required to clean the belt will extend blade life. The tensioning rod will enable approximate blade tensioning. Use a torque wrench with adapter to more accurately tension the blade.

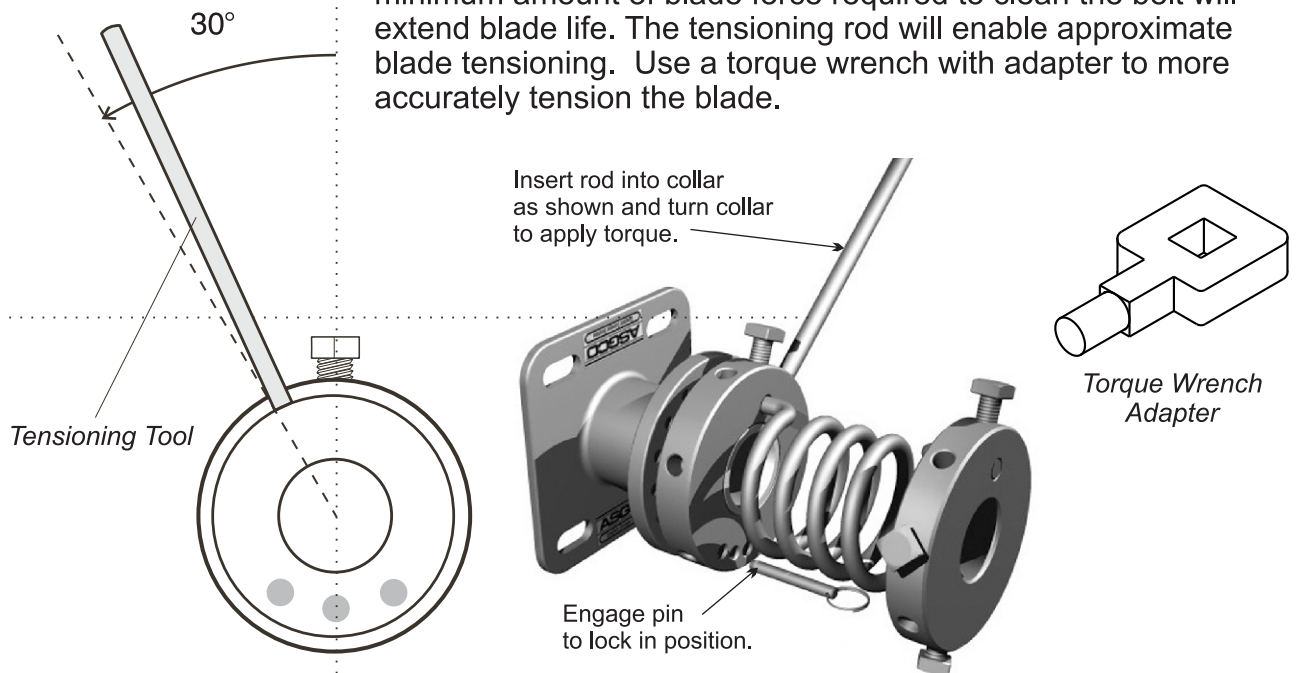

- 2.) Frequent inspections the key to proper belt cleaning and easy scraper servicing. Weekly inspections are recommended, but actual service frequency may vary widely depending on various plant operating conditions.
- 3.) Inspect the belt surfaces and edges for cracks, splits, tears, holes or any other worn or damaged condition occurring on the surfaces or edges of the belt itself. If necessary make repairs to the belt. Wash the entire cleaner regularly to prevent excessive build-up. Check the tightness of all fasteners.
- 4.) Inspect for proper operation. Adjust tension as required.
- 5.) Replace the Skalper scraper blade as required. Use only ASGCO Manufacturing approved replacement scraper blades.

## Information

Key	Description	Part Number
1	Skalper Blade Replacement	ASG-SK[X]-[BW]-A [X]=Blade Type, [BW]=Blade Width
2	Mounting Tube	ASG-SKMT-[BW]-A
3A	Mounting Bracket Tension Side	ASG-EZT-TS-ASM-1 (Includes Inside Collar)
3B	Mounting Bracket Opposite Side	ASG-F1-MB-OS
	Bushing (Off-Side)	ASG-F1-UHMW-BUSHING
4	Locking Collar with Set Screws	ASG-F1-LC
5	Locking Pins (2)	M-ASG-SKMT-CL
6	E-Z Torque	M-ASG-EZT-1 (M-ASG-EZT-A-1)
	Bushing (Tension Side)	ASG-EZT-BUSHING
6A	Outside Collar	ASG-EZT-OCHS-SS-1
6B	Inside Collar	ASG-EZT-ILC-SS-1
6C	Spring	ASG-ROT-[LS or RS]-{1242 or 4896}
6D	Locking Pin (Tensioner)	M-ASG-ROT-LPC
	Rotary Tensioning Tool	ASG-ROT-TT

Call your ASGCO Distributor for any questions or replacement parts

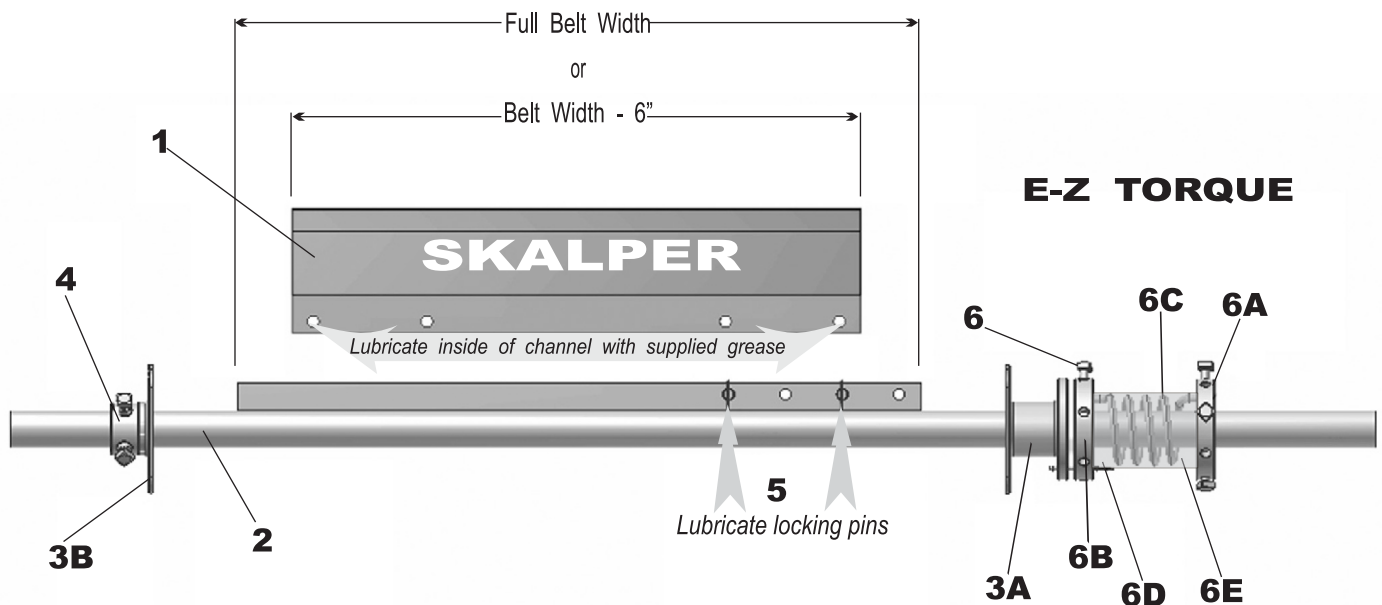

## TROUBLE SHOOTING

<b>PROBLEM</b>	<b>SOLUTION</b>
<i>Excess vibration of the scraper.</i>	<p>Make certain all bolts are tight and the pin is securely engaged on the tensioner.</p> <p>Ensure the cleaners n-dimension is proper (See Table and Figure 1).</p>
<i>Excess carryback.</i>	<p>Check for excess build-up on the scraper.</p> <p>Check for proper Scraper tension. Put additional tension on cleaner.</p> <p>Check for non-uniform scraper wear.</p> <p>Check N-dimension.</p> <p>Clean the back-side of the belt cleaner.</p>
<i>Check for wear on the cleaning tips.</i>	<p>Check thickness of carry-back. If the cleaner must remove more than about 1/8" of material then an additional cleaner may be needed.</p>
<i>Frozen material on scraper.</i>	<p>Place heaters near scraper to melt frozen material. (Use caution not to burn belt or cleaner)</p>
<i>Blade wearing in center</i>	<p>Install a new blade that concentrates cleaning in the center of the flow of the material. (Belt Width - 6" or Belt Width - 12")</p>
<i>Blade wearing more on one side</i>	<p>Check N-dimension.</p>