

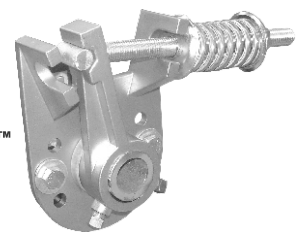

SKALPER[®] with Force-1[™]

INSTALLATION, OPERATION & MAINTENANCE INSTRUCTIONS

For All Skalper Blade Types: Skalper IV[®], Skalper II, High Temp
& Ultra High Temp

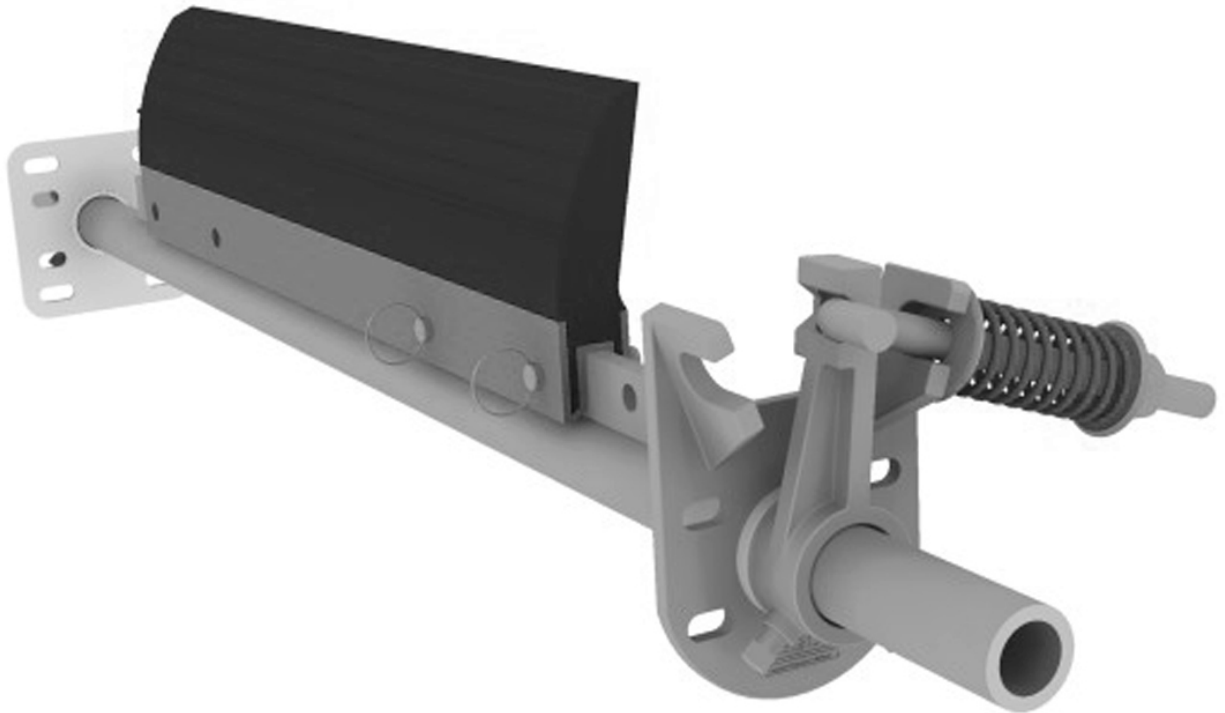

Force-1[™]

Check us out at
www.asgco.com

Customer Service
800-344-4000



24 Hour Emergency
Service and Parts
610-821-0210



ASGCO Mfg., Inc.
301 Gordon Street
Allentown, PA 18102
610-821-0216
FAX 610-778-8991

Important Safety Notice

Always observe the basic rules of safety when working with any conveyor system. To avoid injury and equipment damage, be sure that all controls to the conveyor are locked out and the power source is disconnected at all times during installation.



Overall View

If mounting structure is not available, additional steel may have to be added. *Note: Excess mounting tube may be trimmed after installation. Also note required lubrication of components.*

Components Diagram

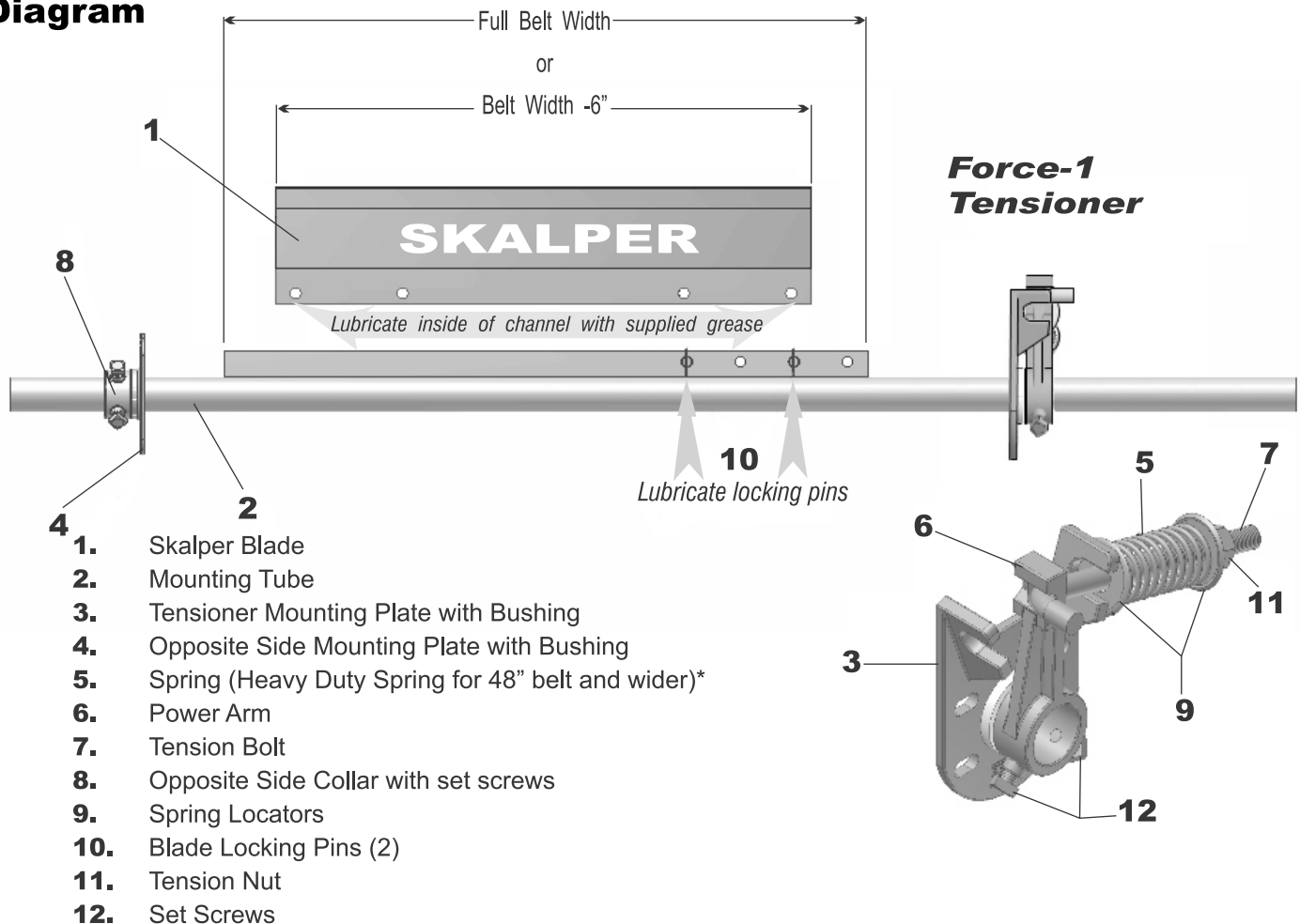

*Note: Light-duty spring is red; heavy duty spring is silver

SKALPER™ w/Force-1

1. Determine the Critical "N" Dimension

Determining the "N" dimension, the distance from the belt surface to the mounting tube center, is critical to get the maximum cleaning performance from your system. Make sure mounting tube is clear of obstacles.

"N" Dimension Table	
Pulley Diameter	"N" Dimension
Note the tolerance is $\pm 1/4$"	
8"	5-3/4"
10"	5-3/8"
12"	5"
14"	4-5/8"
16"	4-1/4"
18"	4"
20"	3-7/8"
24"	3-1/2"
30"	3-1/4"
36" thru 42"	3"
48" thru 60"	3"

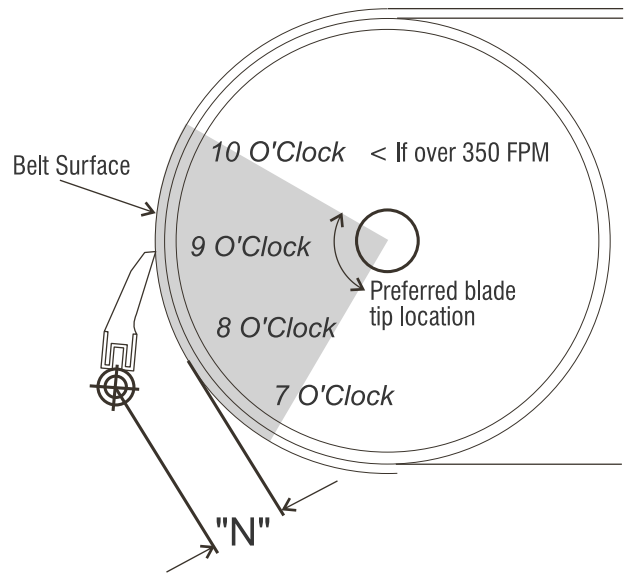
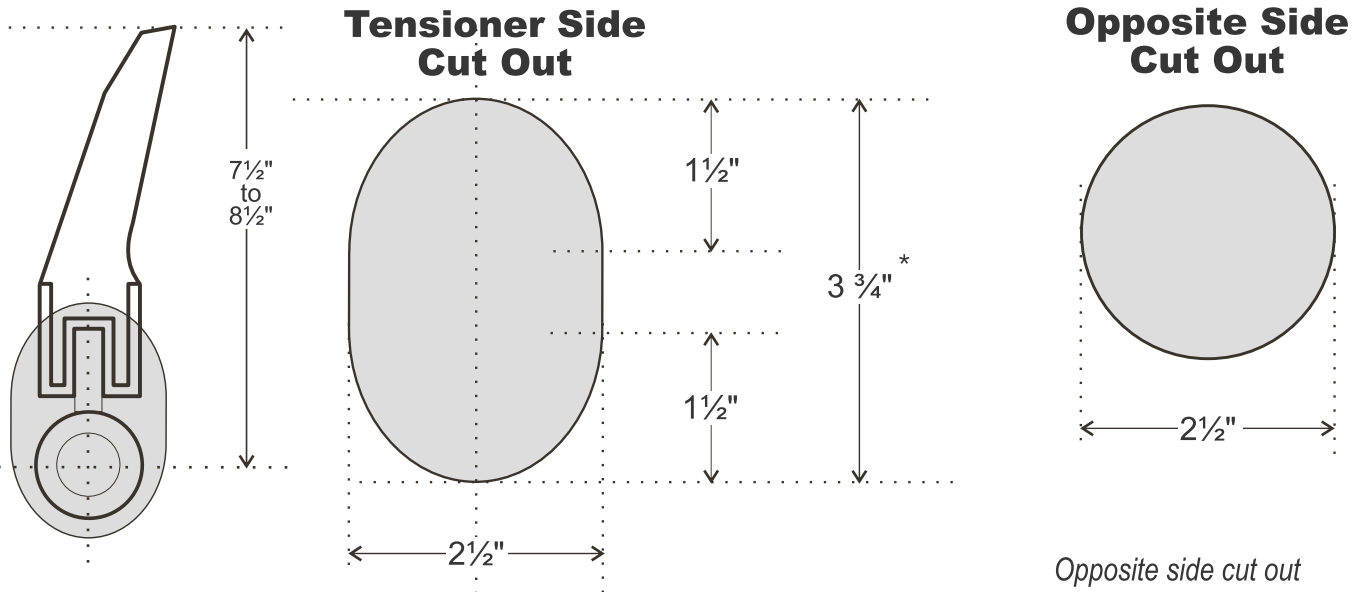

Figure 1: Typical Mounting Position
 *Note: $\pm 1/4$ " tolerance

2. Cut Chute Openings



*Dimension is 6" for BW 72" and greater

Opposite side cut out is a 2 1/2" hole to install mounting tube

3. Mounting Tube through Cut Outs

Place the mounting tube through the chute cut outs so that the long tube end section is on the tensioner side. Place the blade onto the blade holder. Visually check the blade position and contact with the belt/pulley.

4. Selecting Correct Orientation

The location of the tensioner determines the orientation of the spring / bolt / arm assembly. Facing the head pulley as material would come towards you, configure the tensioner as shown:

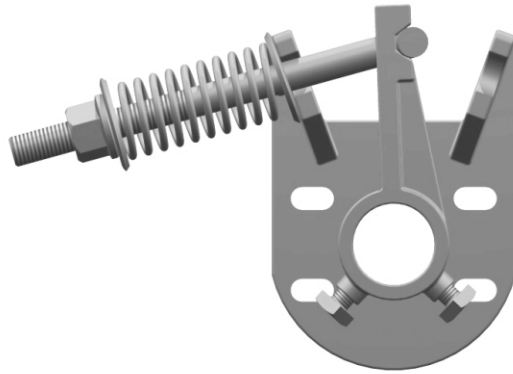

Assemble this way if tensioner is on the left.

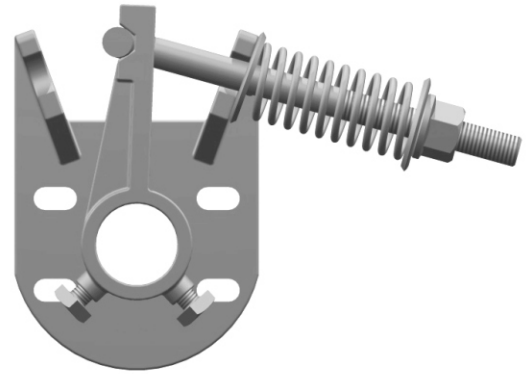

Assemble this way if tensioner is on the right.

6.50

5. Mounting Brackets

Determine the desired location of the mounting brackets. Attach the mounting brackets to the conveyor frame by welding or bolting.

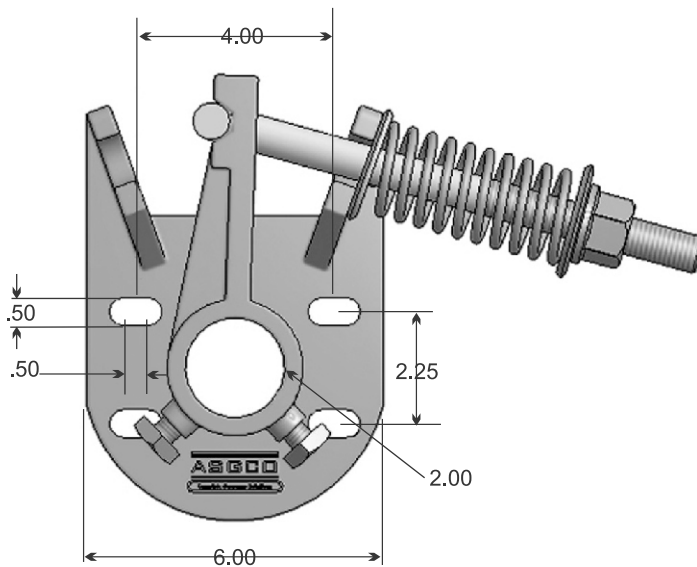

Tensioner Side

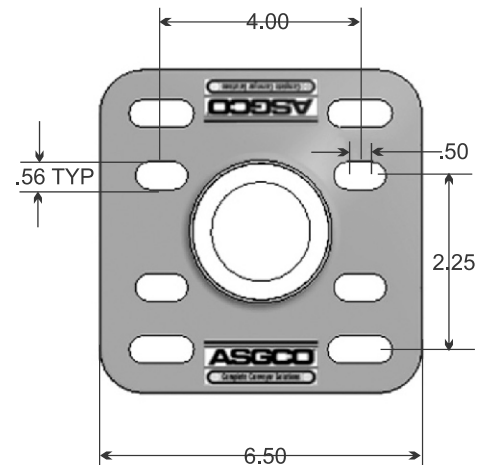

Opposite Side

OPERATION & MAINTENANCE

Tensioning the Force-1 Tensioner

- 1.) The following chart shows the “D” dimensions for a particular blade width. Once Force-1 tensioner in place, tighten all set screws to 70 ft-lbs (95 N-m).

	BLADE	"d" DIMENSION
STARTING DIMENSION = 3.6250"		
LIGHT DUTY SPRING (RED)	18	3.125
	24	3.000
	30	2.750
	36	2.625
	42	2.375
HEAVY DUTY SPRING (SILVER)	48	3.375
	54	3.250
	64	3.125
	72	2.875
	84	2.625

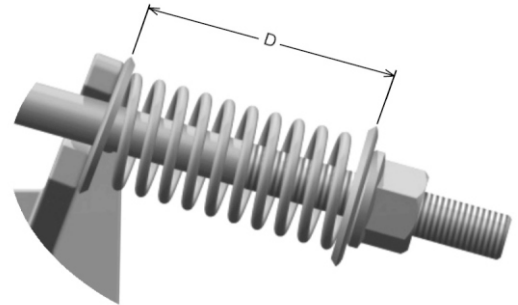

- 2.) Select the “D” dimension for your application from the table above. Use the hex nut to adjust the spring force via the “D” dimension. Begin with $D = 3.625$ (roughly) and tighten until the proper value is reached.

The “D” dimension relates to approximately one (1) lb. of force per inch of blade width - approximately 30 lbs of force for a 30" blade. Observe the operation of the Skalper blade. Loosen the nut until cleaning performance suffers; then tighten it slightly to obtain adequate cleaning. Using the minimum amount of blade force required to clean the belt will extend blade life.

- 3.) Frequent inspections the key to proper belt cleaning and easy scraper servicing. Weekly inspections are recommended, but actual service frequency may vary widely depending on various plant operating conditions.
- 4.) Inspect the belt surfaces and edges for cracks, splits, tears, holes, or any other worn or damaged condition occurring on the surfaces or edges of the belt itself. If necessary, make repairs to the belt. Wash the entire cleaner regularly to prevent excessive build-up. Check the tightness of all fasteners.
- 5.) Inspect the cleaner for proper operation. Adjust torque as required.
- 6.) Replace the Skalper blade as required. Use only ASGCO Manufacturing approved replacement scraper blades

Information

Key	Description	Part Number
1	Skalper Blade Replacement	ASG-SBB-[BW]-A [X]=Blade Type, [BW]=Blade Width
2	Mounting Tube	M-ASG-SKMT-(BW)-A (BW) Belt Width
3	Mounting Bracket Tension Side	ASG-F1-MB-TS
4	Mounting Bracket Opposite Side	ASG-F1-MB-OS-1
	Bushing (Off-Side)	ASG-F1-UHMW-BUSHING
5	Coil Spring	ASG-ECONO-T-[XXXX]-SPRING [XXXX] = 1242 OR 4896
6	Power Adjustment Arm	ASG-F1PAA
7	Tensioner Bolt	ASG-ECONO-T-AB-3/4X10-1/2
8	Opposite Side Collar w-Set Screws	ASG-F1-LC
9	Spring Locator	ASG-ECONO-T-SL
10	Locking Pins (2)	M-ASG-SKMT-CL
11	Tension Nut	ASG-NUT-3/4G5
12	Set Screw	AS-SSH-8X1.0-NCG8
	Force-1 Tensioner	M-ASG-DURA-T (Belt Width 48" + : M-ASG-DURA-T-A)
	Bushing (Tension Side)	ASG-F1-UHMW-BUSHING

Call your ASGCO Distributor for any questions or replacement parts

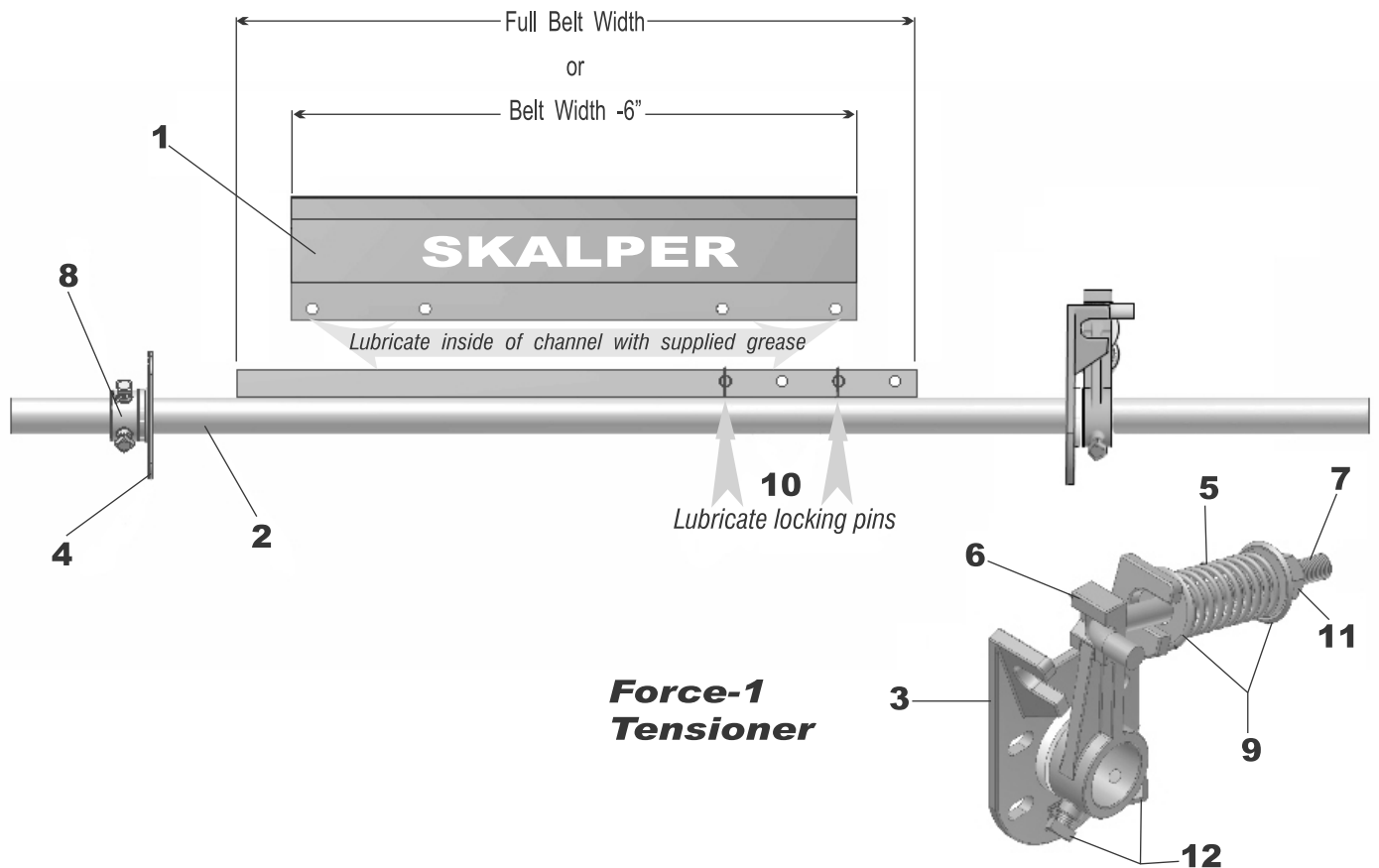

TROUBLE SHOOTING

PROBLEM	SOLUTION
<i>Excess vibration of the scraper.</i>	<p>Make certain all bolts are tight and the pin is securely engaged on the tensioner.</p> <p>Ensure the cleaners N-dimension is proper (See Table and Figure 1).</p>
<i>Excess carryback.</i>	<p>Check for excess build-up on the scraper.</p> <p>Check for proper scraper tension. Put additional tension on cleaner.</p> <p>Check for non-uniform scraper wear.</p> <p>Check N-dimension.</p> <p>Clean the back-side of the belt cleaner.</p>
<i>Check for wear on the cleaning tips.</i>	<p>Check thickness of carryback. If the cleaner must remove more than about 1/8" of material then an additional cleaner may be needed.</p>
<i>Frozen material on scraper.</i>	<p>Place heaters near scraper to melt frozen material. (Use caution not to burn belt or cleaner)</p>
<i>Blade wearing in center</i>	<p>Install a new blade that concentrates cleaning in the center of the flow of material (Belt Width 6" or Belt Width 12")</p>
<i>Blade wearing more on one side</i>	<p>Check N-dimension.</p>