

CAN DIAMETER: _____

FACE LENGTH: _____

RISE: _____

QUANTITY: _____

D.A.H. MINIMUMS:
 4" FACE = 9"
 5" FACE = 10"
 6" FACE = 11"

REV. NO.	DATE	REV. INDICATION	CHG DONE BY.	BY.	INFO
X	XXXX	REVISION DESCRIPTION	XXX	XXX	

INFORMATION CONTAINED IN THIS DRAWING IS FOR REFERENCE ONLY. DIMENSIONS AND MATERIALS OF PARTS ARE SUBJECT TO CHANGE WITHOUT NOTICE. FOR CURRENT INFORMATION CONTACT ASGCO MFG., INC. AT (610) 821-0216 www.asgco.com

DATE: 1/21/2014
 SCALE: D.A.S.
 CHECKED: XXXX
 DRAWN BY: XXXX

PROJECT: CEHA E - SINGLE RETURN GUIDE IDLER
 CUSTOMER NAME & PO NUMBER: _____
 DWG. NO.: 1 OF 1

ASGCO MANUFACTURING, INC.
 20 GORDON STREET
 ALTOONA, PA 15701
 610-821-0216

CAN DIAMETER: _____

FACE LENGTH: _____

RISE: _____

QUANTITY: _____

D.A.H. MINIMUMS:
4" FACE = 10"
5" FACE = 11"
6" FACE = 12"

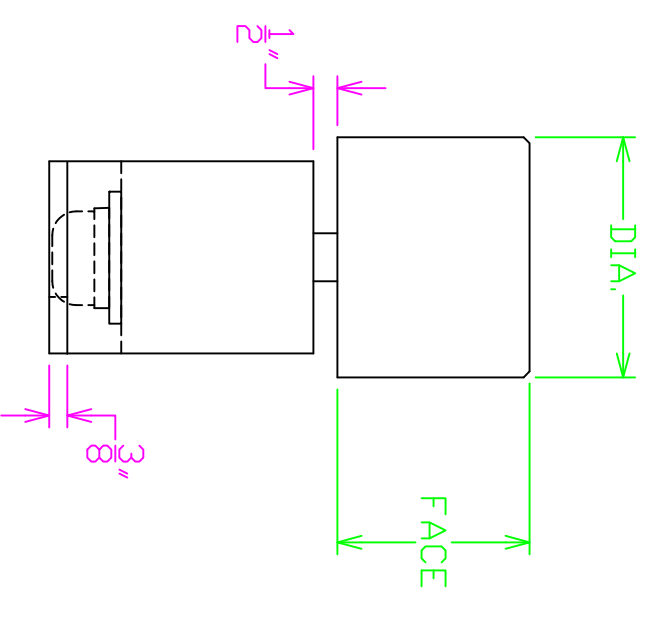
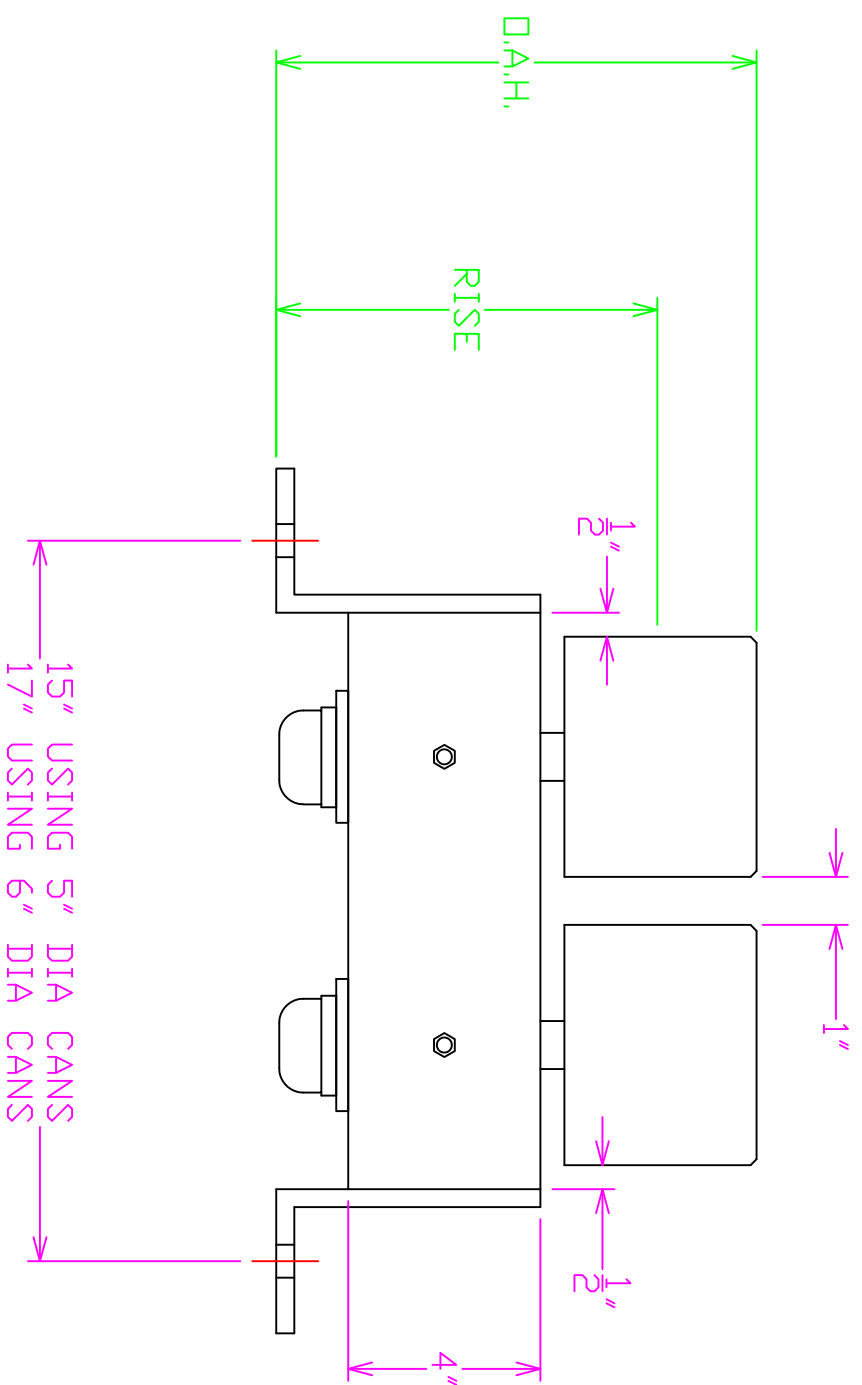
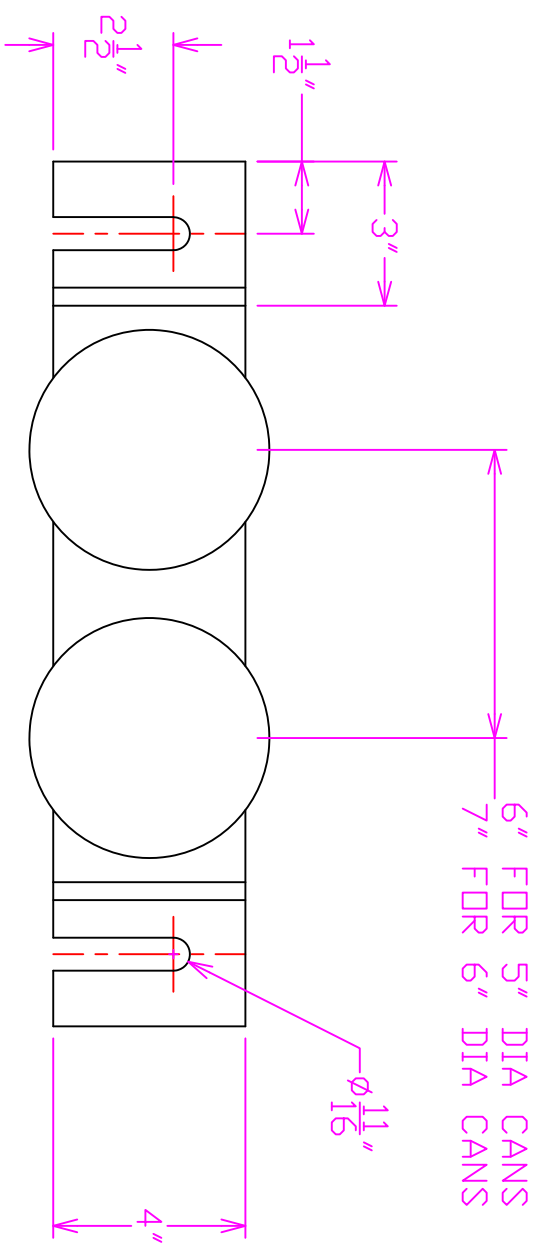

REV. NO.	DATE	REV. INDICATION	CHGD BY	DONE BY
X	XXXX	XXXXX	XXX	XXX

INFORMATION CONTAINED IN THIS DRAWING IS FOR REFERENCE ONLY. DIMENSIONS AND MATERIALS OF CONSTRUCTION ARE SUBJECT TO CHANGE WITHOUT NOTICE. FOR CURRENT INFORMATION CONTACT ASGCO MFG., INC. ENGINEERING DEPARTMENT AT (610) 821-0216 www.ASGCO.com

ASGCO MANUFACTURING, INC.
301 GORDON STREET
ALLENTOWN, PA 18102
800-344-4000

DATE: 4/18/2014 SCALE: D.N.S. CHECKED: XXXXX DRAWN BY: J. FRIES

PROJECT: CEMA E - DUAL CARRY GUIDE IDLER DWG. NO. 1 OF 1

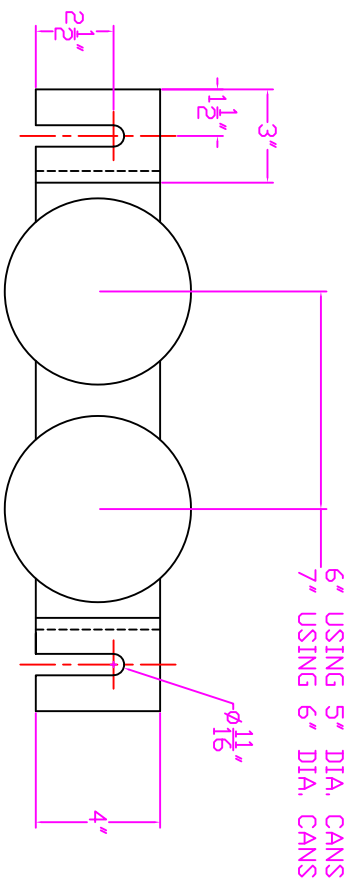

CAN DIAMETER: -----

FACE LENGTH: -----

RISE: -----

QUANTITY: -----

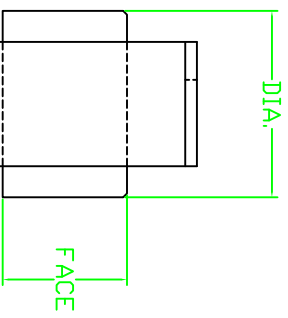
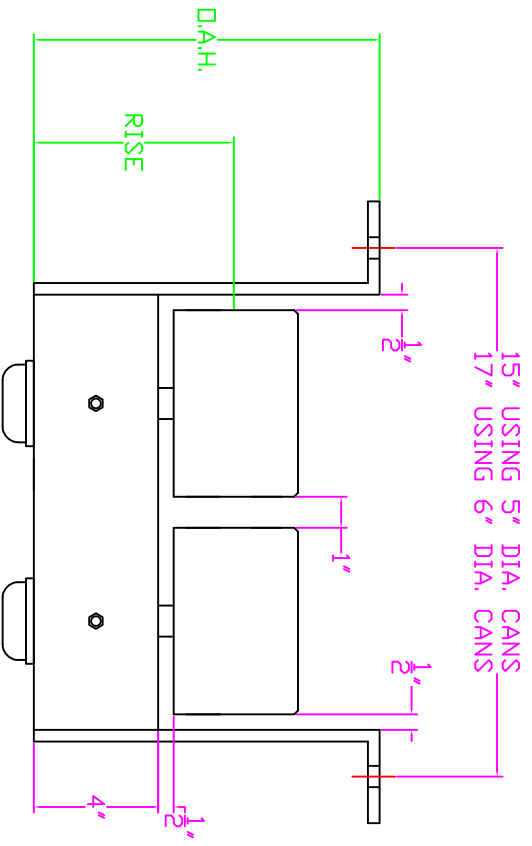

D.A.H. MINIMUMS:
 4" FACE = 9"
 5" FACE = 10"
 6" FACE = 11"

REV. NO.	DATE	REV. INDICATION	CHG DONE BY.	BY.	DATE	INFORMATION CONTAINED IN THIS DRAWING IS FOR REFERENCE ONLY. DIMENSIONS AND MATERIALS OF PARTS ARE SUBJECT TO CHANGE WITHOUT NOTICE. FOR CURRENT INFORMATION CONTACT ASGCO MFG., INC. (810) 821-0218 www.asgco.com
X	XXXX	XXXXX	XXXX	XXX	XXX	

	ASGCO MANUFACTURING, INC. 20 GORDON STREET ALTON, OH 45710 810-821-0218
DATE: 1/21/2014 SCALE: D.A.S. DRAWN BY: XXXX CHECKED BY: XXXX DATE: 1/21/14	PROJECT: CEJA E - DUAL RETURN GUIDE IDLER CUSTOMER NAME & PO NUMBER: _____ 1 OF 1