

ASGCO

Complete Conveyor Solutions



TORO[®]

*Reversing Secondary Belt Cleaner
with Bolt-Up™ Tensioner*

INSTALLATION, OPERATION & MAINTENANCE INSTRUCTIONS

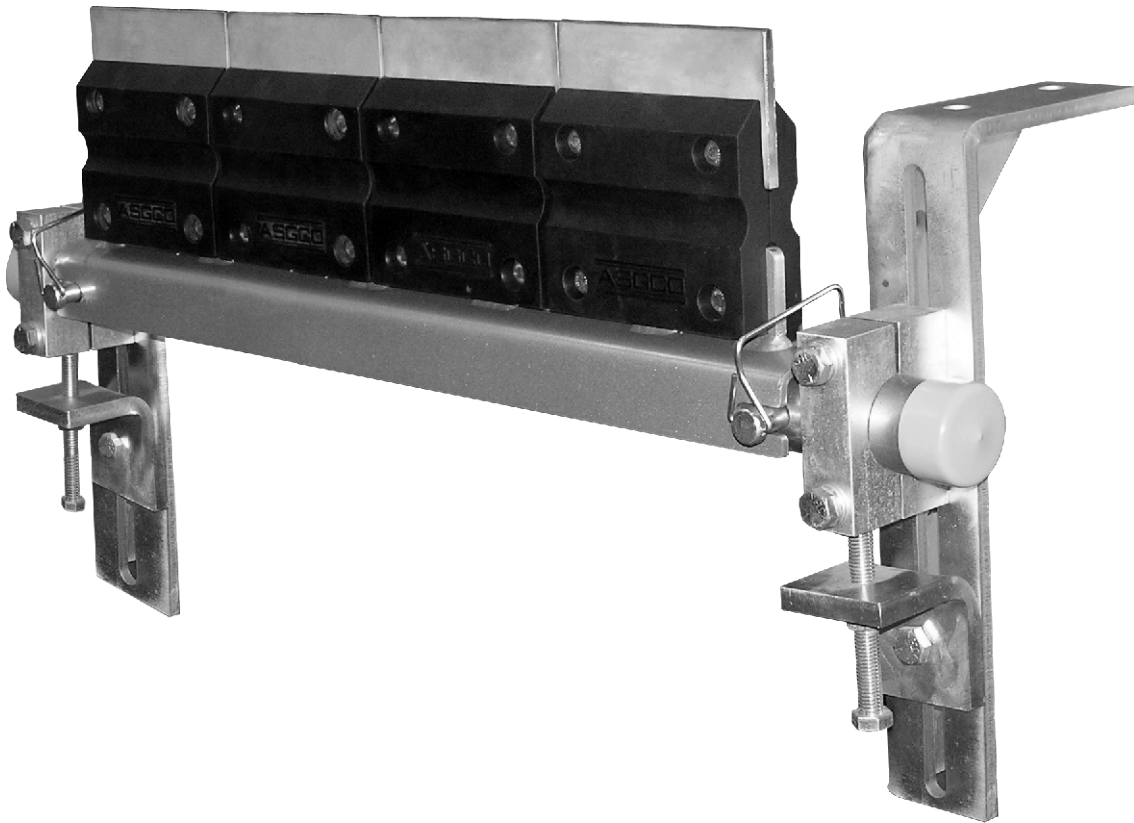

Check us out at
www.asgco.com

Customer Service
800-344-4000



24 Hour Emergency
Service and Parts
610-821-0210

ASGCO Mfg., Inc.
301 Gordon Street
Allentown, PA 18102
610-821-0216
FAX: 610-778-8991

**Important
Safety
Notice**

Always observe the basic rules of safety when working with any conveyor system. To avoid injury and equipment damage, be sure that all controls to the conveyor are locked out and the power source is disconnected at all times during installation.

Overall View

If mounting structure is not available, additional steel may have to be added. *Note: Excess mounting tube may be trimmed after installation.*

**Components
Diagram**

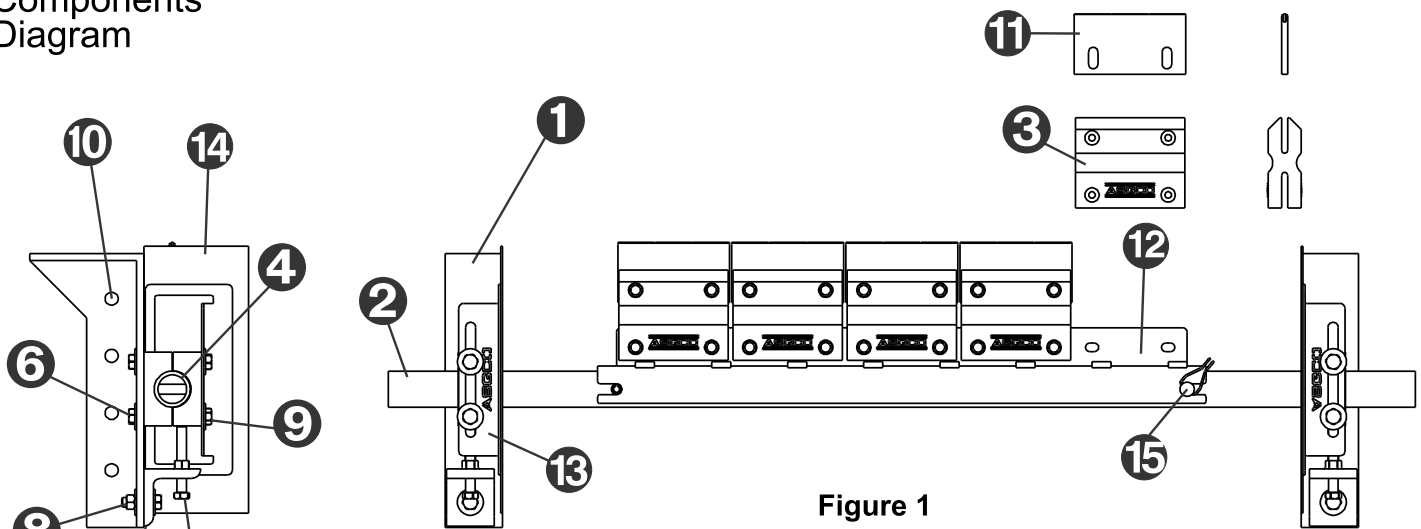

Figure 1

- | | |
|-------------------------------|-------------------------|
| 1. Mounting Bracket | 9. Tube Clamp Lock Bolt |
| 2. Mounting Tube | 10. Mounting Holes |
| 3. Blade Cushion | 11. Blade Tips |
| 4. Support Tube Clamp | 12. Blade Holder |
| 5. Adjustment Angle | 13. Dust Guard Bracket |
| 6. Support Tube Clamp Bolt | 14. Rubber Dust Shield |
| 7. Adjustment Bolt | 15. Locking Pin |
| 8. Adjustment Angle Lock Bolt | |

**Determine Cleaner
Mounting Location**

The TORO is a reversing secondary belt cleaner and as such should be located on the return side of the belt after the belt leaves contact with the head pulley as shown below. Preferably it should be located within the confines of the head or dribble chute.

Note that the bracket can be flipped either way to bolt to existing structure. See Fig. 2.

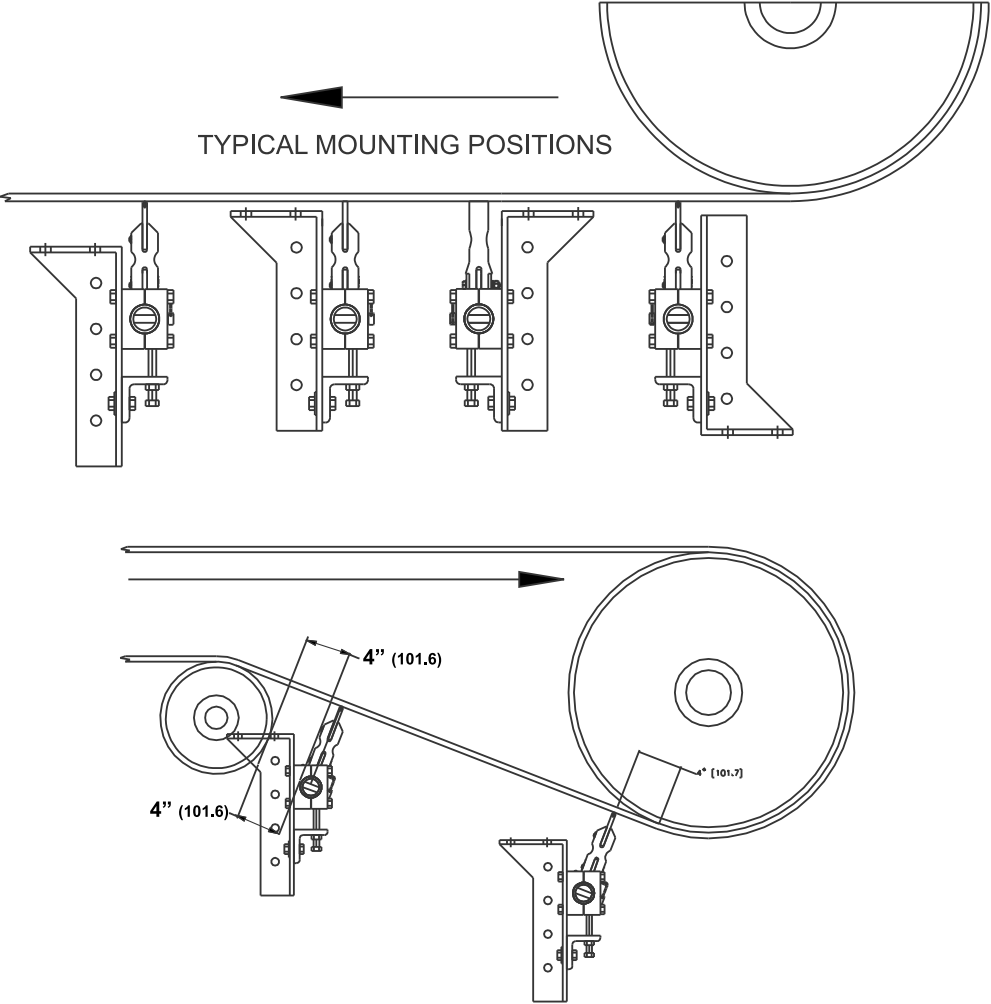

Figure 2

Cutting the Chute Openings

If the brackets are to be mounted to an enclosed chute, an elongated hole will have to be cut into the chute wall to allow the blades and the mounting tube to pass through from one side of the conveyor to the other. See Fig. 3.

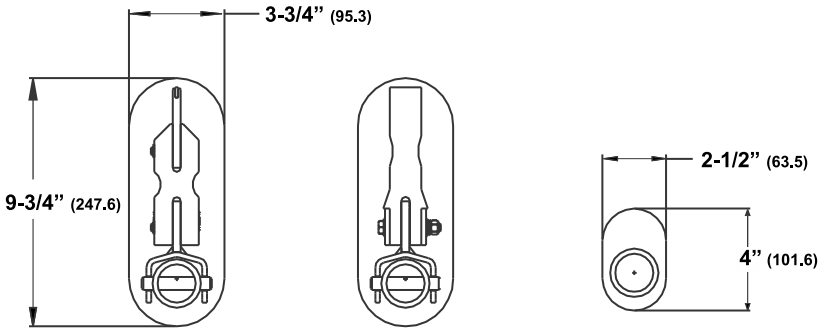

Figure 3

Mounting Brackets

Insert the tube with attached blades through the chute cut outs. Determine the desired position of the mounting brackets. Attach the mounting brackets to the chute wall by welding or bolting through the mounting holes along the mounting brackets' length, or to the conveyor frame using the two holes on top of each mounting bracket.

Installing Cleaner with Dust Guards

With mounting brackets bolted or welded in place, insert the tube with attached blades through the chute cut outs.

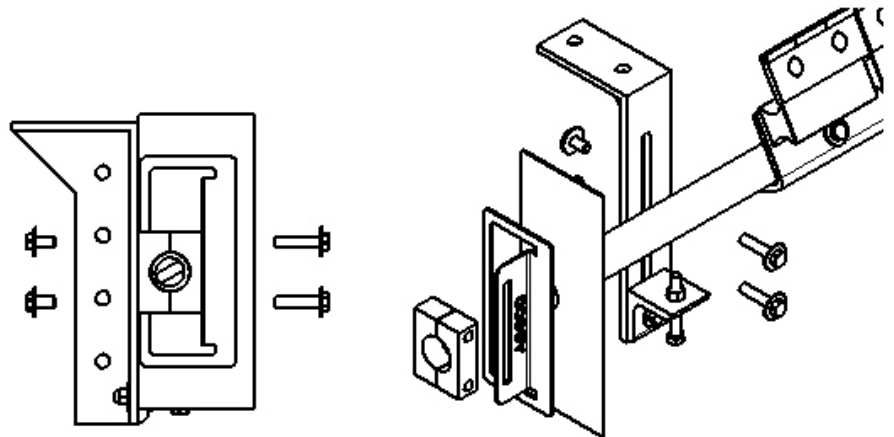

1. Gather components for one complete side.

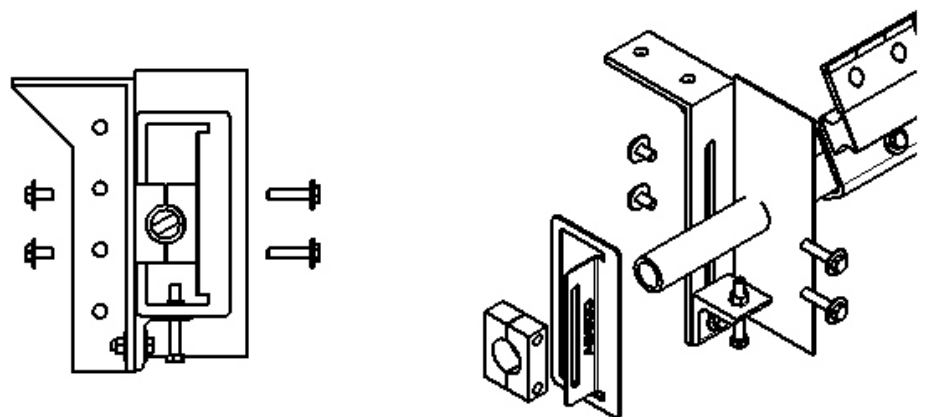

2. Slide rubber dust shield over end of support tube and flush against the enclosed chute wall.

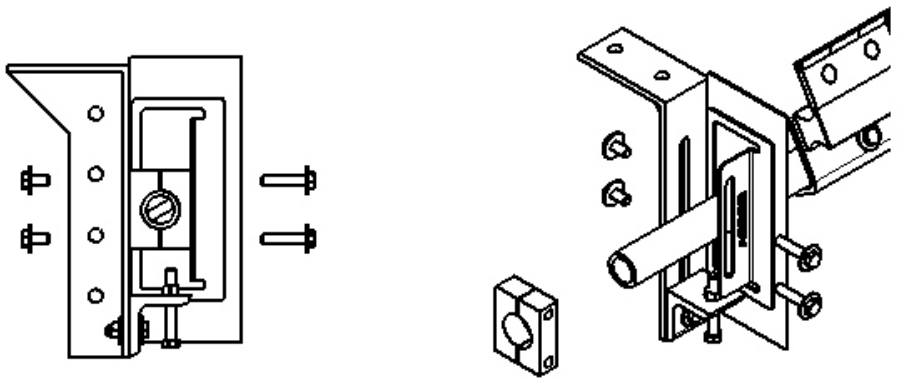

3. Slide dust guard bracket over end of support tube and flush against the rubber dust shield.

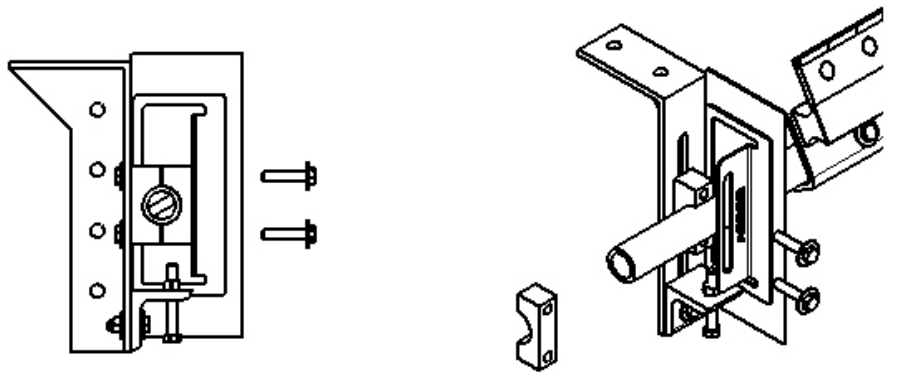

4. Place the support tube clamp with the threaded holes between the mounting bracket and the support tube. Then loosely secure the support tube clamp in the bracket's slot using the two tube clamp lock bolts.

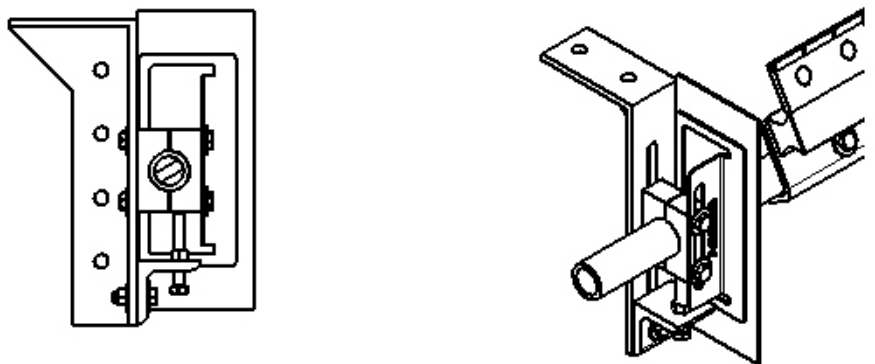

5. Secure adjustment angle so that the blade tip is perpendicular with the belt surface by tightening the adjustment angle lock bolt. Then bring the cleaner in contact with the belt by raising the adjustment bolt and tightening the support tube clamp bolts.

Repeat steps 1-5 for opposite side of cleaner.

OPERATION

After the mounting bracket is attached to the conveyor frame, assemble the cleaner to the bracket.

Bolt the support tube clamp to the bracket using the tube clamp lock bolts as shown in Fig. 4 Position the support tube into the fixed half of the support tube clamp as shown in Fig. 5 Bolt the top half of the support tube clamp into place and make sure that the blade tip is perpendicular to the belt as shown in Fig. 6

Raise both the Support tube clamp and the Adjustment angle in the slot of the mounting bracket until the tip of the blade touches the belt as shown in Fig. 7

Once belt contact has been made, tighten the adjustment angle lock bolt. Turn the adjustment bolt until the blade tip has moved about $\frac{1}{4}$ ". Tighten the tube clamp lock bolts.

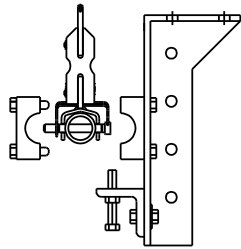

Fig. 4

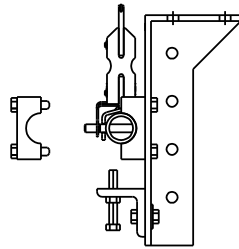

Fig. 5

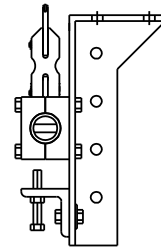

Fig. 6

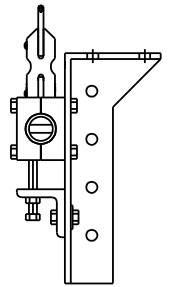

Fig. 7

Test run the conveyor. If chattering occurs, loosen the tube clamp bolts and rotate the blade tip about 5 deg in the direction of belt travel.

MAINTENANCE

After one day
of operation:

- 1.)** Inspect the cleaner for proper belt cleaning and operation.

Weekly:

- 1.)** Frequent inspection is the key to proper belt cleaning and easy Scraper servicing. Weekly inspections are recommended, but actual service frequency may vary widely depending on various plant operating conditions.
- 2.)** Wash the entire cleaner regularly to prevent excessive buildup. If material tends to accumulate on the Scraper Assembly then possible scraper relocation may be in order.
- 3.)** Carefully inspect the wear tips of the cleaner blades. Make sure blades are not chipped or worn out. (Replace when necessary)
- 4.)** Inspect the belt surfaces and edges for cracks, splits, tears, holes or any other worn or damaged condition occurring on the surfaces or edges of the belt itself. If necessary make repairs to the belt.

REPLACEMENT AND RE-TENSIONING OF CLEANER BLADES

- 1.)** Lower mounting tube to disengage the cleaner blades from the belt. By loosening the tube clamp bolts against the mounting bracket, then lowering the adjustment bolt.
- 2.)** Then remove the locking pin and slide out the blade holder with the cushions and blades attached.
- 3.)** Loosen and remove the bolts and nuts holding the blades onto the TORO cushions.
- 4.)** Remove the worn blades and discard.
- 5.)** Position new blades on the TORO cushions and reinstall the nuts and bolts to hold the blades evenly across the cleaner edge.
- 6.)** Reinstall the blade holder with blades in place and tension according to directions

TROUBLESHOOTING

PROBLEM	SOLUTION
<i>Excess vibration of the scraper.</i>	Make certain all bolts are tight. If belt is non-reversing, rotate the blade about 5 degrees in the direction of the belt movement.
<i>Excess carryback.</i>	Check for proper Scraper tension. Put additional tension on cleaner.
<i>Check for wear on the cleaning tips.</i>	Check thickness of carryback. If the cleaner must remove more than about 1/8" of material then a precleaner may be needed.
<i>Excess belt movement, cupping</i>	Install a hold down roller to stabilize the belt surface.
<i>Unable to tension scraper properly, belt moves away from blades.</i>	Install a hold down roller to reduce sag of the belt when tensioning.
<i>Frozen material on scraper.</i>	Place heaters near scraper to melt frozen material. (Use caution not to burn belt or cleaner)

Information

Key	Description	Part Number
1	Bolt-Up Tensioner	M-NW3-BU
2	Mounting Tube	ASG-RBMT-(BW) [BW] = Belt Width
3	Rubber Cushion	ASG-CUS-TORO-6
11	Urethane Blade	ASG-CUS-TORO-UB
11a	Blade Tip TC	ASG-BLD-TORO-6-TC-C (Requires Rubber Cushion)
11b	Blade Tip AR	ASG-BLD-TORO-6-AR (Requires Rubber Cushion)
12	Blade Holder	ASG-RBBH-(BW)

Call your ASGCO Distributor for any questions or replacement parts