



# E-Z MOUNT SKIRTING SYSTEM

## INSTALLATION, OPERATION & MAINTENANCE INSTRUCTIONS



Check us out at  
[www.asgco.com](http://www.asgco.com)

Customer Service  
**800-344-4000**



24 Hour Emergency  
Service and Parts  
610-821-0210



ASGCO Mfg., Inc.  
301 Gordon Street  
Allentown, PA 18102  
610-821-0216  
FAX 610-778-8991

## Important Safety Notice

Always observe the basic rules of safety when working with any conveyor system. To avoid injury and equipment damage, be sure that all controls to the conveyor are locked out and the power source is disconnected at all times during installation.

## Overall View

If mounting structure is not available or worn, additional skirt steel may have to be added. Make sure that the existing skirt is approximately 2/3 Belt Width (Standard). On narrow belts such as 24" and 30" make sure that the belt is tracking properly or the belt may run out from under the skirting.

1. Mounting channel B22, B12 or B22B as shown below.
2. E-Z Mount Sealing Compound

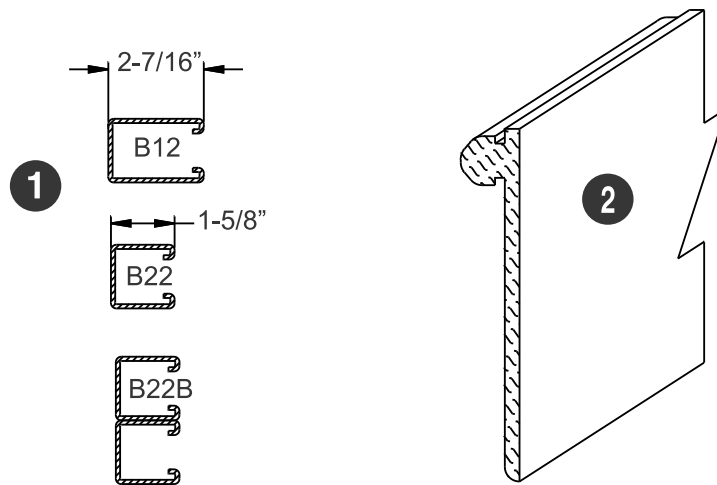

Weld the channel supplied with your system to the existing steel skirt structure at the dimension shown in either illustration A, B, or C. Then lay the sealing compound on the belt with the nub toward the channel. Using a hammer pound the compound into the channel opening. If the section of skirting is less than 20' the E-Z Mount compound can be slid in from one end.

---

**Tip:** Lubricate the rubber with soap, WD 40, or some other suitable material.

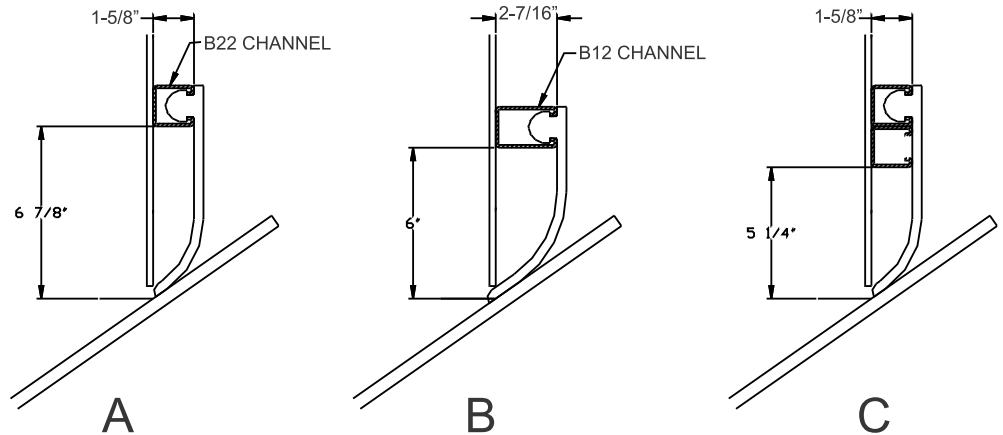

---

*If you were supplied with the B22B type channel, adjustment for wear is accomplished as shown below. Simply move the sealing compound from the top channel to the lower channel when the initial installation is hanging straight down, as shown.*

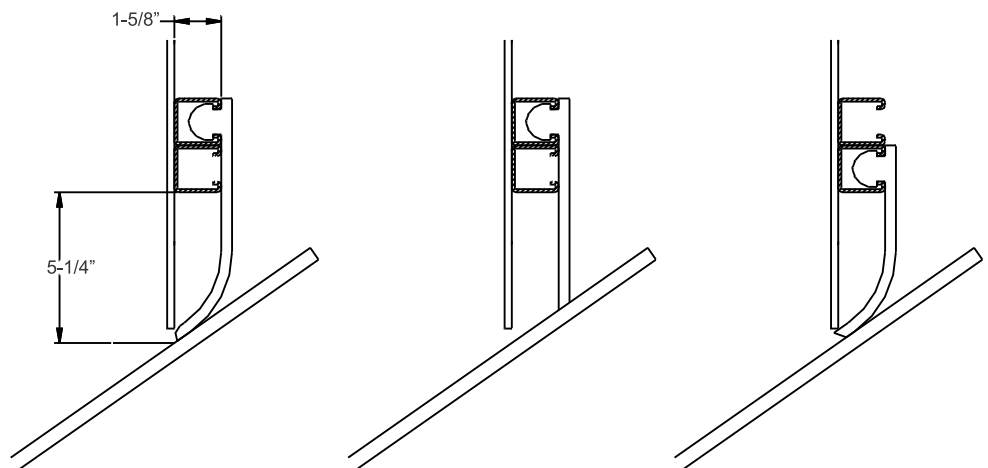

*Test run the conveyor. If squealing or smoking occurs, put water, dust or some material onto the belt to provide some initial lubrication.*

---

## Information

Key	Description	Part Number
1	E-Z Mount 8" Rubber w/Double Channel	AEM-EZM-0958-SCH2
2	E-Z Mount 8" Rubber w/Squared Ends	AEM-EZM-0958-S

*Call your ASGCO Distributor for any questions or replacement parts*

## TROUBLE SHOOTING

<b>PROBLEM</b>	<b>SOLUTION</b>
<i>Squealing or smoking rubber</i>	Put water, dust or some other lubricant on the belt.
<i>Excessive leakage at skirt.</i>	Belt deflects downward between the troughing idlers. Install slider under the skirting area to prevent sag in the belt.
	Skirting is hanging straight down, replace worn skirting  Material too coarse and sharp for skirting that lays on the belt.
<i>Skirting “flops” to the outside of the belt.</i>	Belt too narrow, edges worn away.  Chute too wide not standard 2/3 Belt Width, Narrow chute feeding the belt.  Belt mis-tracking, train belt or add training rollers.

---

## MAINTENANCE

### **After one day of operation:**

- 1.) Inspect the skirt for leakage.

---

### **Weekly:**

- 1.) Inspect the skirt for leakage and wear.

---

## REPLACEMENT OF SKIRT SEAL RUBBER

1. Starting at one end pull the skirting compound out of the channel.
- 2.) If the B22B channel was used, move the nub to the lower channel.
- 3.) If single channel or the lower channel has been used then discard worn out skirt and replace with new material..