



RAZOR-BACK[®]

with Spring-Shoc[™] Tensioner System

INSTALLATION, OPERATION & MAINTENANCE INSTRUCTIONS

PUSH-UP

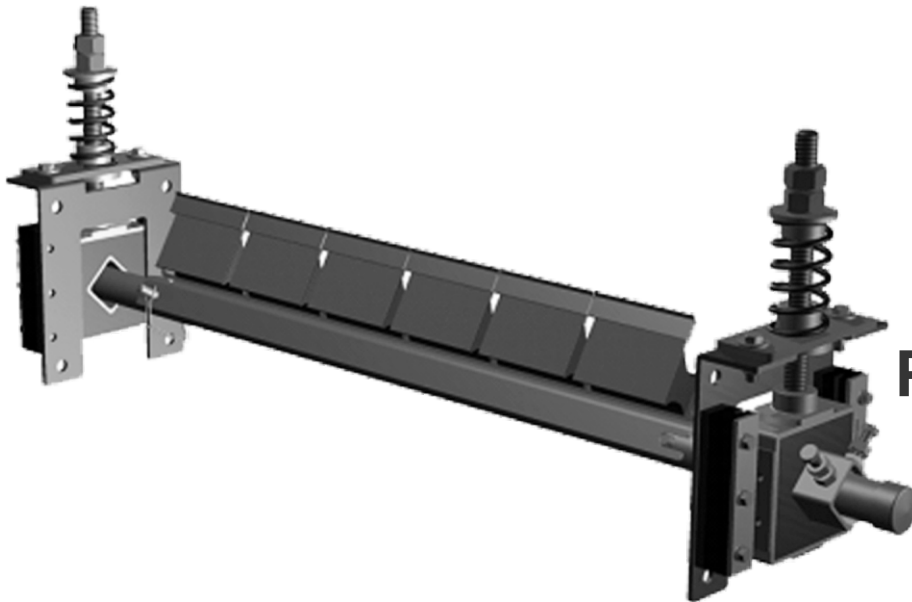
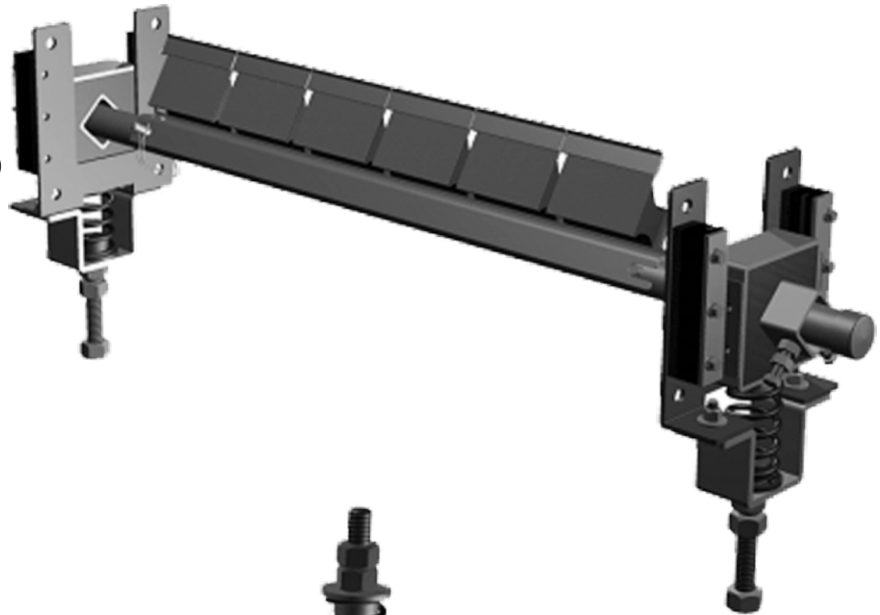

PULL-UP

Check us out at
www.asgco.com

Customer Service
800-344-4000



24 Hour Emergency
Service and Parts
610-821-0210

ASGCO Mfg., Inc.
301 Gordon Street
Allentown, PA 18102
610-821-0216
FAX: 610-778-8991

Important Safety Notice

Always observe the basic rules of safety when working with any conveyor system. To avoid injury and equipment damage, be sure that all controls to the conveyor are locked out and the power source is disconnected at all times during installation and maintenance.

Overall View

If mounting structure is not available, additional steel may have to be added. *Note: Excess mounting tube may be trimmed after installation. In addition two mounting strips will be shipped to you in the event you have ordered the urethane blade Razor-Back unit.*

Components Diagram

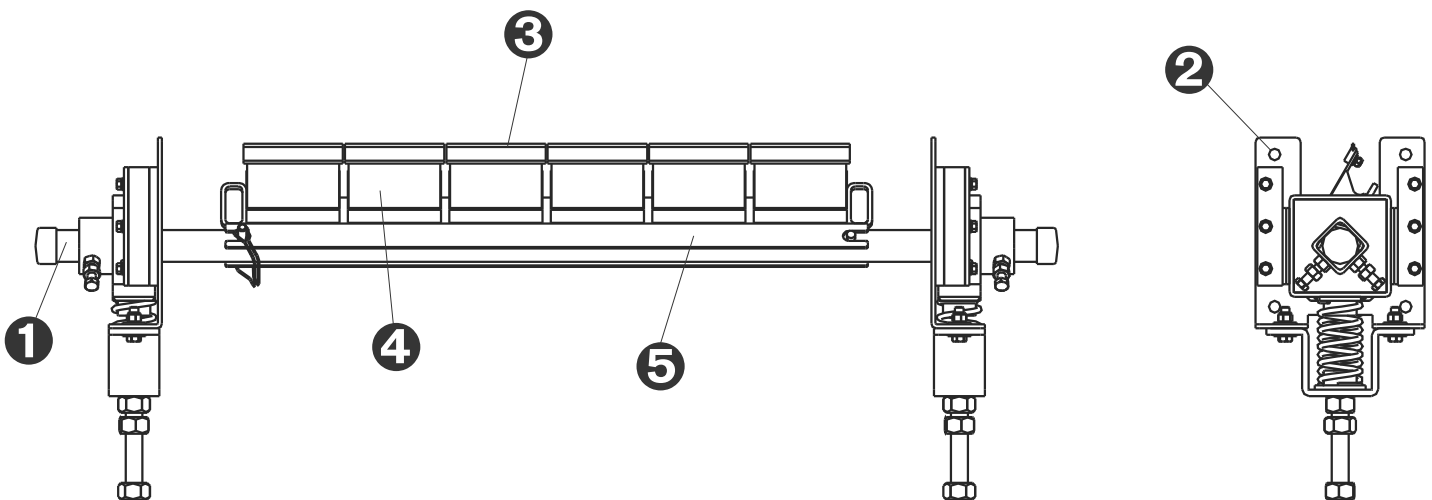

1. Razor-Back Mounting Tube
2. Spring-Shoc Tensioner
(Push-Up Position)
3. Razor-Back Blade Tip (F-Tip, C-Tip, V-Tip,
MDX V-Tip, MDX C-Tip, Urethane)
4. Razor-Back Blade 6" Rubber Cushion
5. Cartridge Blade Holder

Spring-Shoc Tensioner Components

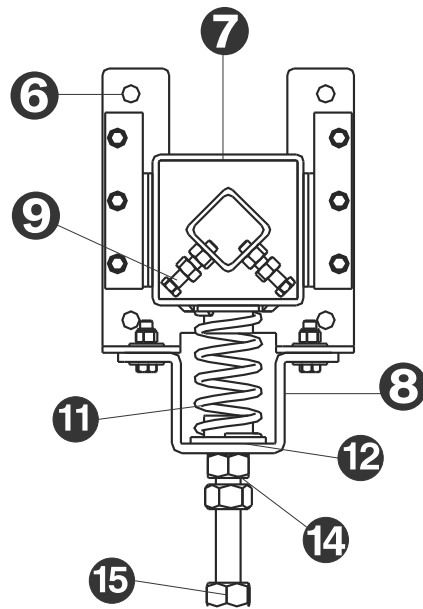

PUSH-UP Position

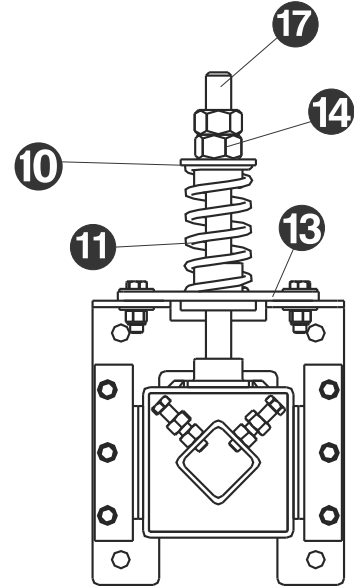

PULL-UP Position

6. Mounting Bracket
7. Slide Block
8. Push-up Bracket
9. Set Screws
10. Thru-Hole Spring Bushing
11. Compression Spring (Light Duty - Red) (Heavy Duty - Silver)
12. Push-Up Spring Bushing (Half Hole Locator)
13. Pull-up Bracket
14. ACME Lock Down Nut
15. Push-Up ACME Adjustment Bolt

Determine Cleaner Mounting Location

The Razor-Back is a secondary belt cleaner and as such should be located on the return side of the belt after the belt leaves contact with the head pulley as shown below. Preferably it should be located within the confines of the head or dribble chute.

The Duo-Spring Tensioner can be mounted in either the Pull-Up Position or the Push-Up Position depending on the structure that the tensioner bracket will be mounted on and the surrounding components. See Figure 1.

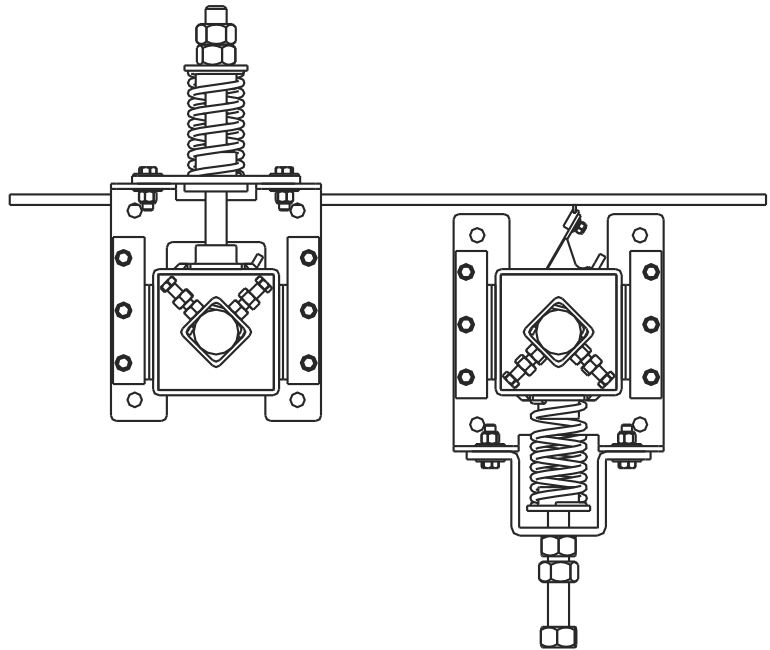

Figure 1. Typical Cleaner Mounting Locations

The recommended clearance from the belt tangent point off the head pulley to the tip of the cleaner blade is 4 inches (100 mm).

The recommended clearance between the tip of the cleaning blade and a snub pulley is 5 ½ inches (140 mm).

Locate Mounting Bracket

The Mounting Bracket should be attached to the chute wall or conveyor structure using the four mounting holes and $\frac{1}{2}$ -13 UNC x 2 $\frac{1}{2}$ inch hex head bolts, see Figure 2 for mounting hole dimensions.

The Mounting Brackets can also be welded in place. (Note: the Mounting Brackets are a Powder Coated Mild Steel)

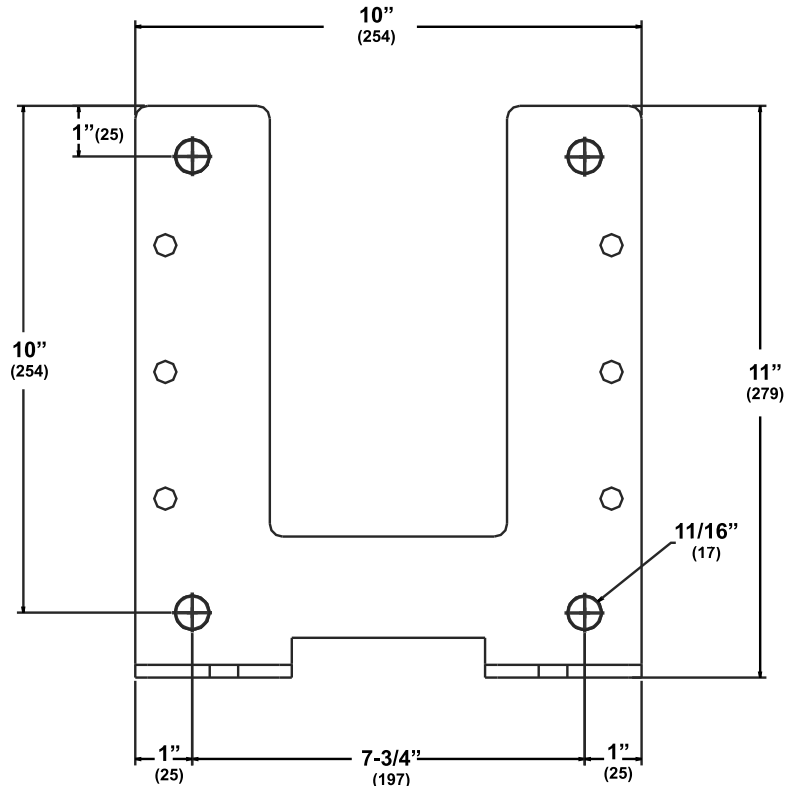

Figure 2. Mounting Bracket Dimensions

- To determine the desired location of the mounting brackets, locate the bottom edge of the belt. Then depending on spatial constraints, then choose between **Push-Up Position** or **Pull-Up Position**.

A. Push-Up Position

The center of the top mounting holes of the Mounting Bracket should be located MOA inches below the bottom edge of the belt (**MOA** Mounting Bracket Offset Push-Up Position). Refer to Figure 3. Table 1 indicates the MOA distance for each type of Razor-Back Blade Tip.

B. Pull-Up Position

The top center of the top mounting holes of the Mounting Bracket should be located MOB inches above the bottom edge of the belt (**MOB** Mounting Bracket Offset Pull-Up Position). Refer to Figure 3. Table 1 indicates the MOB distance for each type of Razor-Back Blade Tip.

Table 1: Mounting Bracket Offset

Blade Tip	MOA	MOB
V-Tip	Flush	3/4" [19mm]
C-Tip	Flush	1-1/8" [29mm]
F-Tip	3/16" [5mm]	1/2" [13mm]
MDX V-Tip	1/2" [13mm]	3/16" [5mm]
MDX C-Tip	Flush	1-1/16" [27]

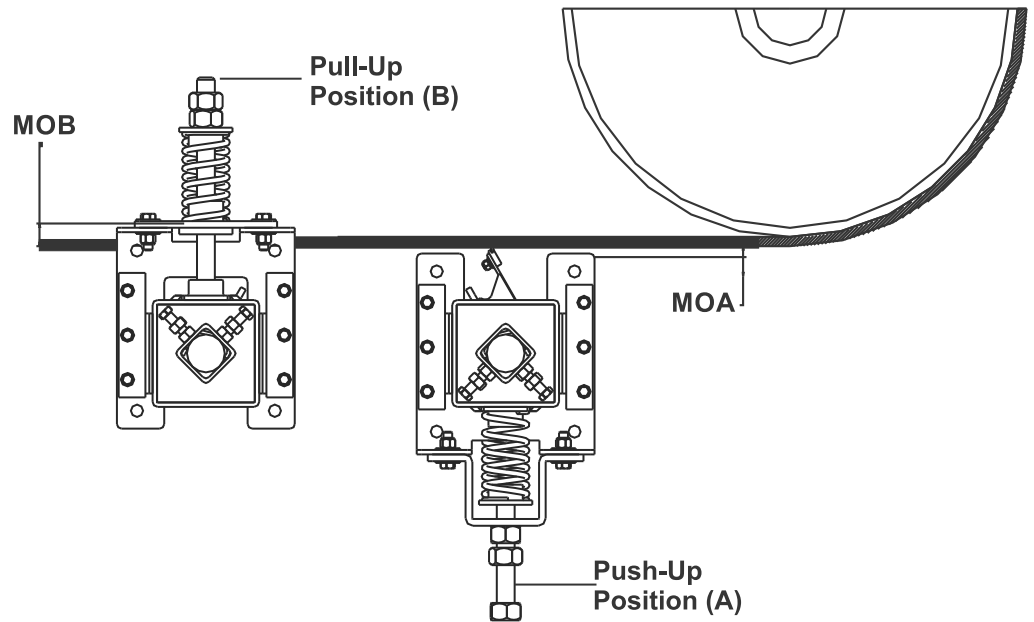

Figure 3: Mounting Bracket Height Locations for Pull-Up & Push-Up Positions

- With the Mounting Bracket held in place, mark the location of the four mounting holes. Then using a 9/16 inch drill bit or a torch, cut the four bolt holes into the conveyor chute or frame work. As noted above the Mounting Bracket can also be welded in place.

If the Mounting Brackets are to be mounted to an enclosed chute, an elongated hole will have to be cut into the chute wall to allow the blades and the mounting tube to pass through from one side of the conveyor to the other. See Figure 4.

Cut Chute Openings

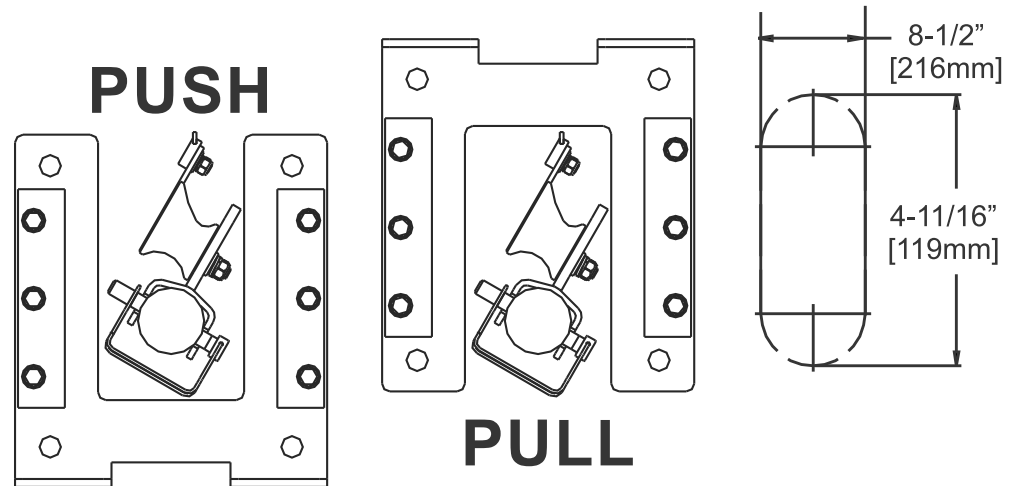

Figure 4. Chute Openings Dimensions

Spring-Shoc Tensioner Assembly Assembly of the Duo-Spring Tensioner is shown in Figure 5. The left image is the Tensioner in Pull-Up Position and the right image is for the Tensioner in Push-Up Position. All the parts are provided to assemble the tensioner in either position. Duo-Spring position specific hardware is shown in Figure 5.

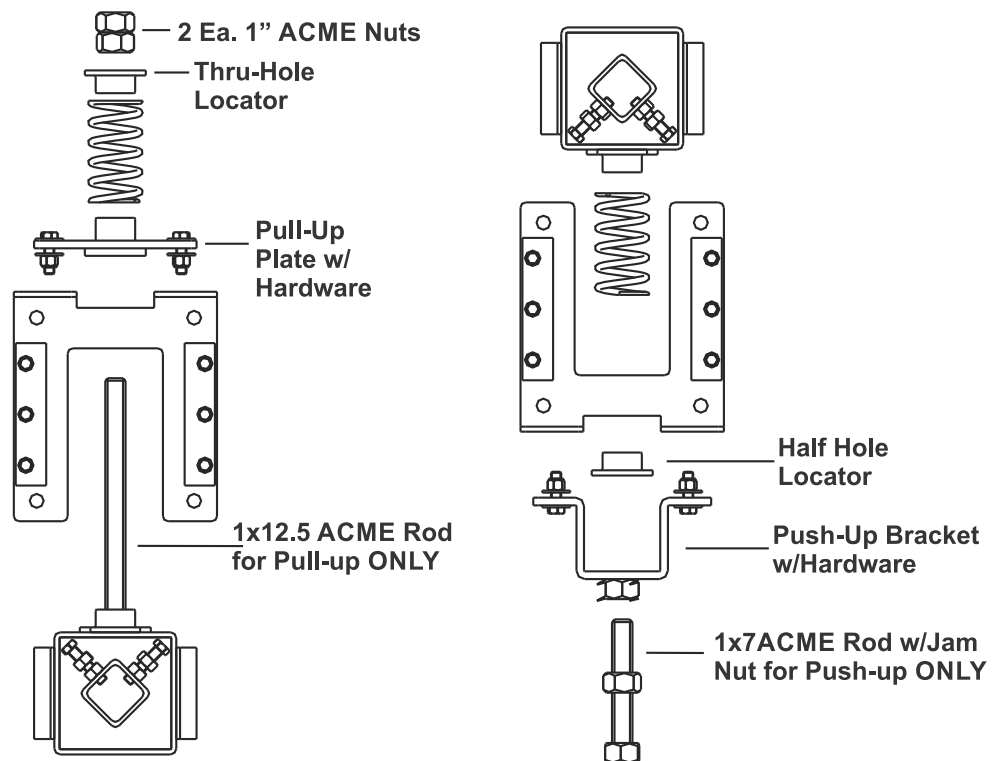

Figure 5. Duo-Spring Tensioner Assembly: Pull-Up (left) and Push-Up (right) Tensioners

Blade Positioning and Alignment

With the Mounting Tube and Blade Holder in position, align the Blade Tips so that they are perpendicular to the belt. Center the blade on the belt by sliding the support tube in the support tube collars. Firmly tighten the Square Head Set Screws (to 65-70 ft-lbs.) on the Slide Block collar to affix the rotation and translation of the Mounting Tube.

Raise the Slide Blocks by evenly turning the adjustment bolts until the blade just contacts the belt. Check that the blade is evenly contacting the belt along the entire length of the blade. Once uniform blade/belt contact has been achieved, evenly raise the Slide Blocks causing the spring to load. Continue to tighten until sufficient upward force (blade pressure) has been achieved see Table 2 below. Spring Height (H) is the suggested tension starting point See Figure 9. Firmly tighten the lock nut on the two adjustment bolts. It may be possible that there is enough play in the belt that there can be enough downward force via belt weight so that compressing the spring may not be necessary.

Table 2. Spring-Shoc Tensioner, Tension Chart

Belt Width	Spring Height (H)	Spring Compression
18	4 3/4 [120mm]	1/4 [6mm]
24	4 11/16 [119mm]	5/16 [7mm]
30	4 5/8 [117mm]	3/8 [9mm]
36	4 9/16 [115mm]	7/16 [11mm]
42	4 1/2 [114mm]	1/2 [12mm]
48	4 11/16 [119mm]	5/16 [7mm]
54	4 5/8 [117mm]	3/8 [9mm]
60	4 9/16 [115mm]	7/16 [11mm]
72	4 1/2 [114mm]	1/2 [12mm]
84	4 7/16 [112mm]	9/16 [14mm]
96	4 3/8 [111mm]	5/8 [15mm]

Note: Belt Widths of 48 inches and above use the Heavy Duty Silver Spring.

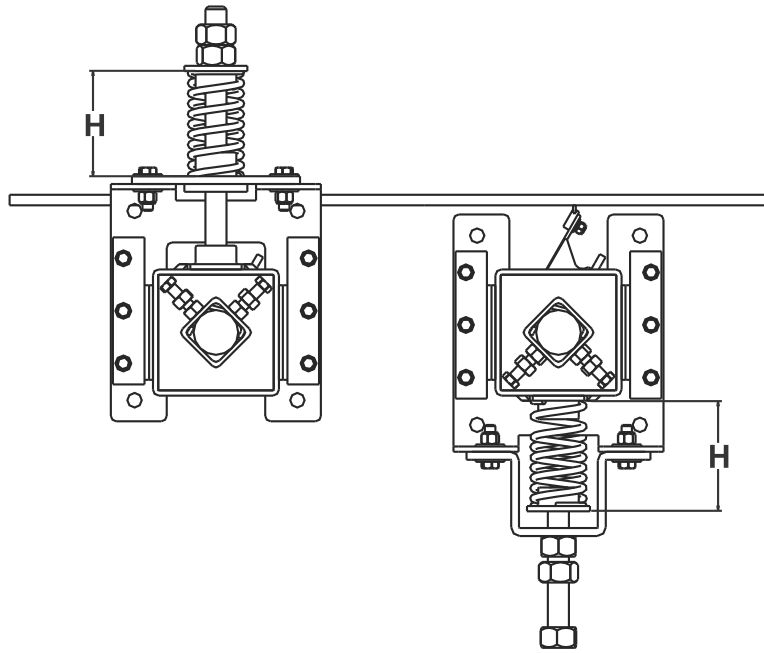

Spring Height (H) Measurement Location

Test run the conveyor.

If chattering or vibration of the blade occurs, try increasing the Spring compression or rotating the Blade Tips slightly in the direction of belt travel (in 5 degree increments).

OPERATION & MAINTENANCE

After one day of operation:

1. Inspect the cleaner for proper belt cleaning and operation.

Weekly:

1. Frequent inspection is the key to proper belt cleaning and easy Scraper servicing. Weekly inspections are recommended, but actual service frequency may vary widely depending on various plant operating conditions.
2. Wash the entire cleaner regularly to prevent excessive buildup. If material tends to accumulate on the Scraper Assembly then possible scraper relocation may be in order.
3. Carefully inspect the wear tips of the cleaner blades. Make sure blades are not chipped or worn out.
4. Inspect the belt surfaces and edges for cracks, splits, tears, holes or any other worn or damaged condition occurring on the surfaces or edges of the belt itself. If necessary make repairs to the belt.

REPLACEMENT AND RE-TENSIONING OF CLEANING BLADES

1. Lower the Mounting Tube by loosening the Adjustment Bolt on both sides of the cleaner. This will disengage the cleaner blades from the belt.
2. To remove the Blade Holder from the Mounting Tube, pull the Locking Pin from the Mounting Tube. Then slide the Blade Holder over and up to remove the Cartridge with Cushions and Blades attached.
3. Loosen and remove the nuts and washers holding the Blade Tips onto the Cushions.
4. Remove the worn Blade Tips and discard.
5. Position new Blade Tips on the Razor-Back Cushions and reinstall the nuts and washers to hold the Blade Tips on the Razor-Back Cushions, making sure the Blade Tips are flush along the leading edge.
6. Reinstall the Blade Holder with Cushions and New Blade Tips to the Mounting Tube and re-engage Blade Tips according to directions.

Information

Key	Description	Part Number
1	Razor-Back Mounting Tube	ASG-RBMT - (BW) [BW] = Belt Width
2	Blade Holder	ASG-RBBH - (BW)
4	F-Tip	ASG-BLD-RZ-6-AR
4a	C-TIP	ASG-BLD-NW3-6-TC-C
4b	V-TIP	ASG-BLD-RZ-6-TC
4c	MDX V-TIP	ASG-MDX-BLD-RZ-6-TC
4d	MDX C-TIP	ASG-MDX-BLD-NW3-6-TC-C-MDX
5	Cushion 6" AR RZ	ASG-CUS-RZ-6C
6	Spring-Shoc	Tensioner
	12"-42" BW	M-ASG-RB-ST-SEC-1242
	48"-84"	M-ASG-RB-ST-SEC-4896

Call your ASGCO Distributor for any questions or replacement parts

TROUBLESHOOTING

PROBLEM	SOLUTION
<i>Excess vibration of the scraper.</i>	Make certain all bolts are tight. If belt is non-reversing, rotate the blade about 5 degrees in the direction of the belt movement.
<i>Excess carryback.</i>	Check for proper Scraper tension. Put additional tension on cleaner.
<i>Excess belt movement, cupping</i>	Install a hold down roller to stabilize the belt surface.
<i>Unable to tension scraper properly, belt moves away from blades.</i>	Install a hold down roller to reduce sag of the belt when tensioning.
<i>Frozen material on scraper.</i>	Place heaters near scraper to melt frozen material. (Use caution not to burn belt or cleaner)