

POWERTURN DATA SHEET

In order for us to serve you better by manufacturing a power turn belt correctly, please answer the following questions as accurately and completely as possible. Please specify units of measure (in/mm). If circumstance allows, please call our Customer Service Department to obtain an RGA# in order to send us the power turn belt you are now using for evaluation. This can speed up the process and ensure a more precisely manufactured belt.

- 1) Type of belt required _____
- 2) Degree of power turn belt required (cc _____°)
- 3) Circumference of the outer edge _____ of the inner edge _____
- 4) Outside radius (A) _____
- 5) Inside radius (C) _____
- 6) Belt width (E) _____
- 7) Type, number and radius of buttons/eyelets/grommets (D) _____
- 8) Radius of buttons/eyelets/grommets center line (B) _____
- 9) Number of holes required _____
- 10) Reinforcing band required on outer circumference yes/no _____ Width of Reinf _____
- 11) Machine manufacturer, if known _____

Comments:

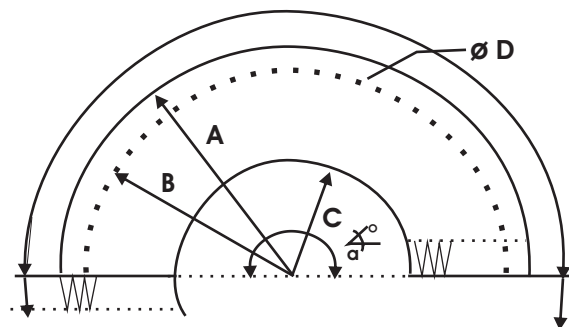

ILLUSTRATION OF 90 DEG. BELT BEFORE MAKING ENDLESS.