

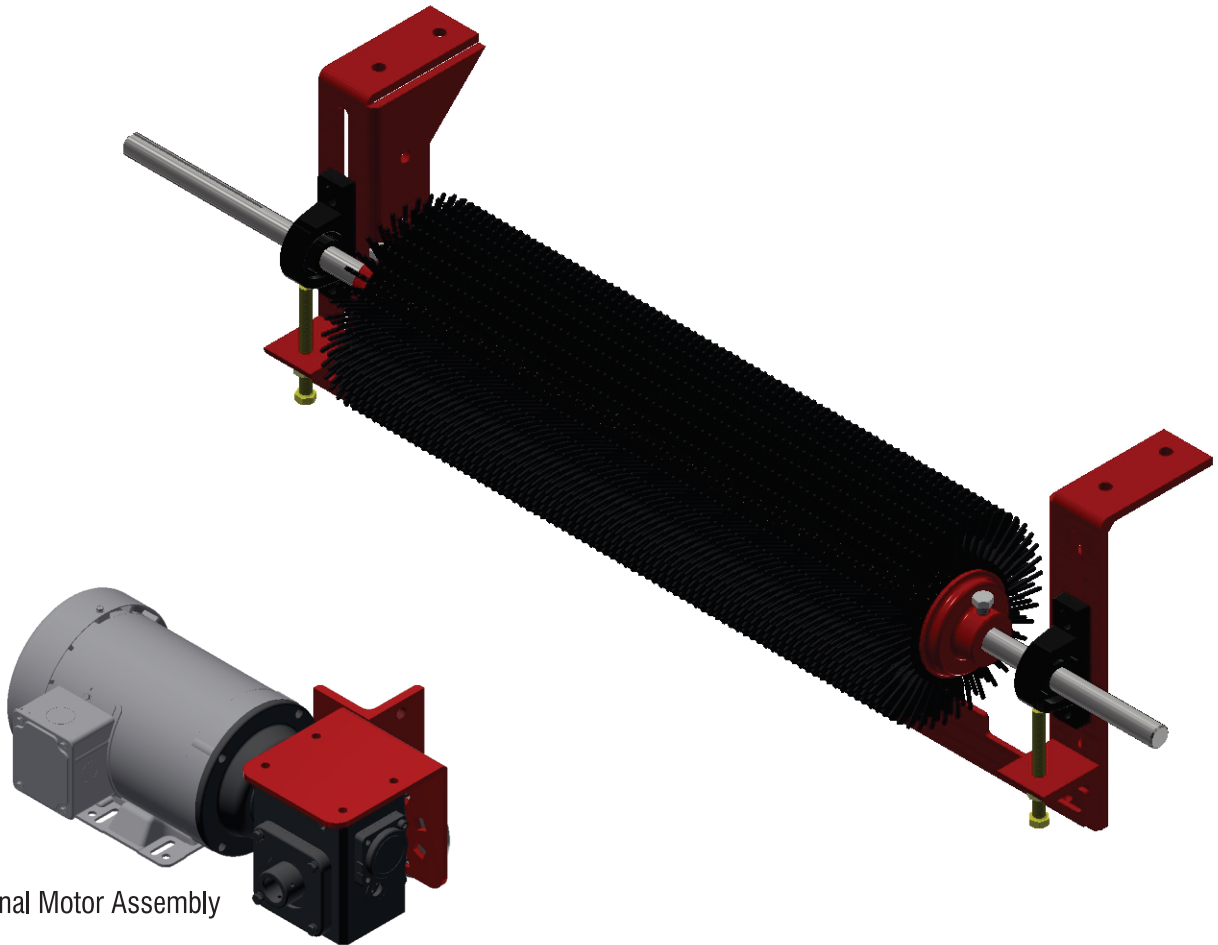

CHEVRON BRUSH CLEANER™

INSTALLATION, OPERATION & MAINTENANCE INSTRUCTIONS



Optional Motor Assembly

Check us out at
www.asgco.com

Customer Service
800-344-4000



24 Hour Emergency
Service and Parts
610-821-0210

ASGCO Mfg., Inc.
301 Gordon Street
Allentown, PA 18102
610-821-0216
FAX 610-778-8991

Important Safety Notice

Always observe the basic rules of safety when working with any conveyor system. To avoid injury and equipment damage, be sure that all controls to the conveyor are locked out and the power source is disconnected at all times during installation.

Installation Tools

In addition to the items provided by ASGCO, the following will be needed to install the Chevron Cleaner:

1. Grinder
2. Drill with 9/16" bits
3. Cutting or burning equipment
4. Adjustable wrench, ratchet, sockets
5. Tape measure
6. Carpenter's square
7. Straight edge
8. Allen wrench set

Selecting a location for the Chevron

The Chevron Brush Cleaner™ assembly is designed to remove the fine carryback material. When choosing a mounting location for the brush, it is important to consider the space available. The brush assembly can be mounted on the arc of a pulley or any section of the belt that is flat and tight.

**Min-Max Belt Speed:
300 to 700 FPM**

**No minimum belt speed
to 700 FPM Max with
Motor Option**

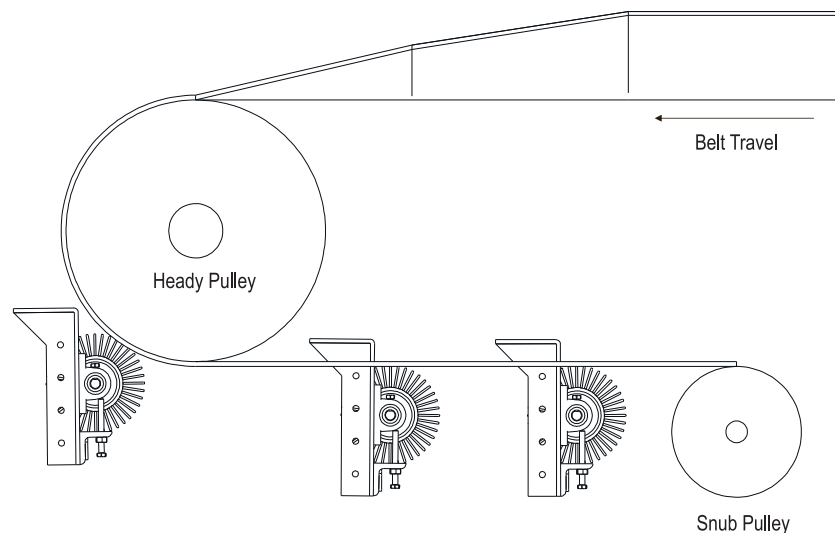

Rotary Brush mounted on arc of pulley or flat section of belt

NOTE: *The center point of the last shaft must be at least 14" away from any pulley or idler that is mounted below the belt.*

It is also important that the mounting location is adequate to allow the material to fall back into the main discharge chute or a dribble chute. To ensure sufficient flow of the scraped material down the chute, an unlined chute should have at least a 75° angle (to the horizontal); and UHMW plastic lined chute should have at least a 65° angle (to the horizontal).

BELT TENSION REQUIREMENTS - Because of the unique design of the brush, the shafts must be mounted in a flat, tight area of the belt. The brush cannot operate to its maximum effectiveness on a belt that is loose or cupped.

ADDING IDLERS OR PULLEYS - If a sufficient mounting location cannot be found between the head and snub pulleys, the brush can be placed elsewhere, provided that the proper steps have been taken to prevent the belt from loosening or troughing in the contact area. This can be done by mounting standard return idlers or small pulleys above the belt.

FABRICATING MOUNTING PLATES - If a chute is not present in the desired mounting location, mounting plates can be fabricated to simulate the sides of the chute and provide a mounting base for the Bolts Ups. These plates are made from 1/4" to 3/8" flat stock steel. Once a suitable mounting location has been chosen, the initial setup work can begin. Proceed as follows:

Initial Setup

1. Measure the distance to a point 3-15/16" OR 6-15/16" OR 9-15/16" (YOU WILL BE USING ANY 2 OF THESE DIMENSIONS) down from (perpendicular to) the belt on the chute wall. Mark this point "X".
2. Transfer point "X" to the other side of the chute wall, making sure that the two marks are in the exact same location on both sides. These marks represent the location points of the mounting bracket bolt holes. Keep in mind that they must be at least 14" away from any pulleys or idlers mounted below the returning belt. **Please see illustration below.**

Chevron Brush Cleaner™ Setup Scale 1/3

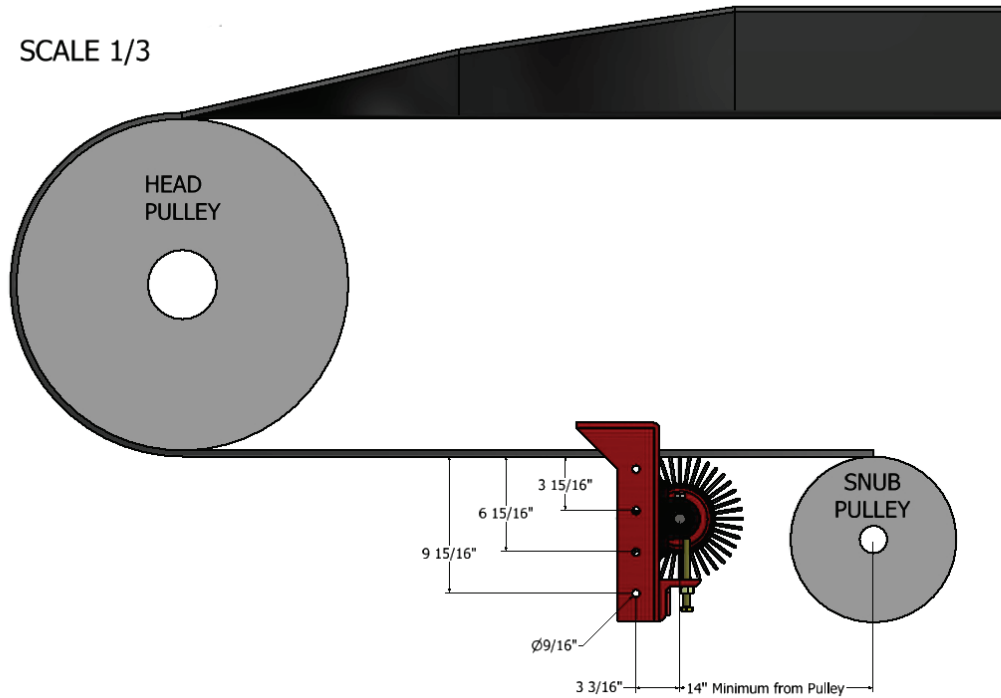

3. Burn or drill a 9/16" diameter hole at each of the "X" points on both chute walls.
4. Insert a 1/2" bolt into each of the 9/16" diameter holes. Be sure to insert the bolts from the inside of the chute wall, then place a nut and washer on each bolt from the outside. Only hand tighten the nuts at this time.
5. Tack weld the heads of each of the bolts on both sides of the chute wall.

When all of the bolt heads have been welded, the Bolt Up bracket installation can begin.

1. Install a bolt up mounting bracket on each of the bolts. To do this, remove the nut & washer; slide the bracket into position, then snug up the hardware by hand tightening.
2. Do this to the other Bolt up mounting bracket.
3. Next we will get ready for the chute cutouts.

(SEE ILLUSTRATION)

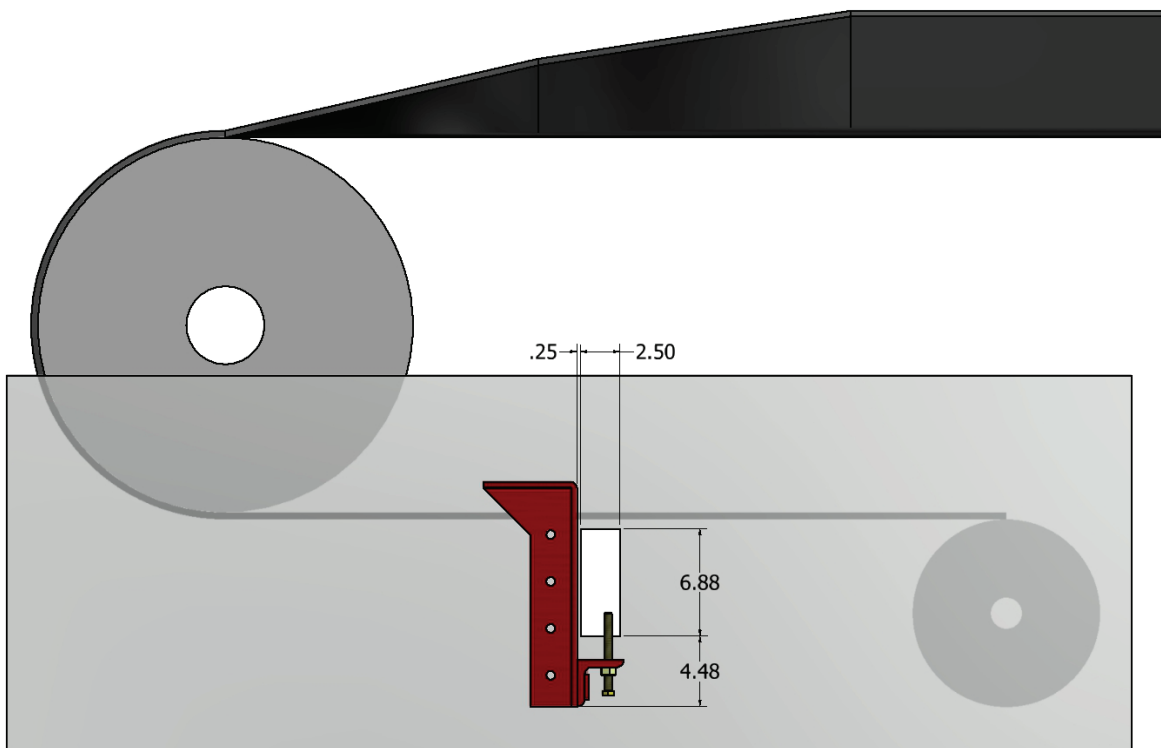

Using a torch or other cutting tool, all the cut-outs need to be made according to the illustration shown above. all dimensions are to be made off of the already installed bolt up brackets.

!WAIT FOR THE CUT OUTS TO COOL DOWN BEFORE PERFORMING THE FINAL STEPS!

From inside the chute, on an angle, slide the brush thru the openings.

Instal the pillow block bearings onto the ends of all shafts being used. Now with the supplied hardware, install the bearings to the bolt up brackets.

The next step is the height adjustment

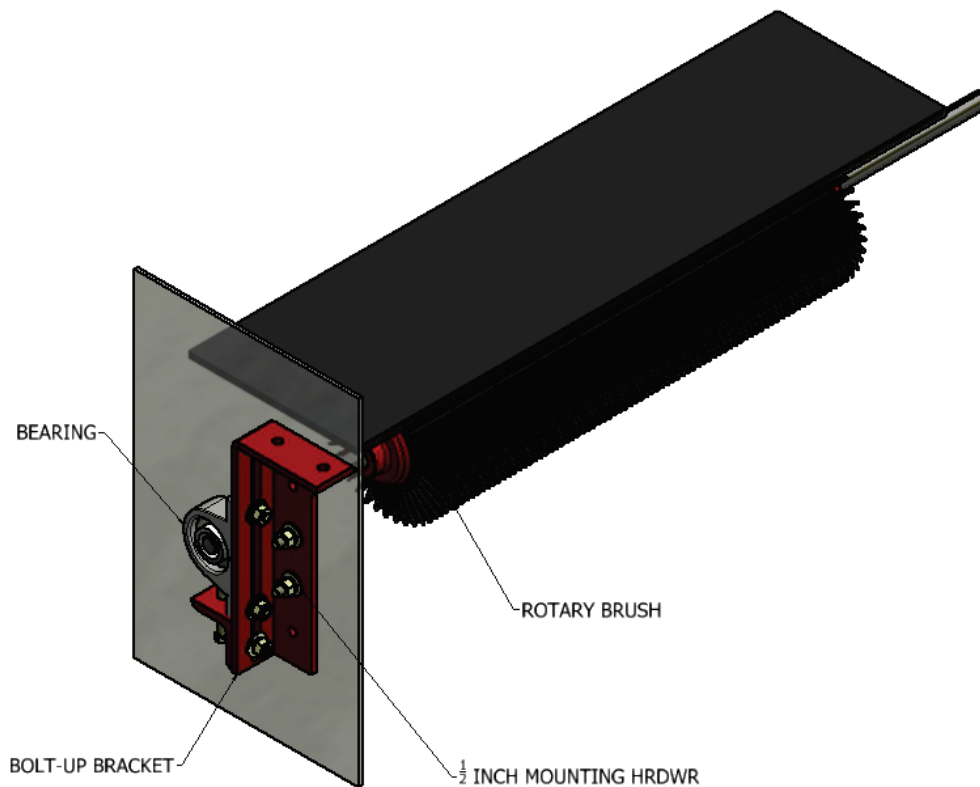

To adjust the brush to its proper cleaning pressure:

Use the supplied adjusting angles and hardware that need to be mounted to the bottom of the bolt up mounting brackets,

Caution: over-adjustment of the brush fingers against the belt will result in premature wear and under-adjustment will result in poor cleaning action.

The starting distance should be 3½ inches from center of shaft to the conveyor belt.

When the Rotary Brush has been properly adjusted, tighten the two nuts with a wrench so that vibration during operation will not cause the adjustment to be altered.

MAINTENANCE

- When used in a 24-hour operation, the Brush must be adjusted every four months.
- Grease the bearing periodically.
- Operation of the conveyor belt without material should be kept to a minimum.

Information

Key	Description	Part Number
1	BRUSH-SHAFT ASSEMBLY NO MOTOR	M-ASG-RBC-XX-NM (XX = BELT WIDTH)
1	BRUSH-SHAFT ASSEMBLY WITH MOTOR	M-ASG-RBC-XX-M (XX = BELT WIDTH)
2	BOLT UP BRACKET	M-NW3-BU
3	1 IN BEARING	ASG-FOD-BR1
3	1 ½ IN BEARING	ASG-FOD-BR2
4	ADJUSTING ANGLE	ASG-NW3-BU-HT-ADJ-SS
5	ALL ½ INCH HARDWARE	ASG-SKMT-AC
6	3 PH 230 / 460 VOLT MOTOR	ASK ASGCO
7	WORM GEAR REDUCER	ASK ASGCO

COMPONENTS DIAGRAM

Non-Motorized

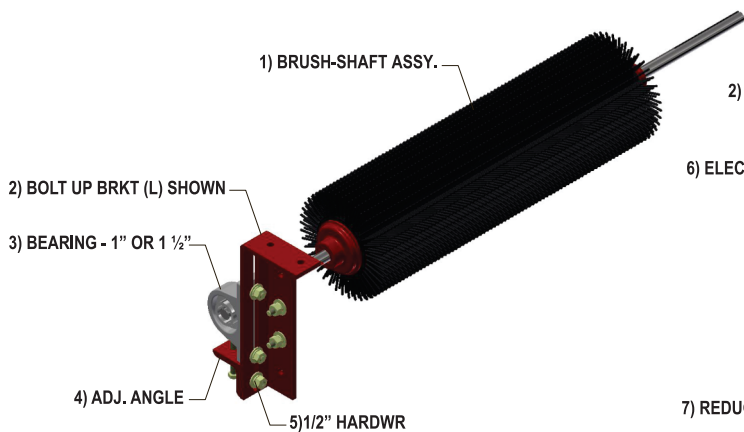

Motorized

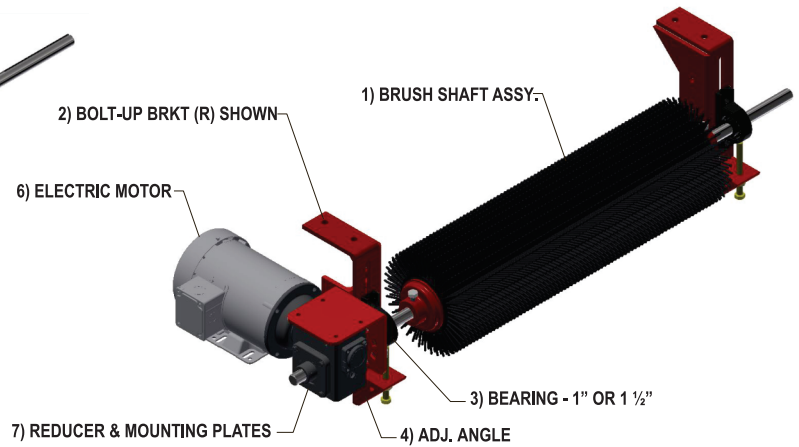

Exploded View

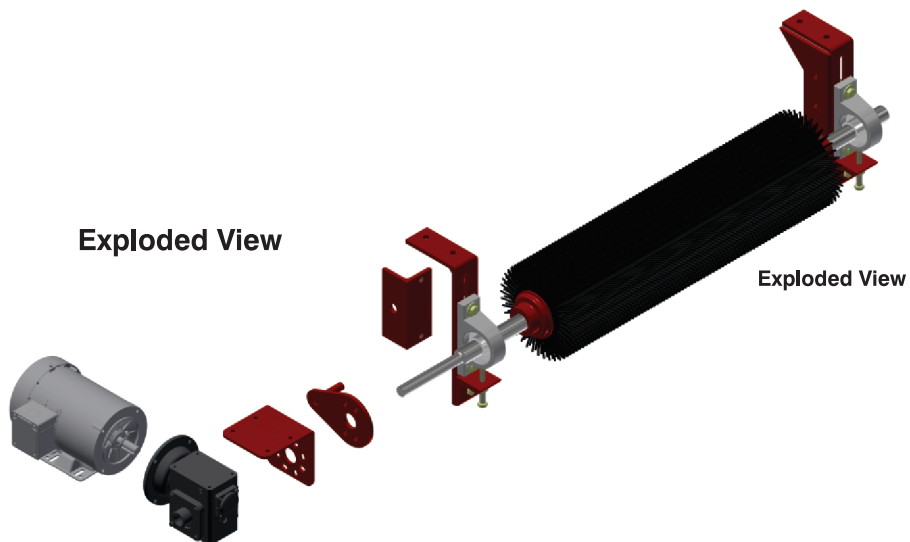

Call your ASGCO® Distributor for any questions or replacement parts. 1-800-344-4000