

# TRU-TRAINER® DUAL V-RETURN IDLER

**ASGCO**  
Complete Conveyor Solutions

The **Tru-Trainer® Dual V-Return Idler** was developed to accommodate the excessive forces encountered with V-Return idler conveyors, systems and structures.

**TWO SEPARATE TAPERED ROLLS** - mounted to the pivot mechanism can be individually replaced as wear occurs

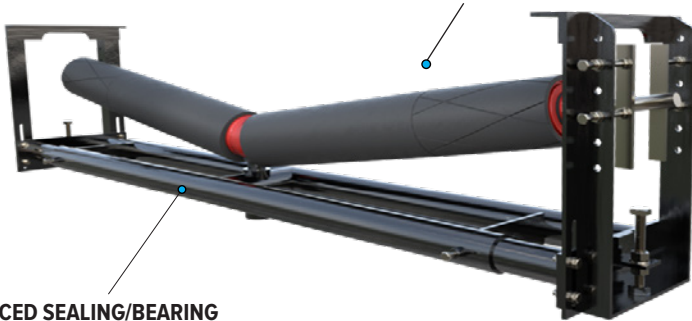

**ENHANCED SEALING/BEARING SYSTEM** • for the most aggressive mining conditions



ALSO AVAILABLE: Tru-Trainer®  
Dual V-Return Urethane Idler

## Features and Benefits

- **Two Separate Tapered Rolls** – are mounted into the pivot mechanism and can be individually replaced as wear occurs.
- **Designed for High Speed/PIW Conveyors** – to operate and last in severe conditions, wet and dry, and aggressive mining conditions.
- **Accommodates Excessive Force** – encountered with wide belts and heavyloads.
- **Enhanced Sealing/Bearing System** – needle thrust and tapered roller bearings and enhanced sealing system for the most aggressive mining conditions.
- **Individual Rollers for Easy Replacement** – separate tapered rolls are mounted onto the pivot mechanism, which can be individually replaced as wear occurs.
- **Available in Urethane (Mine Duty)** – Heavy duty rolls 3/4" polyurethane.



**Need Solutions...to improve efficiency, safety and productivity? ask... ASGCO®**

www.asgco.com | 800.344.4000

@2023 ASGCO® "Complete Conveyor Solutions"

**ASGCO**  
Complete Conveyor Solutions

# TRU-TRAINER® DUAL V-RETURN IDLER

Tru-Trainer® Dual V-Return Idler has an external central pivot mechanism was designed, obviating the need for a single, large drum, and enabling a concentric and balanced rotation to be achieved. This results in extended bearing life and a very fast and effective conveyor tracking system.

## Available in Urethane

Tru-Trainer® Dual V-Return Urethane Idler (Mine Duty) was developed to accommodate the excessive forces encountered with wide belts and heavy loads.

### Tru-Trainer® Dual V-Return Idler & Dual V-Return Urethane Idler Installation Chart

Part Number		Belt Width	A Adjustable Min-Max	B	C	D	E
Dual V-Return Idler	Dual V-Return Urethane Idler						
ASG-TTVR-105-1	ASG-TTVR-105-UE-1	42"	46.25 - 56.50	21.63	23.63	3.44	(-6)-8.62
ASG-TTVR-120-1	ASG-TTVR-120-UE-1	48"	52 - 62.75	24.81	23.63	3.56	(-6)-8.00
ASG-TTVR-135-1	ASG-TTVR-135-UE-1	54"	57.50 - 68.50	27.75	23.63	3.63	(-6)-7.50
ASG-TTVR-150-1	ASG-TTVR-150-UE-1	60"	63.50 - 74.50	30.69	23.63	3.88	(-6)-7.25
ASG-TTVR-165-1	ASG-TTVR-165-UE-1	66"	69.25 - 80	33.69	23.63	4.00	(-6)-6.50
ASG-TTVR-180-1	ASG-TTVR-180-UE-1	72"	75.25 - 86.50	36.63	23.63	4.31	(-6)-6.12
ASG-TTVR-210-1	ASG-TTVR-210-UE-1	84"	87.60-98.43	42.91	23.63	4.80	(-6)-4.92

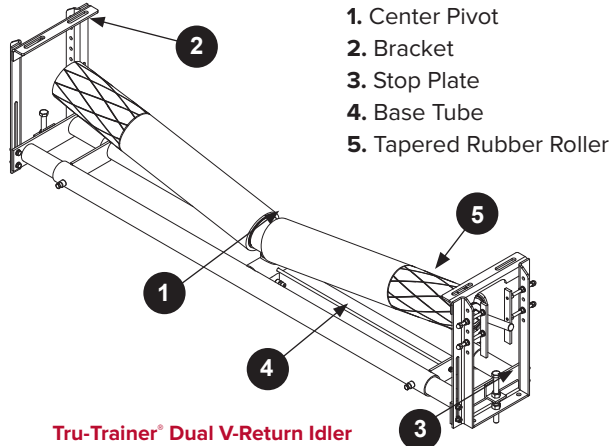
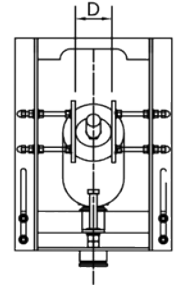
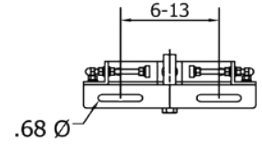

1. Center Pivot
2. Bracket
3. Stop Plate
4. Base Tube
5. Tapered Rubber Roller

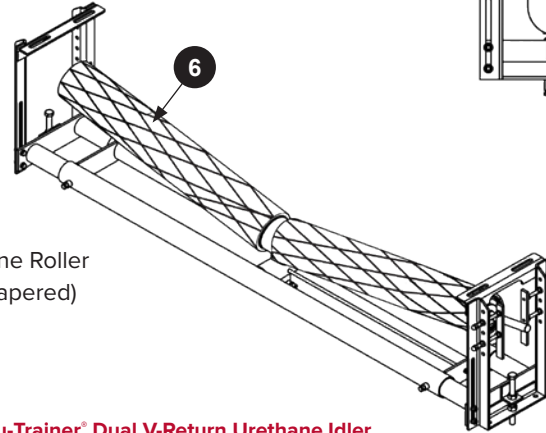

6. Urethane Roller (Fully Tapered)

Tru-Trainer® Dual V-Return Idler

Tru-Trainer® Dual V-Return Urethane Idler

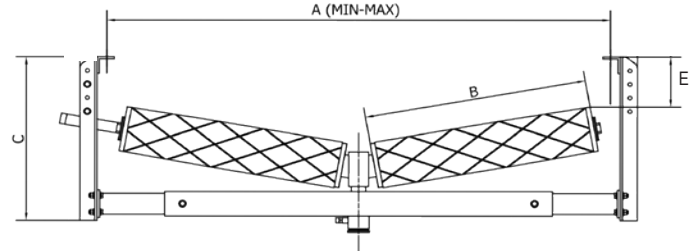
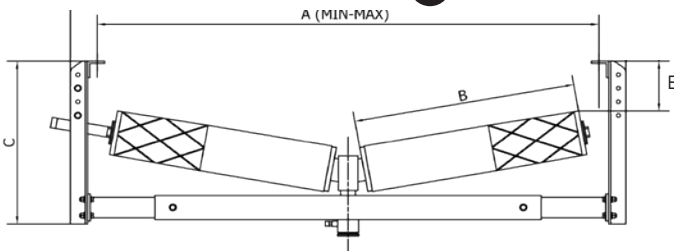

Tru-Trainer® Dual V-Return Idler		
Part Number	Belt Width	
	in	mm
ASG-TTVR-105-1	42	1000
ASG-TTVR-120-1	48	1200
ASG-TTVR-135-1	54	1370
ASG-TTVR-150-1	60	1500
ASG-TTVR-165-1	66	1700
ASG-TTVR-180-1	72	1800
ASG-TTVR-210-1	84	2100

Replacement Roller		
Part Number	Belt Width	
	in	mm
ASG-TTDRIR-135	54	1350
ASG-TTDRIR-150	60	1500
ASG-TTDRIR-165	66	1600
ASG-TTDRIR-180	72	1800
ASG-TTDRIR-200	78	2000
ASG-TTDRIR-210	84	2100
ASG-TTDRIR-220	92	2300
ASG-TTDRIR-240	96	2400

Tru-Trainer® Dual V-Return Urethane Idler		
Part Number	Belt Width	
	in	mm
ASG-TTVR-105-UE-1	42	1000
ASG-TTVR-120-UE-1	48	1200
ASG-TTVR-135-UE-1	54	1370
ASG-TTVR-150-UE-1	60	1500
ASG-TTVR-165-UE-1	66	1700
ASG-TTVR-180-UE-1	72	1800
ASG-TTVR-210-UE-1	84	2100

Urethane Replacement Roller		
Part Number	Belt Width	
	in	mm
ASG-TTDRIR-150-UE	60	1500
ASG-TTDRIR-165-UE	66	1600
ASG-TTDRIR-180-UE	72	1800
ASG-TTDRIR-210-UE	84	2100
ASG-TTDRIR-240-UE	96	2400

Need Solutions...to improve efficiency, safety and productivity? ask... ASGCO®

www.asgco.com | 800.344.4000

@2023 ASGCO® "Complete Conveyor Solutions"

