

ENCLOSED SKIRTING SYSTEM

Effective Skirtboard Sealing System for More-Productive Material Handling



ASGCO's Enclosed Skirt Board Sealing System is a highly effective method of containing material and dust through the conveyor loading points or load zone area. Enclosed Conveyor skirt board systems can be customized with various types of internal skirt board liners, internal dust curtains, external skirting clamps and dust sealing compounds, depending on the application.

INTERNAL LINERS

Vertically Adjustable and easily replaceable

SKIRT LEGS AND WALLS

Vertically and Horizontally Adjustable

DUST CURTAIN

Suppresses and reduces airflow, which helps to contain dust

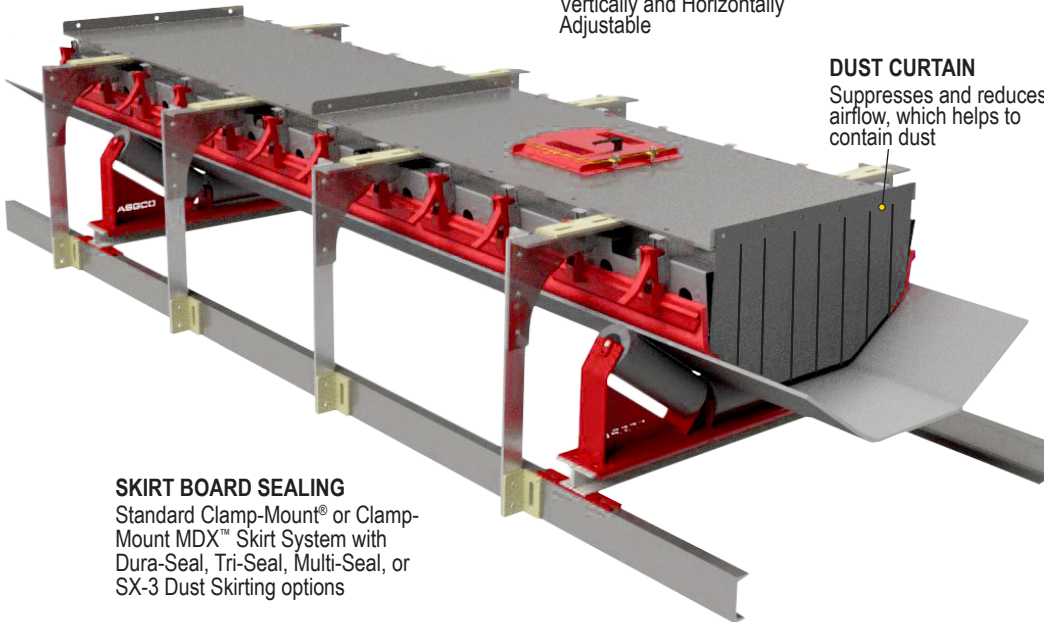

SKIRT BOARD SEALING

Standard Clamp-Mount® or Clamp-Mount MDX™ Skirt System with Dura-Seal, Tri-Seal, Multi-Seal, or SX-3 Dust Skirting options

Features and Benefits

Sealing Options: ASGCO provides a range of internal liners, external skirt clamps and rubber and polyurethane sealing options depending on the application.

Easy Installation: Our skirt legs can be mounted anywhere along your conveyor structure and are vertically adjustable with our horizontally adjustable skirt walls.

Customized: We custom design each Enclosed Skirt Board Sealing System to ensure the highest degree of customer satisfaction.

Easy Maintenance: Internal liners and external skirting are vertically adjustable and easily replaceable.



Need Solutions... to improve efficiency, safety and productivity? **ask... ASGCO®**

www.asgco.com | info@asgco.com | 800.344.400 | 610.821.0216

