

SAFEGUARD® CONVEYOR BELT LIFTER

CONVEYOR BELT LIFTER

The **SafeGuard® Conveyor Belt Lifter** is a patent pending tool developed to make lifting a tensioned conveyor belt easier. Conveyor maintenance is made safer and effortless with the ease and mobility of the lifter allowing for the lifting of all belt troughs, including flat belts.

ASGCO®
Complete Conveyor Solutions

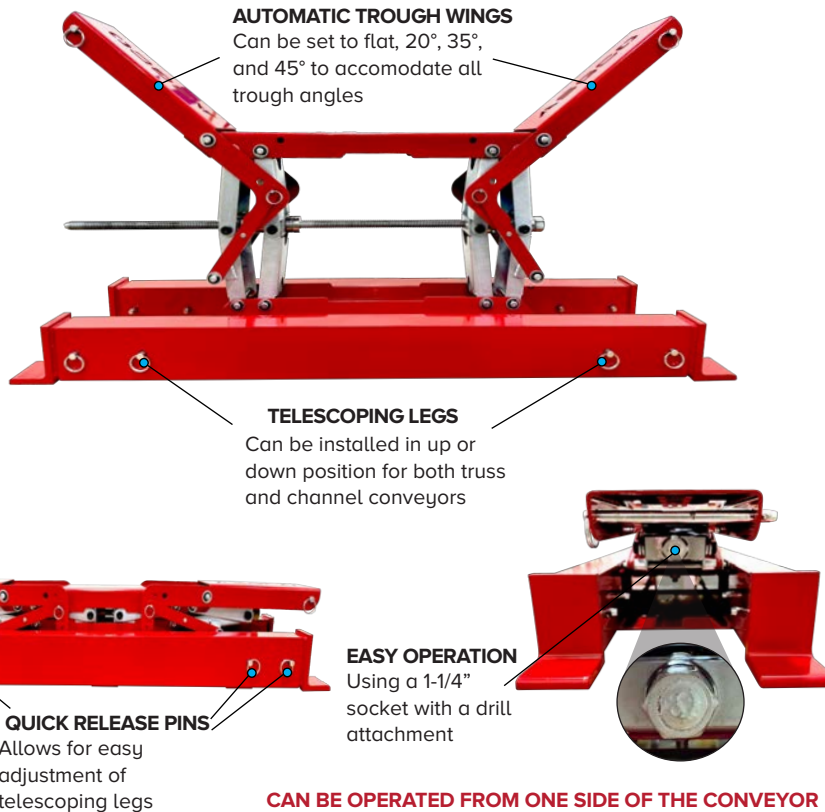

Features and Benefits

- **Easy to use.** The SafeGuard® Conveyor Belt Lifter can be easily operated with a manual ratched or drill.
- **Works on a wide range of conveyors.** The Belt Lifter is for the belt widths 36"-60" (900-1500 mm). Belt can either be lifted flat or in troughed position.
- **Safe.** Features a extendable sturdy dual-rail base and high lift capacities.
- **Easy operation.** Its compact and lightweight design ensures an easy to use operation.
- **Won't damage the belt.** Lift the belt from underneath. Does not clamp onto the belt's edges or cover.

Need Solutions... to improve efficiency, safety and productivity? **ask... ASGCO®**
www.asgco.com | 800.344.4000
@2024 ASGCO® "Complete Conveyor Solutions"

ASGCO®
Complete Conveyor Solutions

SAFEGUARD® CONVEYOR BELT LIFTER

Specifications and Guidelines

Part Number	Belt Width Range		Conveyor Span		Weight		Closed Height		Max Lift Height	
	mm	in	MIN	MAX	kg	lb	mm	in	mm	in
M-ASG-SGBL-3660	900 - 1500	36 - 60	1130 mm (44.5")	1892 mm (74.5")	39.9	88.0	216	8.50	482	19.00

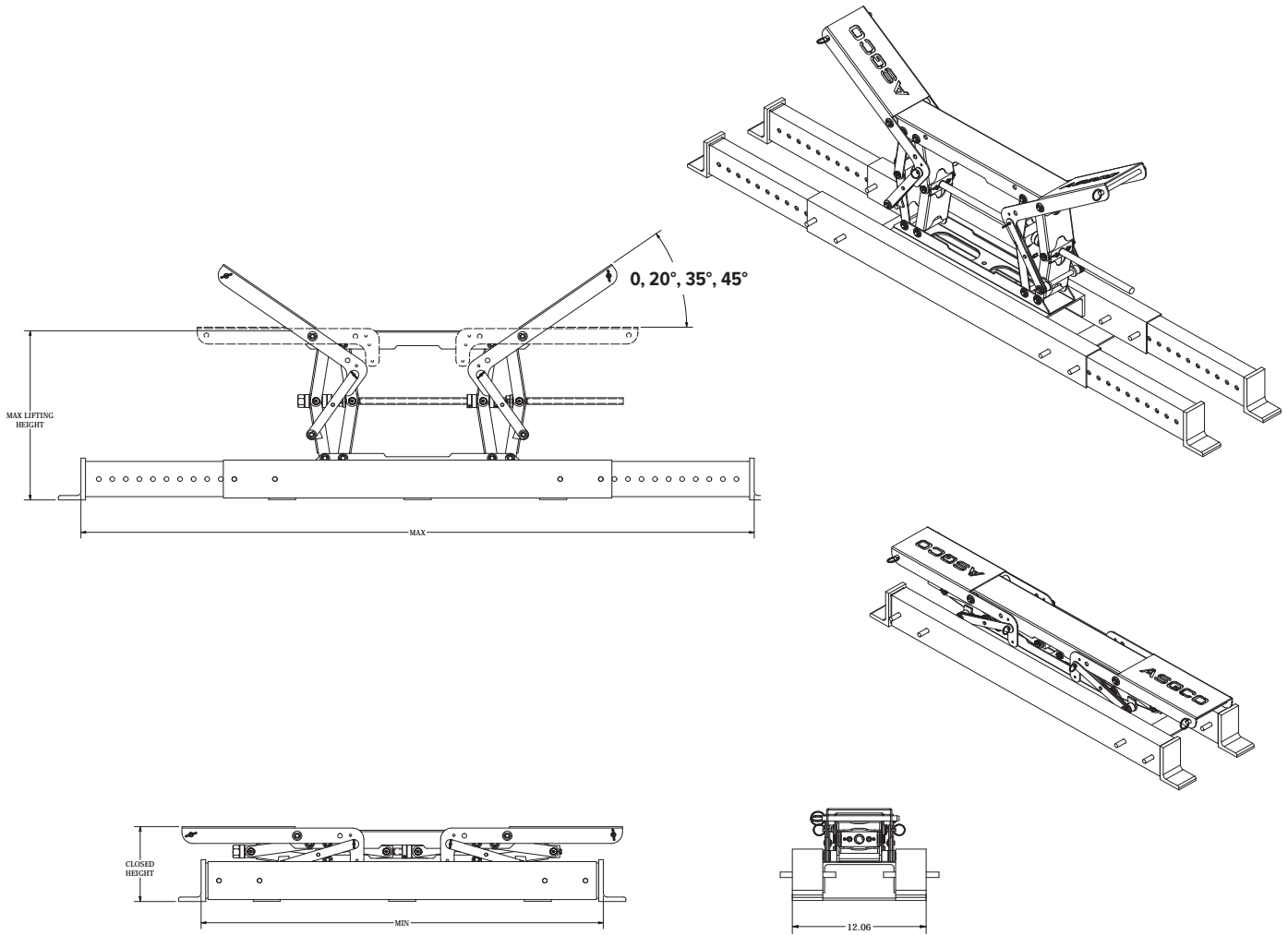

Need Solutions...to improve efficiency, safety and productivity? ask... ASGCO®
www.asgco.com | 800.344.4000
 @2024 ASGCO® "Complete Conveyor Solutions"

