



MINI-SKALPER[®]

with E-Z Torque[®]

INSTALLATION, OPERATION & MAINTENANCE INSTRUCTIONS

For All Mini-Skalper Blade Types

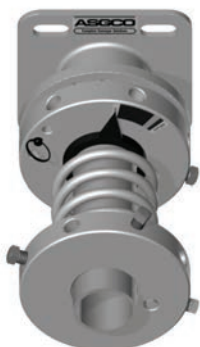
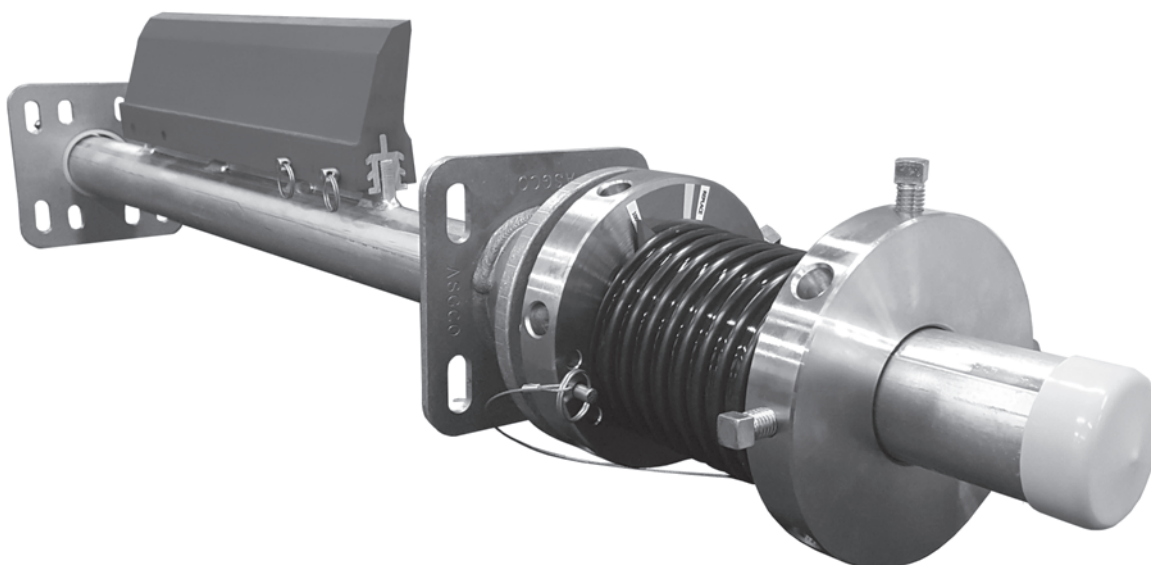

E-Z Torque[®]

U.S. Patent No. 5,992,614
Other Patents Pending

Check us out at
www.asgco.com

Customer Service
800-344-4000



24 Hour Emergency
Service and Parts
610-821-0210

ASGCO Mfg., Inc.
730 Bangor Rd.
Nazareth, PA 18064
610-821-0216
FAX 610-778-8991

Important Safety Notice

Always observe the basic rules of safety when working with any conveyor system. To avoid injury and equipment damage, be sure that all controls to the conveyor are locked out and the power source is disconnected at all times during installation.

Overall View

If mounting structure is not available, additional steel may have to be added. *Note: Excess mounting tube may be trimmed after installation. Also note required lubrication of components.*

Components Diagram

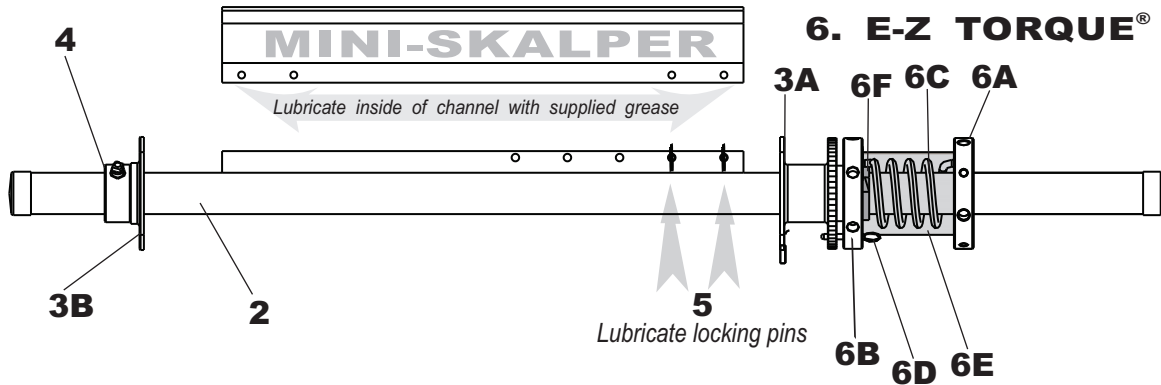

1. E-Z Skalper® Blade
2. Mounting Tube
- 3A. Tensioner Mounting Plate with Bushing
- 3B. Opposite Side Mounting Plate with Bushing
4. Locking Collar with Set Screws
5. Blade Locking Pins (2)
6. E-Z Torque®
- 6A. Outer Tensioner Collar with set screws
- 6B. Inner Tensioner Collar with set screw
- 6C. Spring (Heavy Duty Spring for 48" belt and wider)
- 6D. Tensioner Locking Pin
- 6E. Spring Cover
- 6F. Blade Wear Indicator Ring

1. Determine the Critical "N" Dimension

Determining the "N" dimension, the distance from the belt surface to the mounting tube center, is critical to get the maximum cleaning performance from your system. Make sure mounting tube and tensioner system are clear of obstacles.

| "N" Dimension Table | |
|--|------------------------------|
| Pulley Diameter inches [mm] | "N" Dimension inches [mm] |
| Note the tolerance is $\pm 1/4"$ [6mm] | |
| 6" [150mm] | 4-3/8" [112mm] |
| 8" [205mm] | 4" [102mm] |
| 10" [255mm] | 3-5/8" [92mm] |
| 12" [305mm] | 3-3/8" [86mm] |
| 14" [355mm] | 3-1/8" [80mm] |
| 16" + [600mm] | 3" [76mm] |

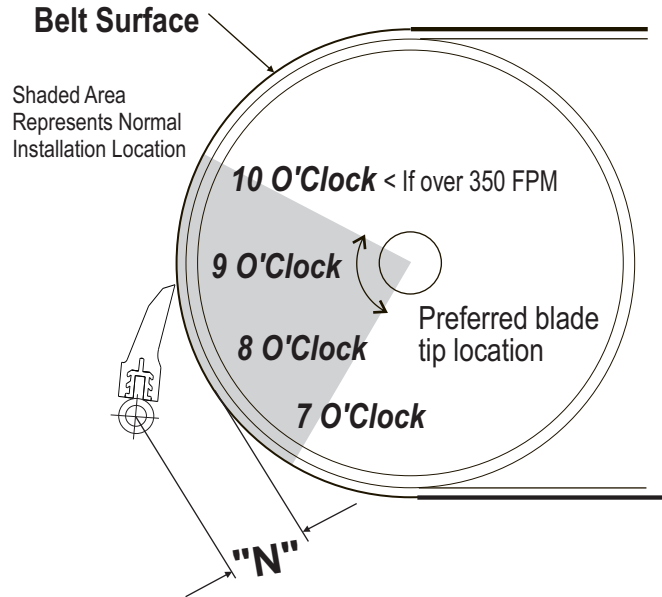
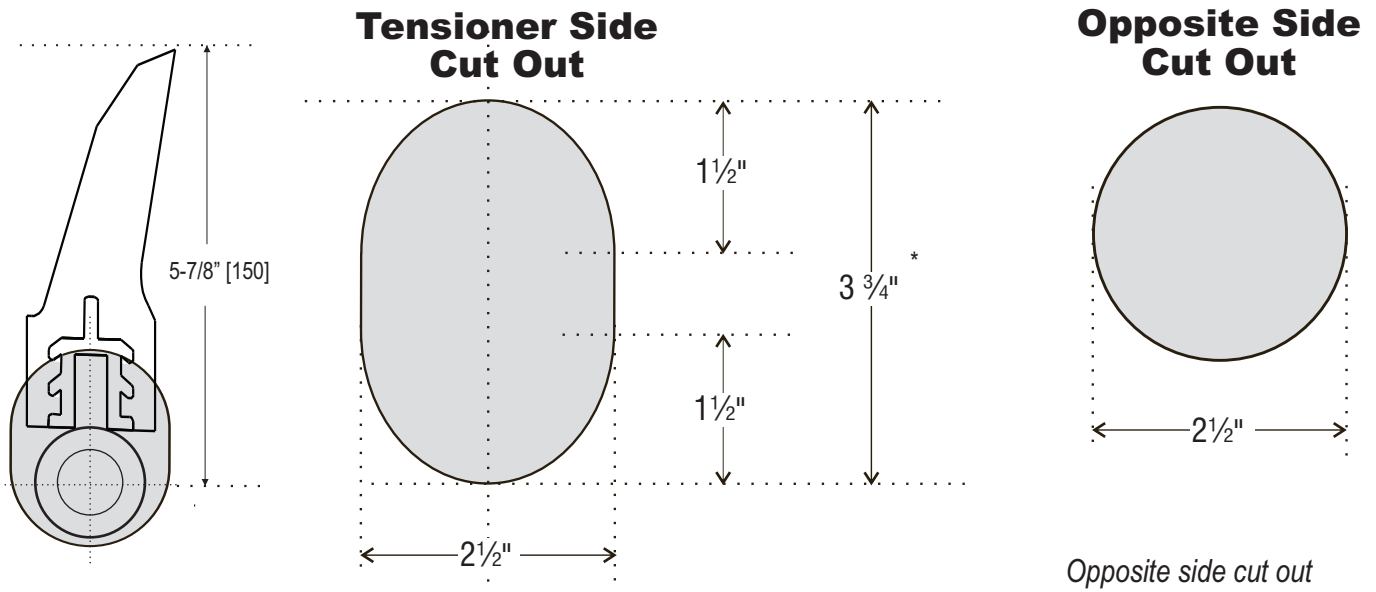

Figure 1: Typical Mounting Position
*Note: $\pm 1/4"$ tolerance

2. Cut Chute Openings

Determining the desired location of the mounting brackets. The required slot sizes/locations are shown for the tensioner side chute cut outs.



*Dimension is 6" for BW 72" and greater

Opposite side cut out is a 2 1/2" hole to install mounting tube

3. Put Mounting Tube through Cut Outs

Place the mounting tube through the chute cut outs so that the long tube section is on the tensioner side. Place the blade onto the blade holder. Visually check the blade position and contact with the belt/pulley.

4. Mount Brackets

Determine the desired location of the mounting brackets. Attach the mounting brackets to the conveyor frame by welding or bolting.

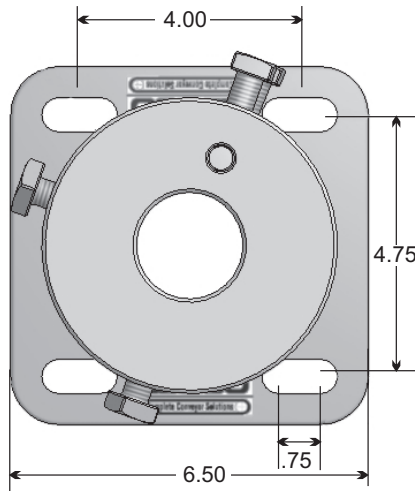

Tensioner Side

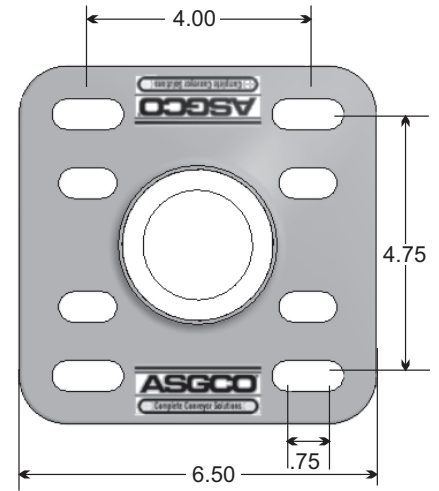

Opposite Side

5. Select Correct Spring

Each Mini-Skalper® System is shipped with two springs of opposite handedness. To determine the proper spring to use:

Face the head pulley as the material would come to you. If the E-Z Torque® tensioner is to your right side, then use the Silver Spring (entire spring is silver-grey). If the tensioner is to your left, then use the Gold Spring (yellow tipped spring).

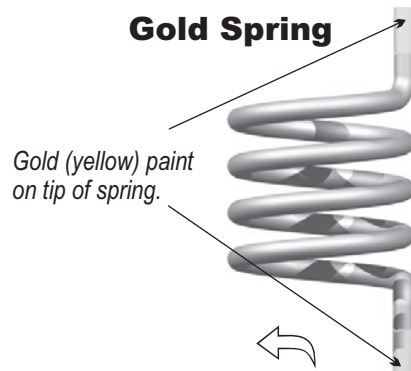

6. Assemble E-Z

Torque® Tensioner:

Assemble the components of the E-Z Torque® tensioner. Tighten all set screw to 70 ft./lbs.

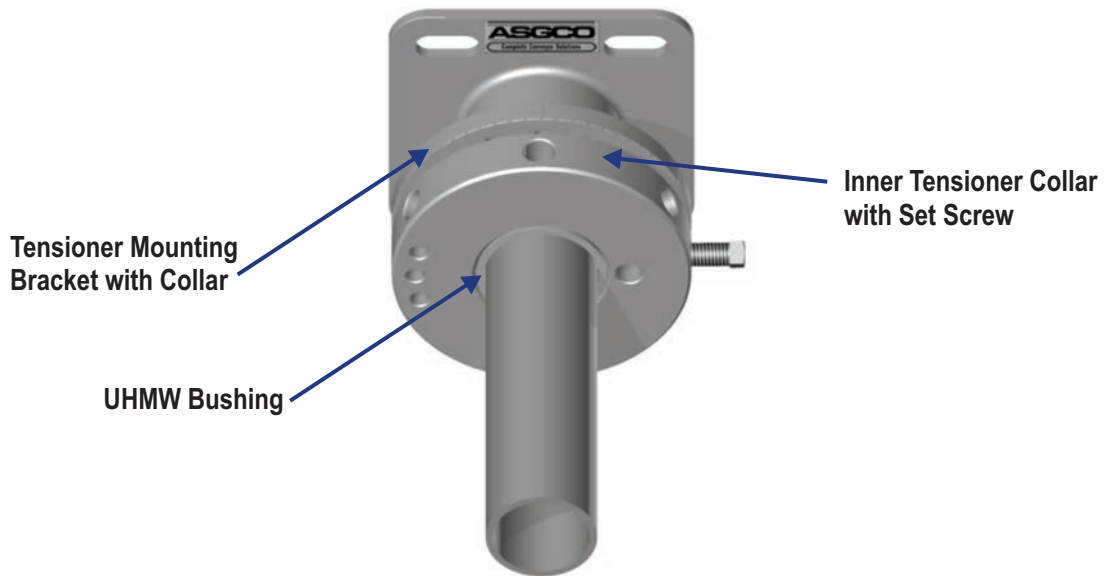

Slide UHMW bushing onto the tensioner mounting bracket. Then slide the inner tensioner collar onto the UHMW bushing.



Slide ring onto the mounting tube, flush with the UHMW bushing. Do not tighten the set screws on the ring in this step.

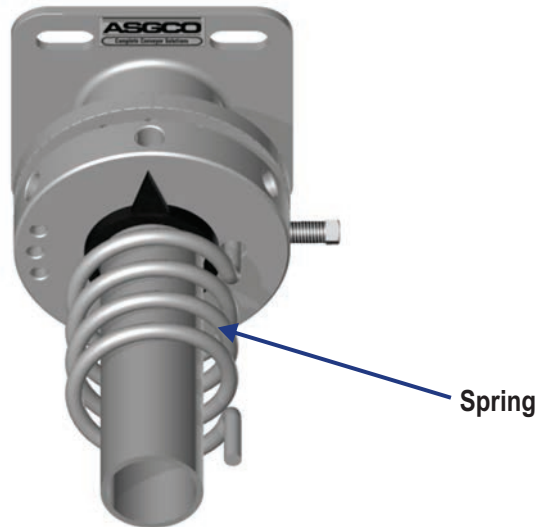

Insert one end of the spring into the Inner Tension Collar. The end of the spring should be seated all the way through the collar. Ring should be able to move freely though out installation. Do not tighten set screw until both collars are in place.

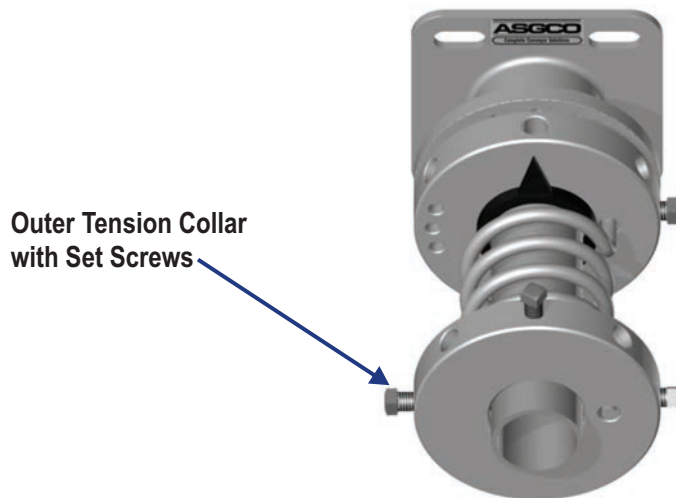

Slide the Outer Tension Collar onto the pipe and spring. With both collars in place, tighten the set screws on both ends of the spring and the set screws on the mounting tube. Assemble the components of the E-Z Torque® tensioner. Tighten all set screws to 70 ft./lbs.

7. Tension Assembly

Set torque to approximately one (1) lb. of force per inch of blade width - approximately 30 lbs of force for a 30" blade. For the standard duty spring, 1 degree of collar rotation will apply about 1 ft-lb of torque (1 ft-lb torque will give approximately 1 lb force at the blade tip). For the heavy duty spring, assume approximately 2 ft-lbs of torque per degree of rotation. Decrease or increase the torque as necessary. Using the minimum amount of blade force required to clean the belt will extend blade life. The tensioning rod will enable approximate blade tensioning. Use a torque wrench with adapter to more accurately tension the blade.

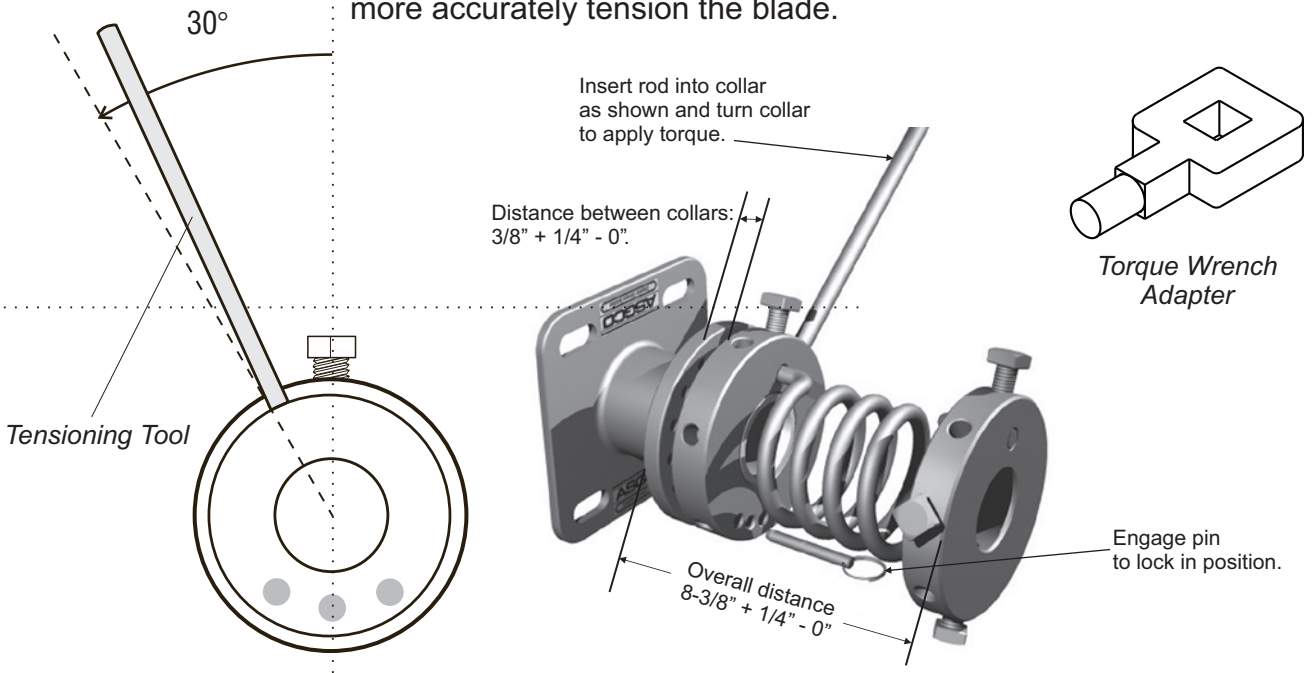

8. Set Wear Indicator:

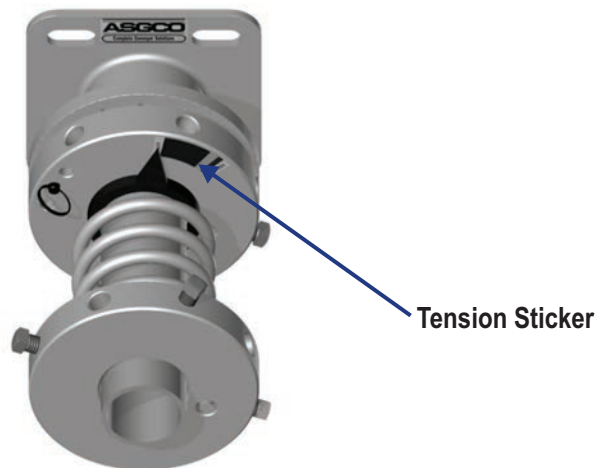

With the system tensioned, place the blade wear sticker on the Inner Tension Collar. It is recommended to align the sticker 90 degrees from the pin and spring hole on the collar, to ensure the indicator can travel the full distance required to measure blade life. Position the ring at the 100% line on the blade wear sticker and tighten the set screws on the ring.

Should the more tension be added throughout the life of the blade, the blade wear ring will need to be loosened and then repositioned to indicate the correct amount of blade life.

9. Maintenance:

- 1.)** Frequent inspections is the key to proper belt cleaning and easy scraper servicing. Weekly inspections are recommended, but actual service frequency may vary widely depending on various plant operating conditions.

- 2.)** Inspect the belt surfaces and edges for cracks, splits, tears, holes or any other worn or damaged condition occurring on the surfaces or edges of the belt itself. If necessary make repairs to the belt. Wash the entire cleaner regularly to prevent excessive build-up. Check the tightness of all fasteners.

- 3.)** Inspect for proper operation. Adjust tension as required.

- 4.)** Replace the Mini-Skalper® scraper blade as required. Use only ASGCO® “Complete Conveyor Solutions” approved replacement scraper blades.

Information

| Key | Description | Part Number |
|-----|---------------------------------|---|
| 1 | Mini-Skalper® Blade Replacement | ASG-SK4M[X]-[BW]-A-1 [X]=Blade Type, [BW]=Blade Width |
| 2 | Mini-Skalper® Mounting Tube | ASG-SKMT-[BW]AM-1 |
| 3A | Mounting Bracket Tension Side | ASG-EZT-TS-ASM-2 (Includes Bushing) |
| 3B | Mounting Bracket Opposite Side | ASG-F1-MB-OS-2 |
| | Bushing (Off-Side) | ASG-F1-UHMW-BUSHING-1 |
| 4 | Locking Collar with Set Screws | ASG-F1-LC-1 |
| 5 | E-Z Torque® | M-ASG-EZT-2 |
| | Bushing (Tension Side) | ASG-UHMW-BUSHING-1 |
| 5A | Outside Collar | ASG-EZT-OCHS-SS-2 |
| 5B | Inside Collar | ASG-EZT-ILC-SS-2 |
| 5C | Spring | ASG-ROT-[LS or RS]-1242-SS-1 |
| 5D | Locking Pin (Tensioner) | M-ASG-ROT-LPC |
| | Rotary Tensioning Tool | ASG-ROT-TT-SS |
| 5E | Spring Cover | ASG-EZT-SPRING-COVER-1 |
| 5F | Blade Wear Indicator Ring | ASG-EZT-IND-RING |

Call your ASGCO Distributor for any questions or replacement parts

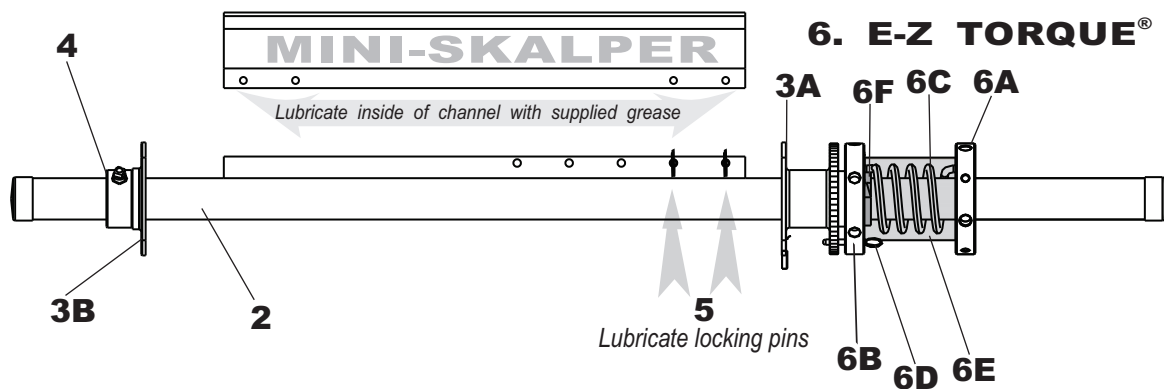

TROUBLE SHOOTING

| PROBLEM | SOLUTION |
|---|---|
| <i>Excess vibration of the scraper.</i> | <p>Make certain all bolts are tight and the pin is securely engaged on the tensioner.</p> <p>Ensure the cleaners n-dimension is proper (See Table and Figure 1).</p> |
| <i>Excess carryback.</i> | <p>Check for excess build-up on the scraper.</p> <p>Check for proper Scraper tension. Put additional tension on cleaner.</p> <p>Check for non-uniform scraper wear.</p> <p>Check N-dimension.</p> <p>Clean the back-side of the belt cleaner.</p> |
| <i>Check for wear on the cleaning tips.</i> | <p>Check thickness of carry-back. If the cleaner must remove more than about 1/8" of material then an additional cleaner may be needed.</p> |
| <i>Frozen material on scraper.</i> | <p>Place heaters near scraper to melt frozen material. (Use caution not to burn belt or cleaner)</p> |
| <i>Blade wearing in center</i> | <p>Install a new blade that concentrates cleaning in the center of the flow of the material. (Belt Width - 6" or Belt Width - 12")</p> |
| <i>Blade wearing more on one side</i> | <p>Check N-dimension.</p> |
| <i>Breaking Tensioner Pin</i> | <p>Consider the type of splice in the belt. If there is a mechanical fasteners splice, make sure the belt top cover is skived to allow the cleaner to pass over the splice.</p> |