

**WAGENER**

*Schwelm*

*vulcanizing presses since 1897*

## SPECIAL PRESSES

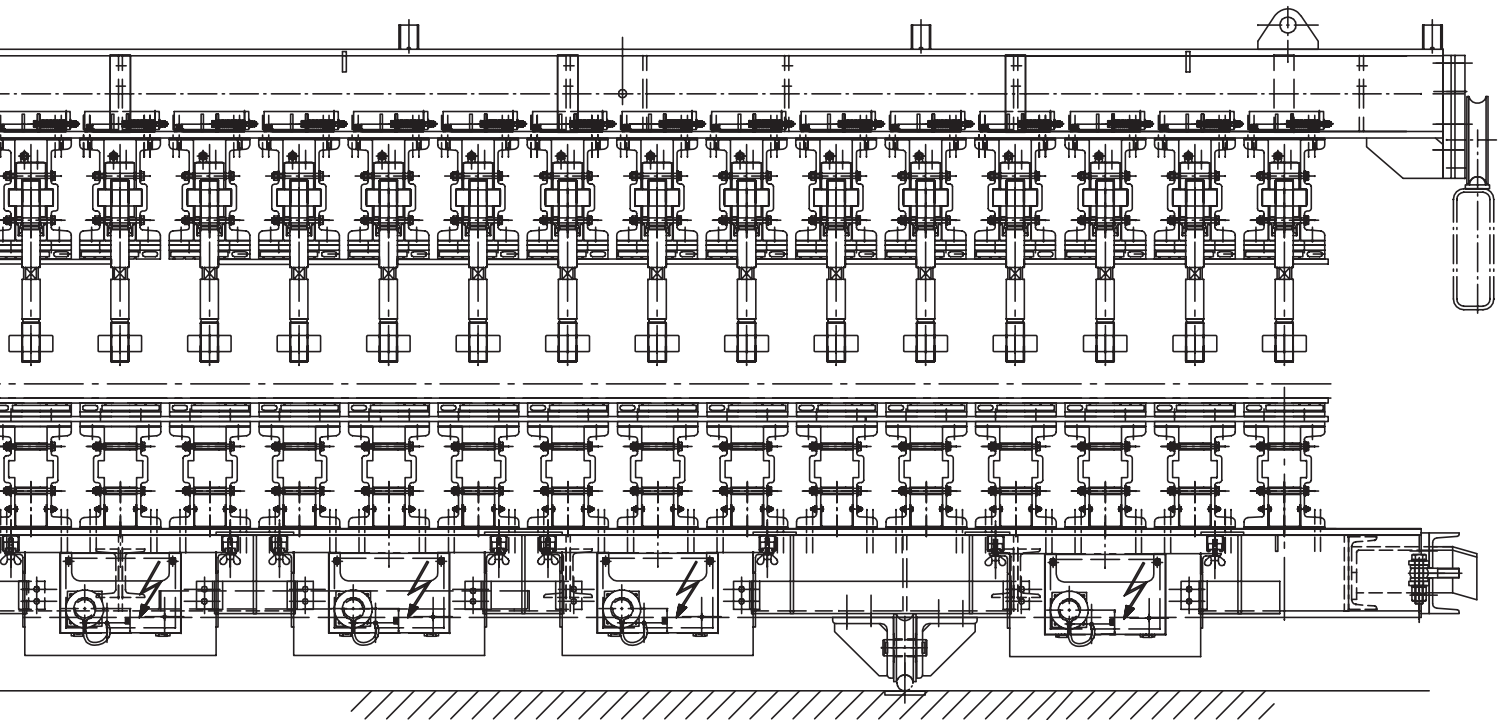

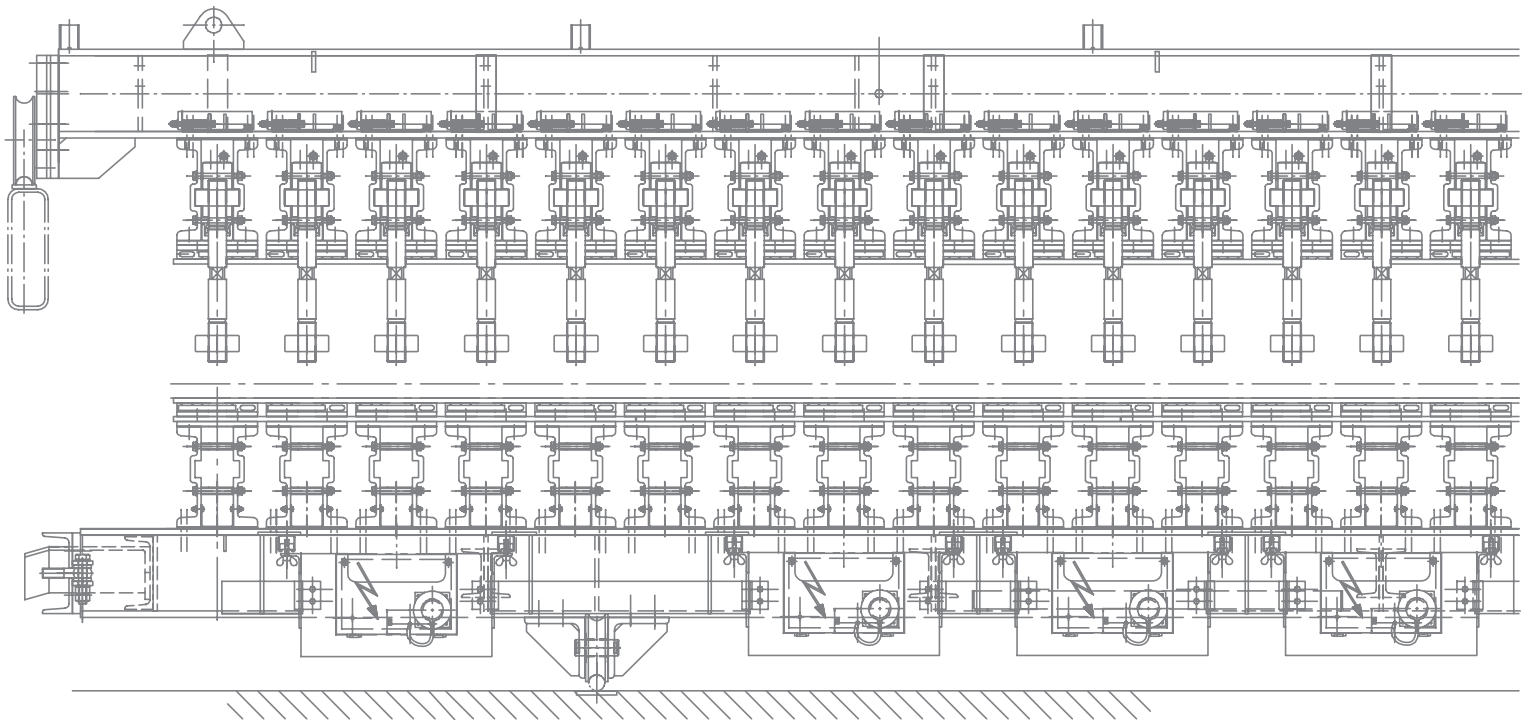

## Content

4	8-storey press
5 - 6	semi-stationary EMU-Liquid
7	Compact press type J16
8	jointing press
9	Sidewall pressing device
10	stationary vulcanizing press
11	stationary vulcanizing press for elevator belts
12 - 13	Tunnel vulcanizing plant
14	Belt cutting machine WacoCut
15	Packaging plant
16	Mini compact press
17	Cable vulcanizing apparatus
18	Compact press type J28F / J28E
19	semi-stationary KLIV-Cycon-Modul
20 - 21	Compact press type J22 / J22-001
22	stationary vulcanizing press SVP / 2800
23	semi-stationary KLIV-Cycon-Modul
24	semi-stationary EMU-Liquid
25	edge press
26 - 27	jaw presses
28 - 29	container
30	Longitudinal crack press Floecksmühle
	Stationary film sealing device

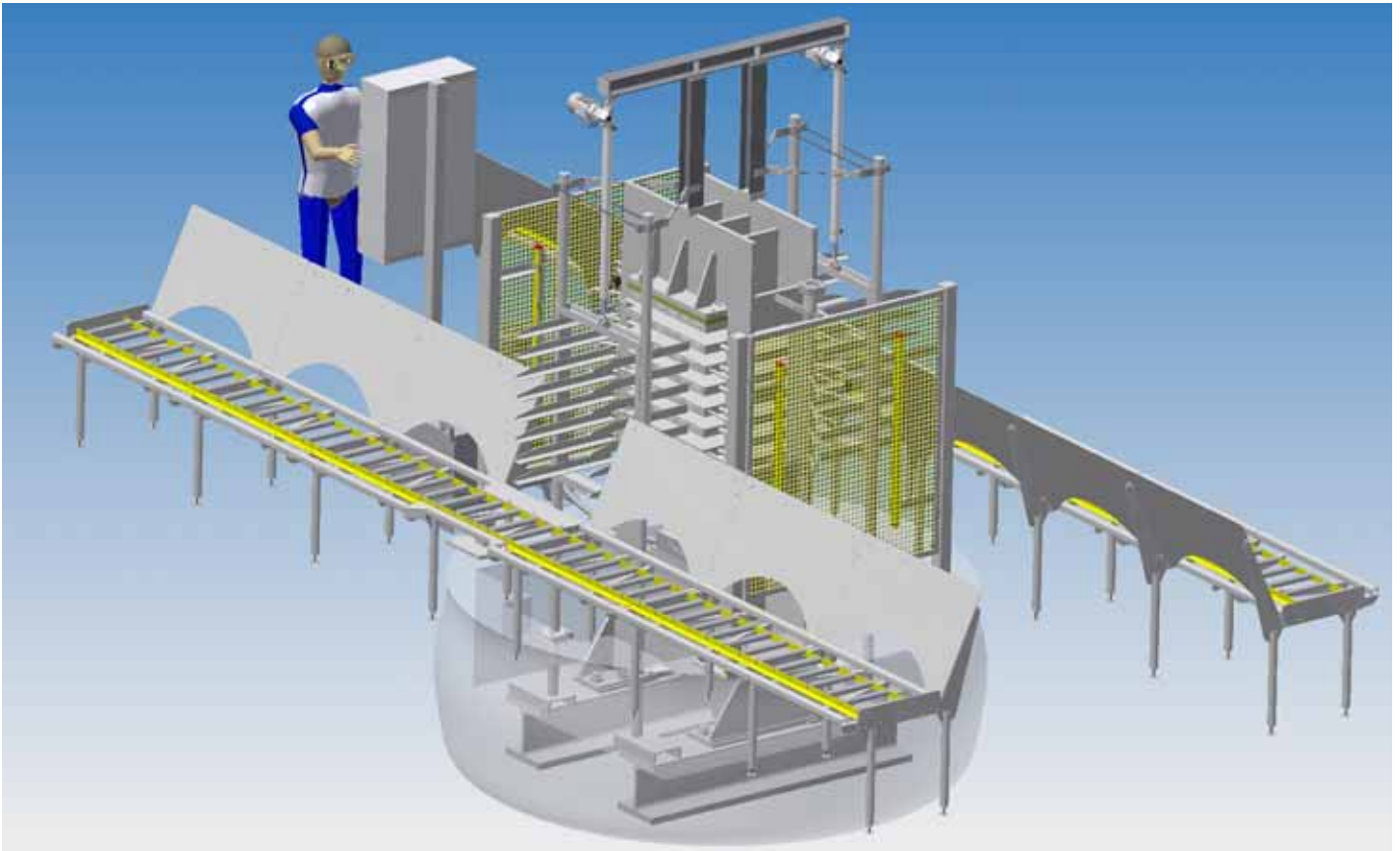

### 8-storey press

Heating surface (W x L): 700 x 700 mm<sup>2</sup> (8x)

Surface pressure: 225 N/cm<sup>2</sup>

Pressure medium: oil hydraulic cylinder

Max. Heating temperature: 150 °C

Heating medium: water vapour

Cooling: without

Voltage: 400V/3Ph

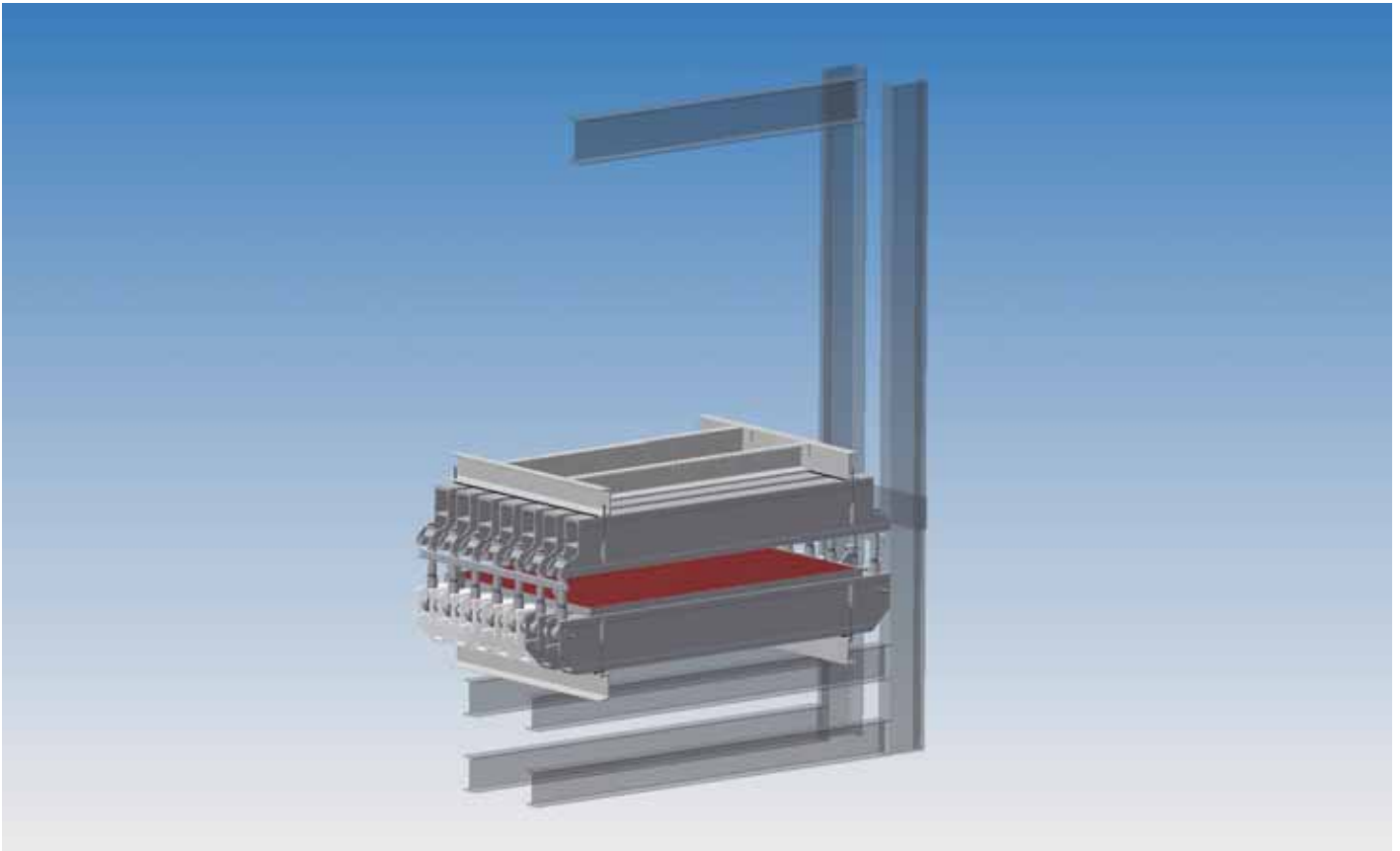

### **semi-stationary EMU-Liquid**

Heating surface (W x L): 1550 x 1000 mm<sup>2</sup> (for belt width 1400 mm)

Surface pressure: 100 / 120 / 140 N/cm<sup>2</sup> (pressure levels selectable)

Pressure medium: water hydraulic pressure pads

Max. Heating temperature: 175 °C

Heating medium: Heating mat

Heating capacity: 20 kW

Cooling: Water

Voltage: 400V/3Ph

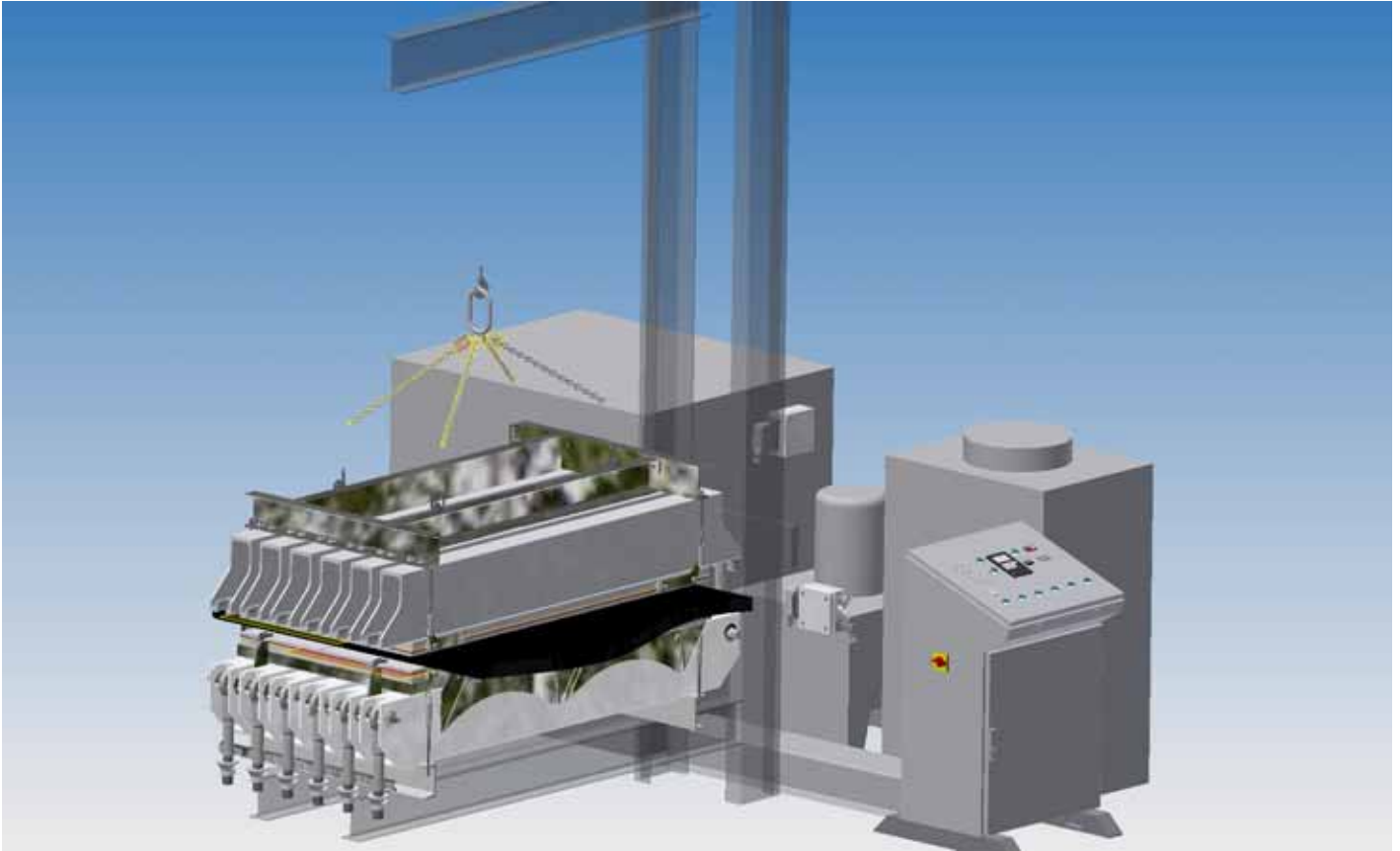

### semi-stationary EMU-Liquid

Heating surface (W x L): 1550 x 800 mm<sup>2</sup> (for belt width 1400 mm)

Surface pressure: 140 N/cm<sup>2</sup>

Pressure medium: water hydraulic pressure pads

Max. Heating temperature: 175 °C

Heating medium: Heating mat

Heating capacity: 16,2 kW

Cooling: Water

Voltage: 400V/3Ph

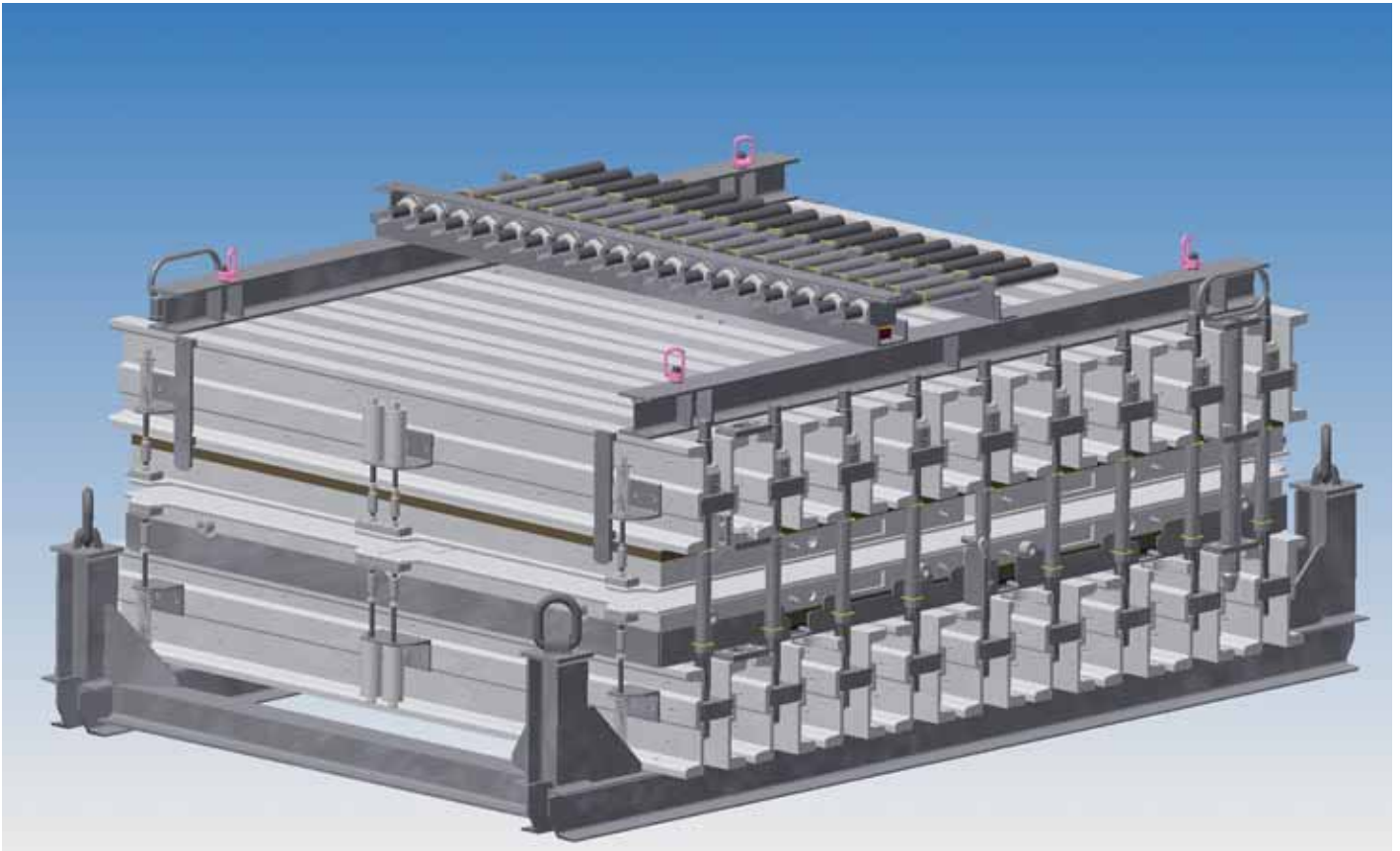

### Compact press Typ J16

Heating surface (W x L): 1700 x 2050 mm<sup>2</sup> (for belt width 1600 mm)

Surface pressure: 140 N/cm<sup>2</sup>

Pressure medium: water hydraulic pressure pads

Max. Heating temperature: 175 °C

Heating medium: Tubular heating element

Heating capacity: 59,4 kW

Cooling: Water

Voltage: 500V/3Ph

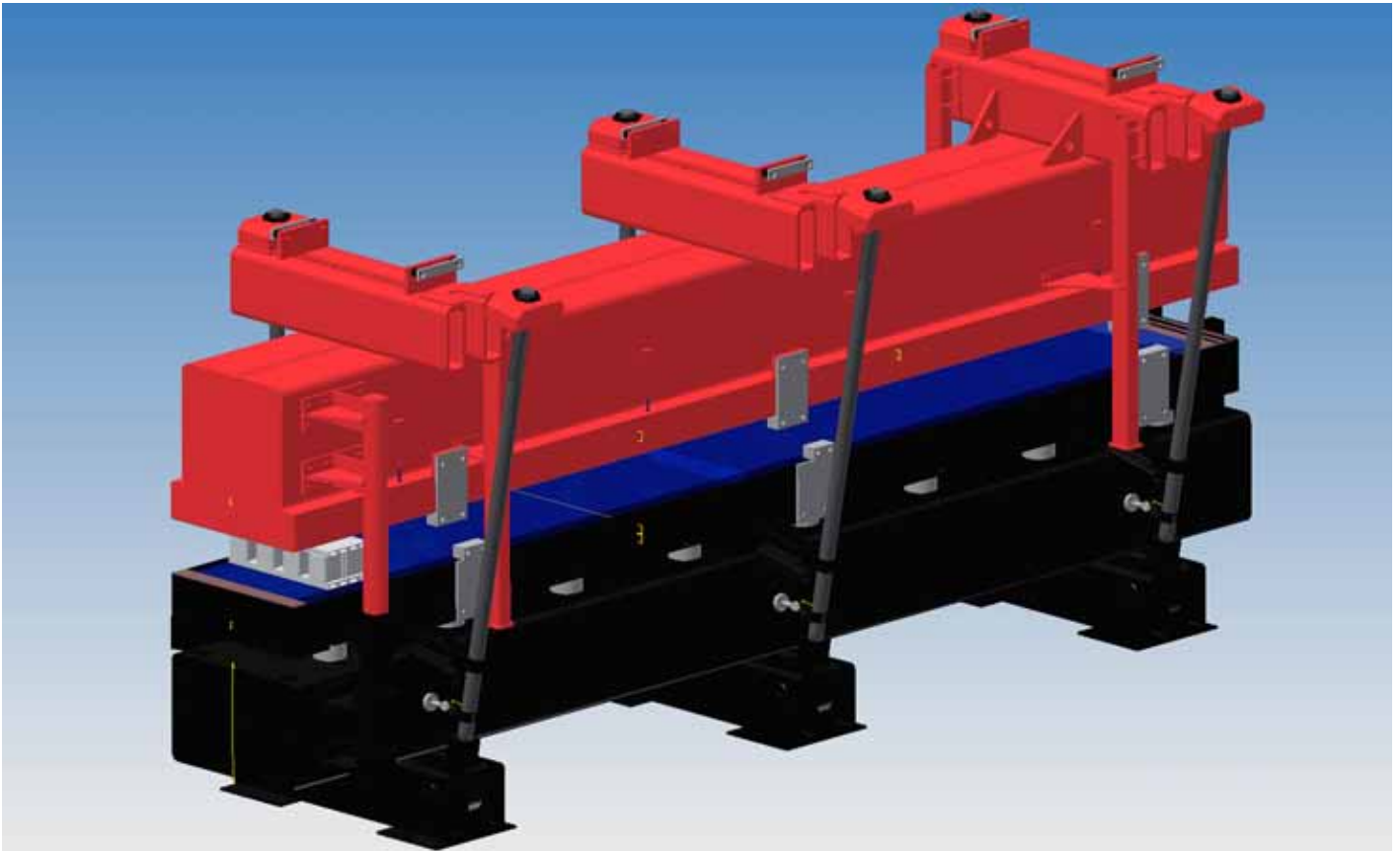

### jointing press

Heating surface (W x L): 500 x 4490 mm<sup>2</sup>

Surface pressure: 140 N/cm<sup>2</sup>

Pressure medium: oil hydraulic cylinder

Max. Heating temperature: 175 °C

Heating medium: Tubular heating element

Heating capacity: 32,5 kW

Cooling: Water

Voltage: 400V/3Ph





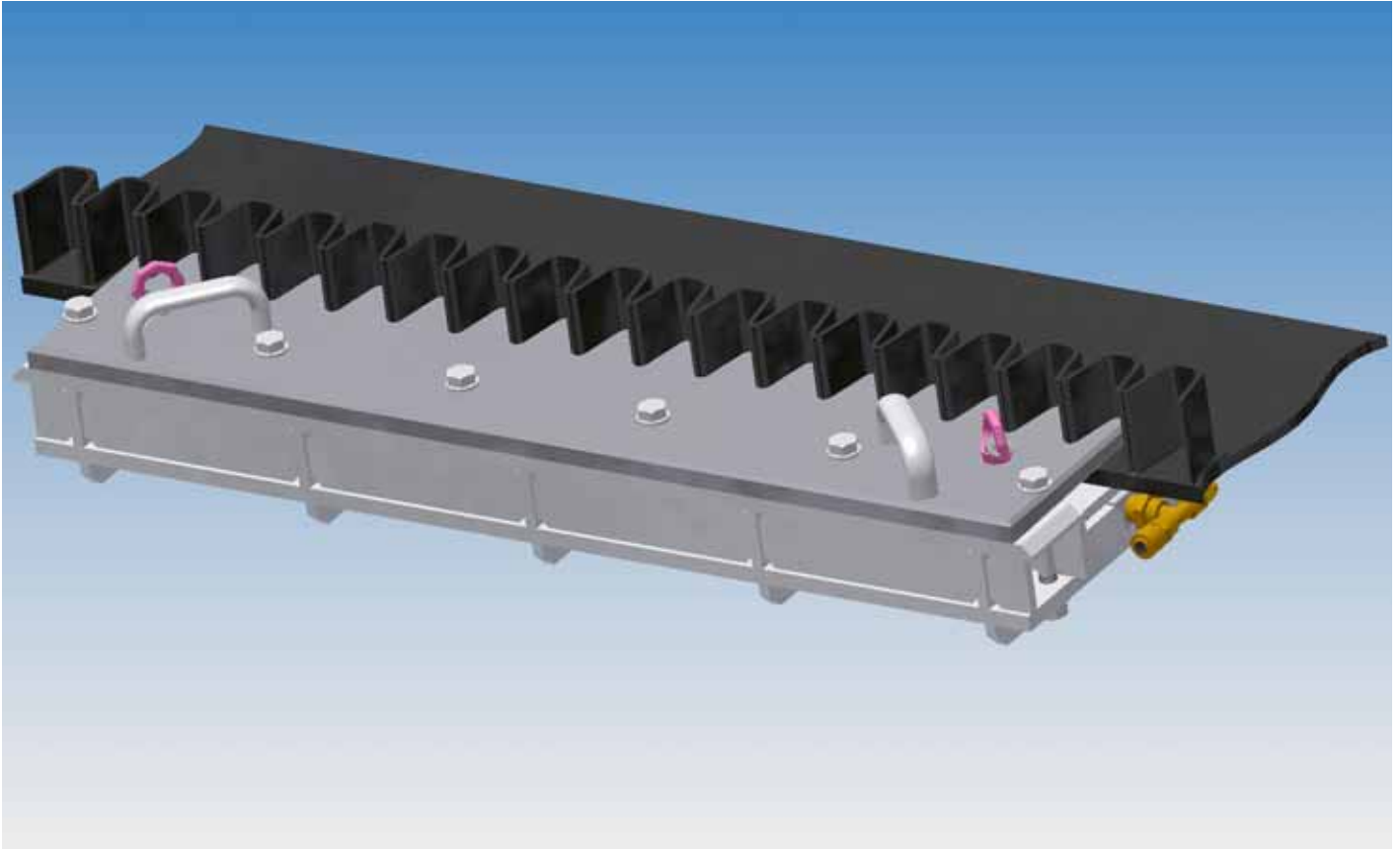

### Sidewall pressing device

Pressure length: 1000 mm

Surface pressure: 70 N/cm<sup>2</sup>

Pressure medium: Pneumatic pressure pads

Heating medium: without

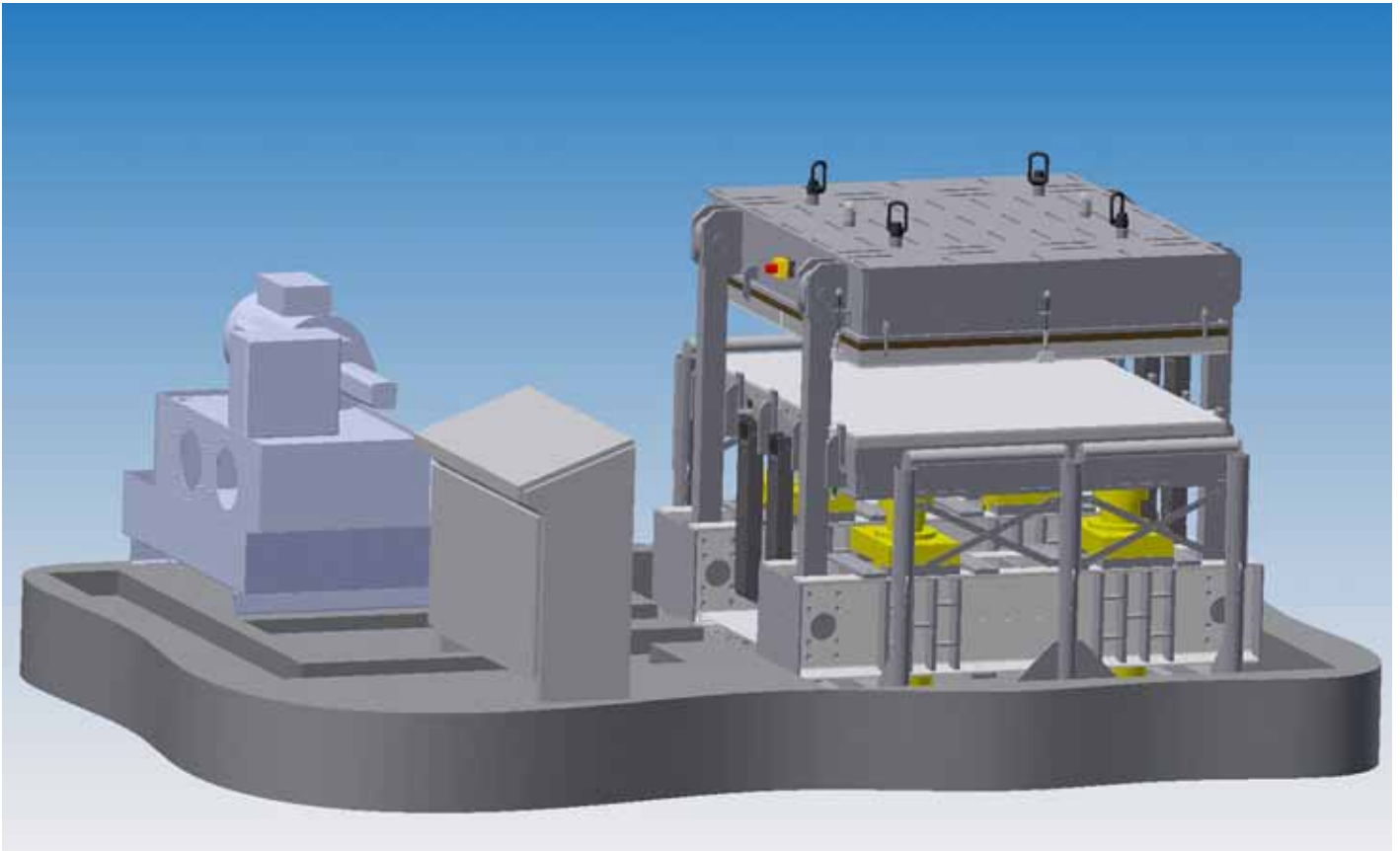

### stationary vulcanizing press

Heating surface (W x L): 1550 x 1800 mm<sup>2</sup> (for belt width 1400 mm)

Surface pressure: 110 N/cm<sup>2</sup>

Pressure medium: oil hydraulic cylinder

Max. Heating temperature: 175 °C

Heating medium: Tubular heating element

Heating capacity: 48,4 kW

Cooling: Water

Voltage: 400V/3Ph

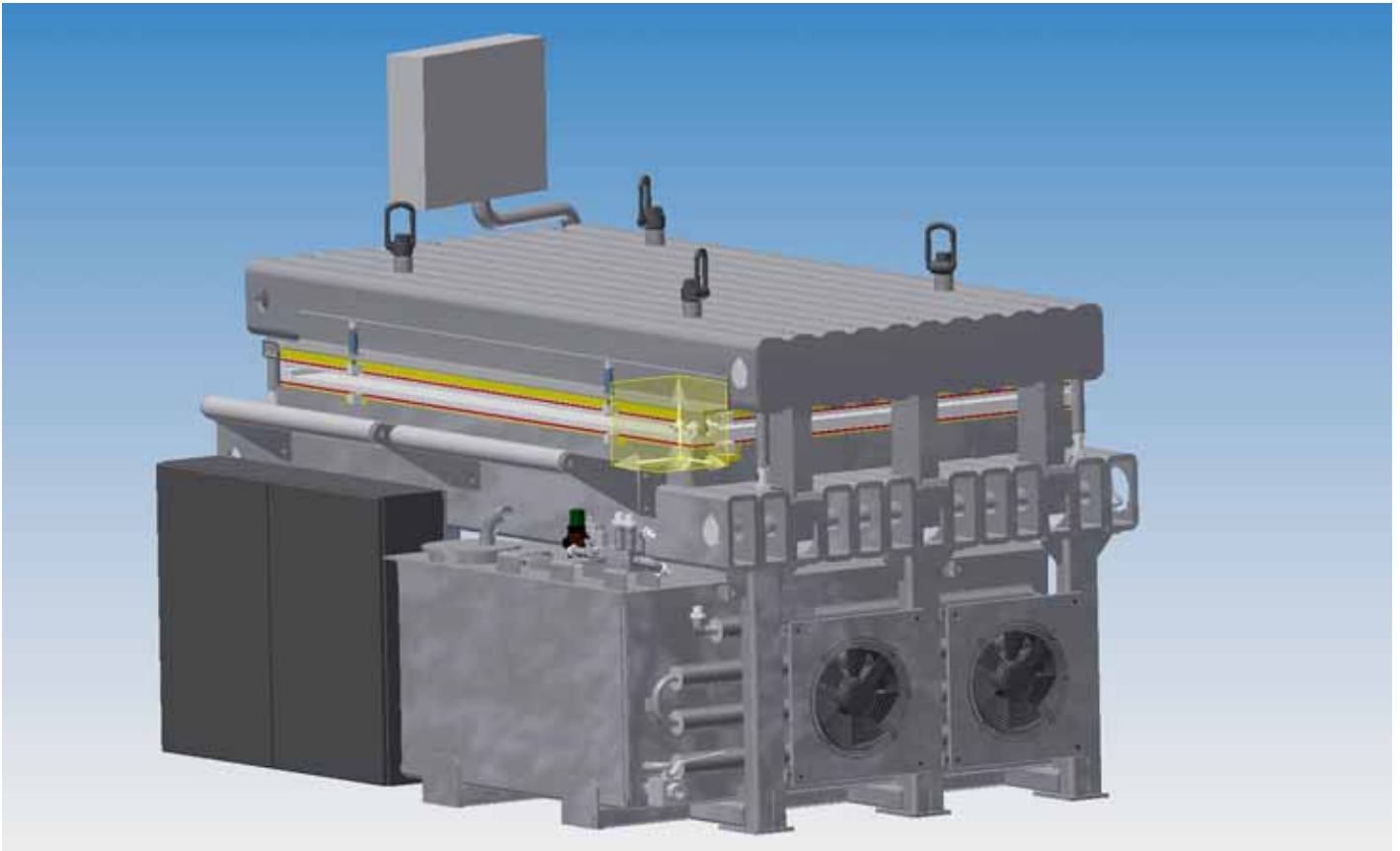

### **stationary vulcanizing press for elevator belts**

Heating surface (W x L): 1850 x 1200 mm<sup>2</sup> (for belt width 1700 mm)

Surface pressure: 125 N/cm<sup>2</sup>

Pressure medium: water hydraulic pressure pads

Max. Heating temperature: 175 °C

Heating medium: Tubular heating element

Heating capacity: 28,8 kW

Cooling: Water

Voltage: 400V/3Ph

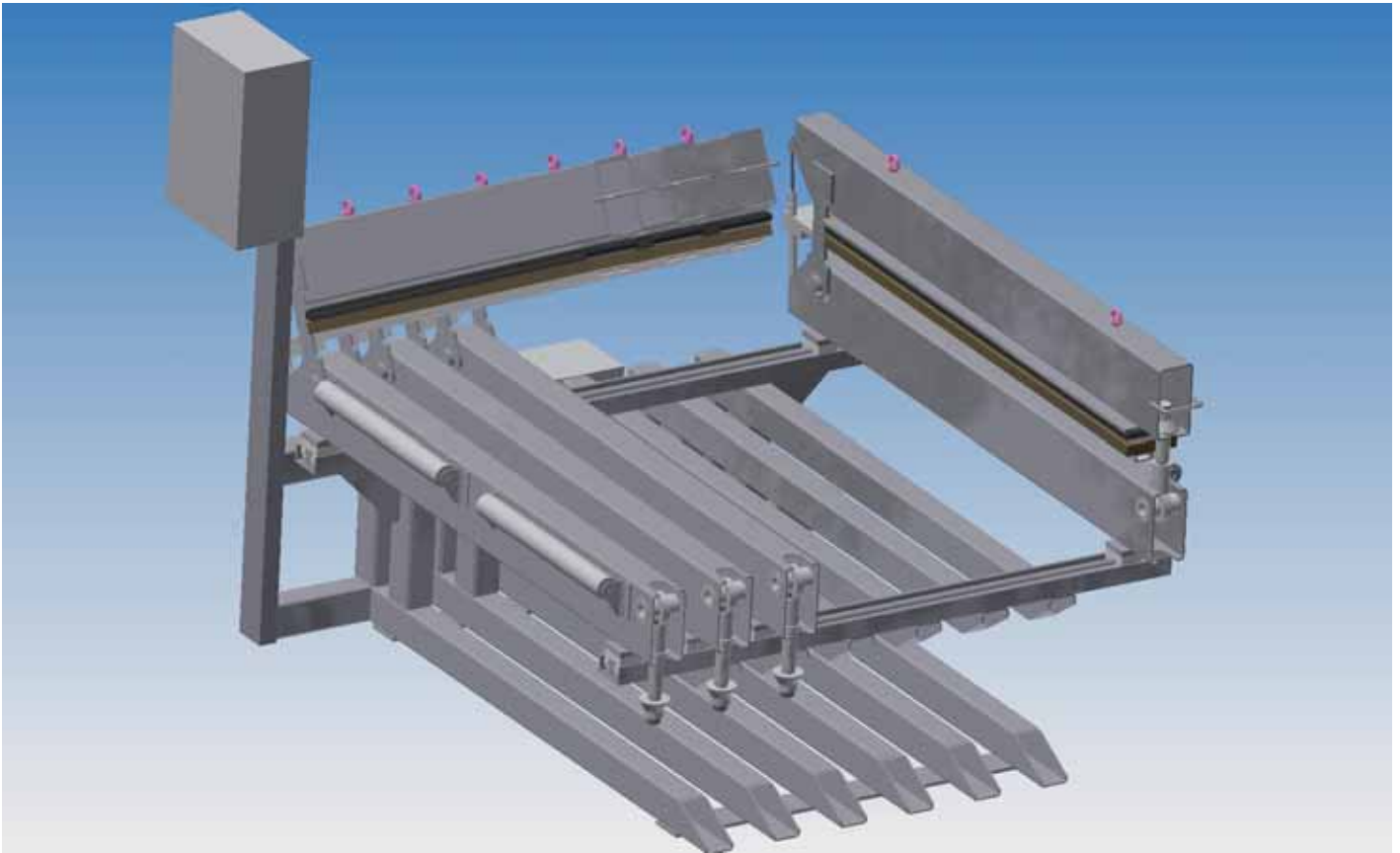

### Tunnel vulcanizing plant

Heating surface (W x L): 1500 x 100 mm<sup>2</sup> (4x)

Surface pressure: 125 N/cm<sup>2</sup>

Pressure medium: Pneumatic pressure pads

Max. Heating temperature: 175 °C

Heating medium: Tubular heating element

Heating capacity: 8 kW

Cooling: without

Voltage: 400V/3Ph

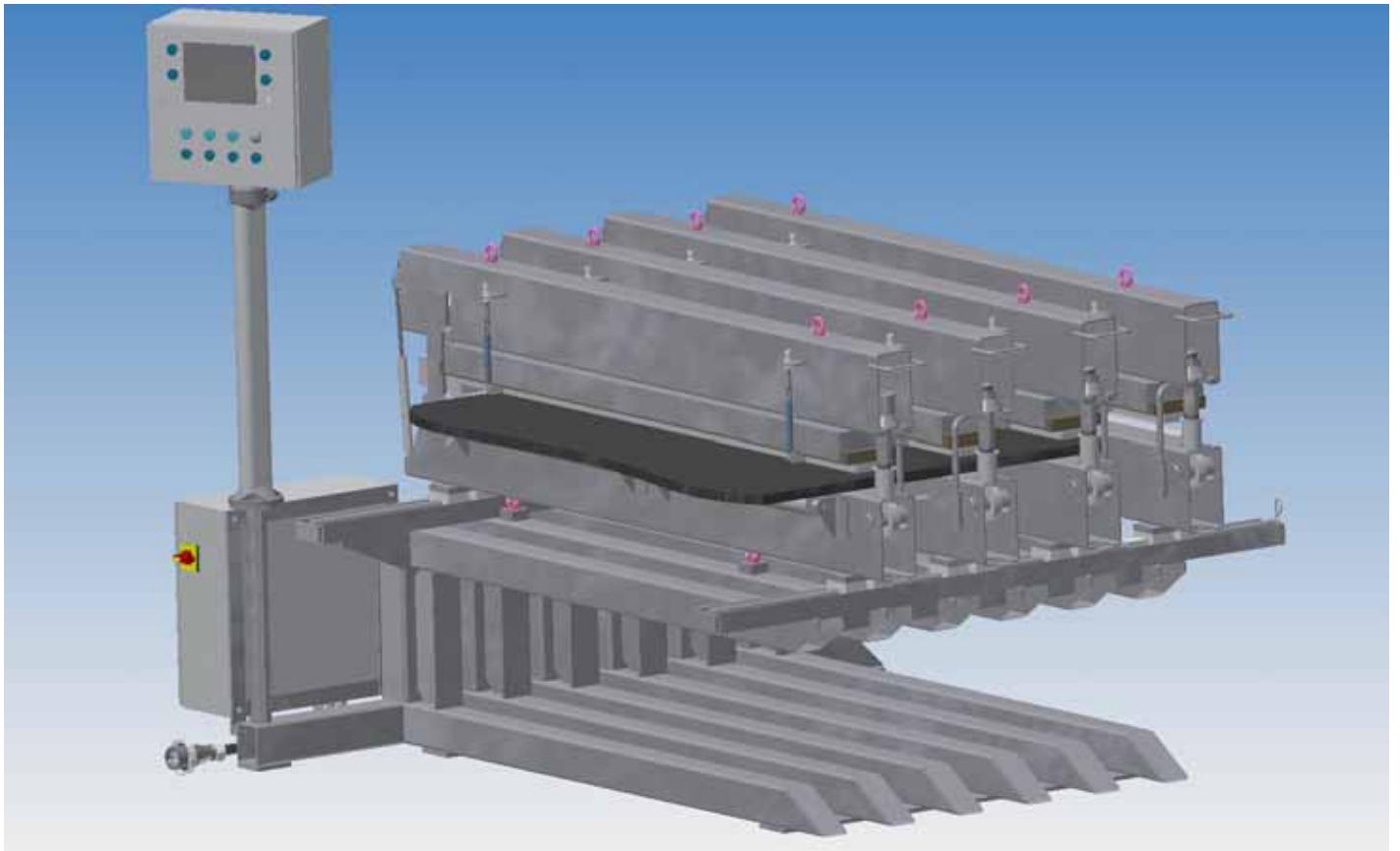

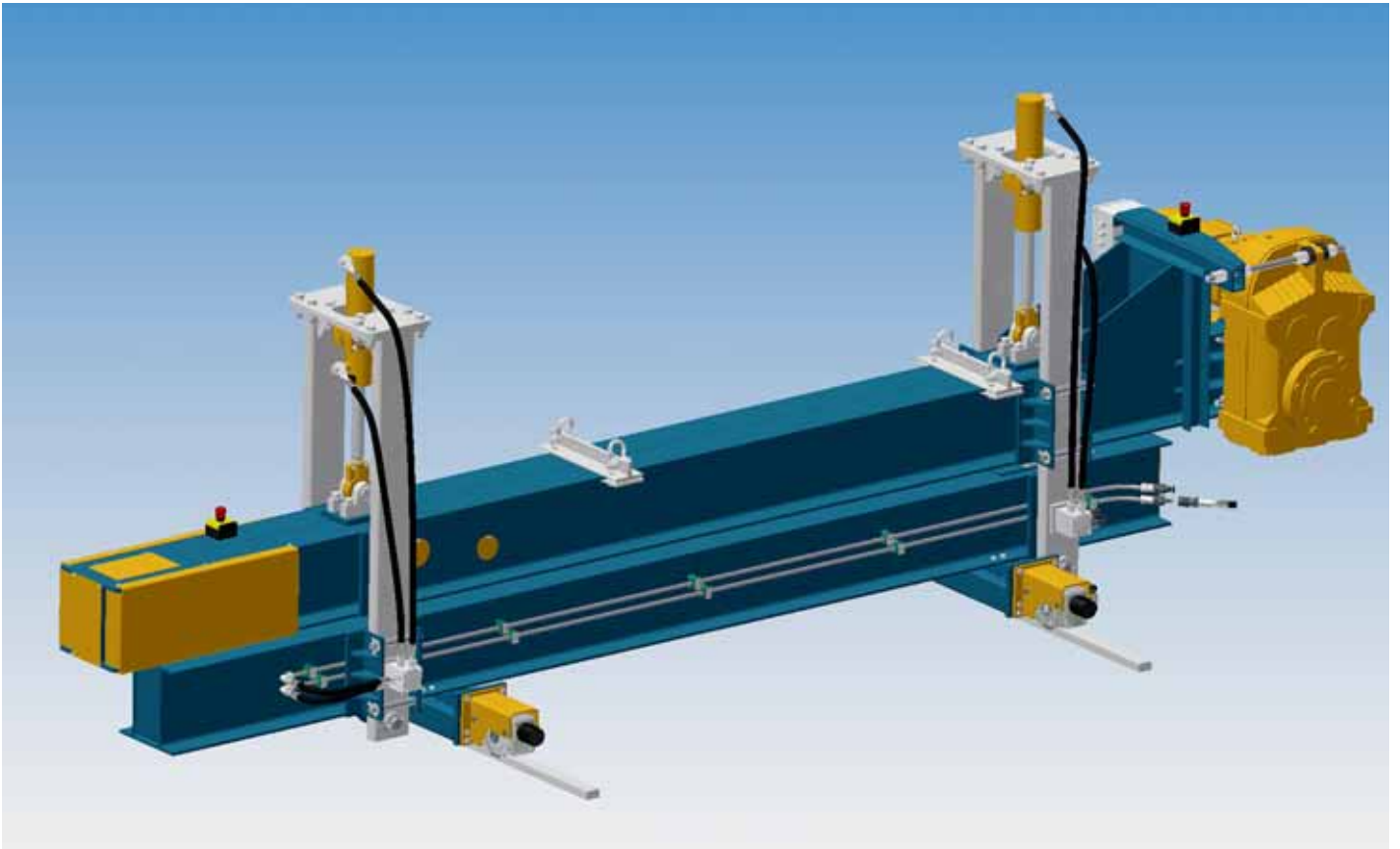

### Belt cutting machine WacoCut

Max. belt to be cut: 50 mm  
Cutting length Max.: 2600 mm  
Voltage: 400V/3Ph

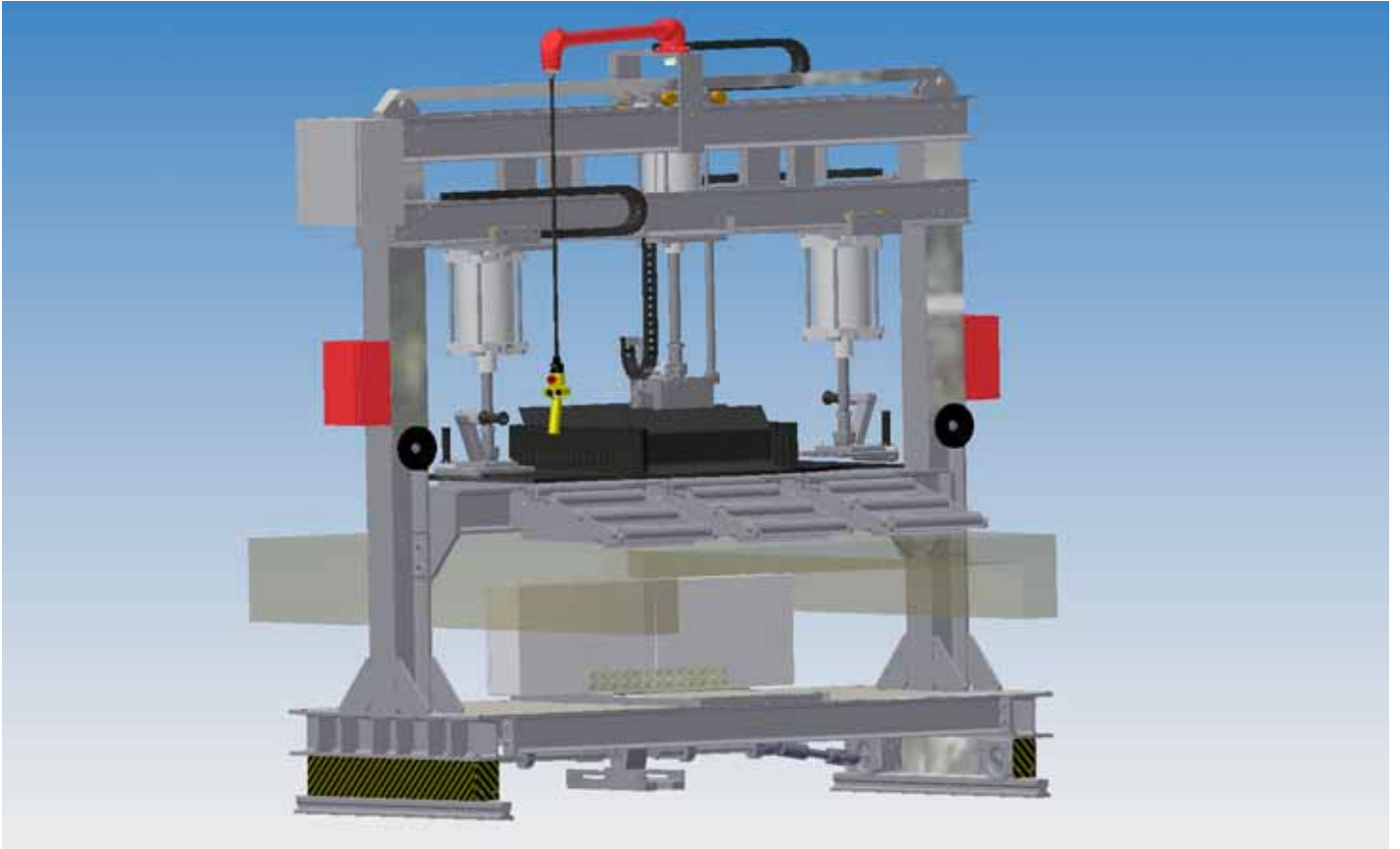

### Packaging plant

Belt width max.: 1600 mm

Surface pressure: 60 N/cm<sup>2</sup>

Pressure medium: pneumatic cylinder (2 x corrugated edges, 1 x cleats)

Travel length of the system: 5000 mm

Voltage: 400V/3Ph



### Mini compact press

Heating surface (W x L): 150 x 100 mm<sup>2</sup>

Surface pressure: approx. 65 N/cm<sup>2</sup> (very strongly dependent on the strength of the user)

Pressure medium: Pressure spindle

Max. Heating temperature: 195 °C

Heating medium: Tubular heating element

Heating capacity: 0.63 kW

Cooling: without

Voltage: 230V/1Ph





### Cable vulcanizing apparatus

Heating diameter x length: 55 mm or 66 mm x 1200 mm

Max. Heating temperature: 175 °C

Heating medium: Tubular heating element

Heating capacity: 7,5 kW

Cooling: without

Voltage: 400V/3Ph



### Compact press Type J28F / J28E

Heating surface (W x L): 3000 x 2905 mm<sup>2</sup> (for belt width 2800 mm) / 3000 x 2960 mm

Surface pressure: 150 N/cm<sup>2</sup>

Pressure medium: water hydraulic pressure pads

Max. Heating temperature: 175 °C / 150 °C

Heating medium: Tubular heating element KLIV

Heating capacity: 135 kW / 266 kW

Cooling: Water

Voltage: 230V/3Ph



### semi-stationary KLIV-Cycon-Modul

Heating surface (W x L): 1500 x 7100 mm<sup>2</sup> (for belt width 1400 mm)

Surface pressure: 150 N/cm<sup>2</sup>

Pressure medium: oil hydraulic cylinder

Max. Heating temperature: 155 °C

Heating medium: KLIV

Heating capacity: 448 kW

Cooling: Water

Voltage: 500V/3Ph



### Compact press Type J22 / J22-001

Heating surface (W x L): 2400 x 2300 mm<sup>2</sup> (for belt width 2200 mm) / 2400 x 9200 mm<sup>2</sup>

Surface pressure: 140 N/cm<sup>2</sup>

Pressure medium: water hydraulic pressure pads

Max. Heating temperature: 175 °C

Heating medium: Heating mat

Heating capacity: 72 kW / 288 kW

Cooling: Water

Voltage: 400V/3Ph





### stationary vulcanizing press SVP / 2800

Heating surface (W x L): 3000 x 1500 mm<sup>2</sup> (for belt width 2800 mm)

surface pressure: 100, 120 or 140 N/cm<sup>2</sup>

Pressure medium: water hydraulic pressure pads

Max. Heating temperature: 175 °C

Heating medium: Tubular heating element

Heating capacity: 80 kW

Cooling: Water

Voltage: 400V/3Ph





### semi-stationary EMU-Liquid

Heating surface (W x L): 2200 x 1200 mm<sup>2</sup> (for belt width 2000 mm)

Surface pressure: 140 N/cm<sup>2</sup>

Pressure medium: water hydraulic pressure pads

Max. Heating temperature: 175 °C

Heating medium: Heating mat

Heating capacity: 41 kW

Cooling: Water

Voltage: 400V/3Ph





### edge press

Heating length: 1200 / 1600 / 2000 mm  
Surface pressure: 70 N/cm<sup>2</sup>  
Pressure medium: Pneumatic pressure pads  
Max. Heating temperature: 200 °C  
Heating medium: Tubular heating element  
Heating capacity: 10.5 / 14 / 17 kW  
Cooling: Water  
Voltage: 400 / 500 V / 3Ph



### **jaw presses**

Heating surface (W x L): on request

Surface pressure: max. 140 N/cm<sup>2</sup>

Pressure medium: Pneumatic or water hydraulic Pressure cushion

Max. Heating temperature: 175 °C (higher values on request)

Heating medium: Tubular heating element

Heating capacity: approx. 6.5 - 10 kW / m<sup>2</sup>

Cooling: Water

Voltage: on request





## Container

Volume (W x L x H): on request / as required (max. 6 x 2.5 x 2.5 m<sup>3</sup>)

Fittings / brackets are manufactured / installed according to requirements



### **Longitudinal crack press Floecksmühle**

Heating surface (W x L): 350 x 12600 mm<sup>2</sup>

Surface pressure: 70 N/cm<sup>2</sup>

Pressure medium: water hydraulic pressure pads

Max. Heating temperature: 180 °C

Heating medium: Thermal oil

Heating capacity: 24 kW (switchable in three stages to 8 / 16 / 24 kW)

Cooling: Water

Voltage: 400V/3Ph

### **Stationary film sealing device**

Heating surface (W x L): 100 x 2000 mm<sup>2</sup>

Surface pressure: 70 N/cm<sup>2</sup>

Pressure medium: oil hydraulic cylinder

Max. Heating temperature: 180 °C

Heating medium: Tubular heating element

Heating capacity: 5 kW

Cooling: without

Voltage: 400V/3Ph

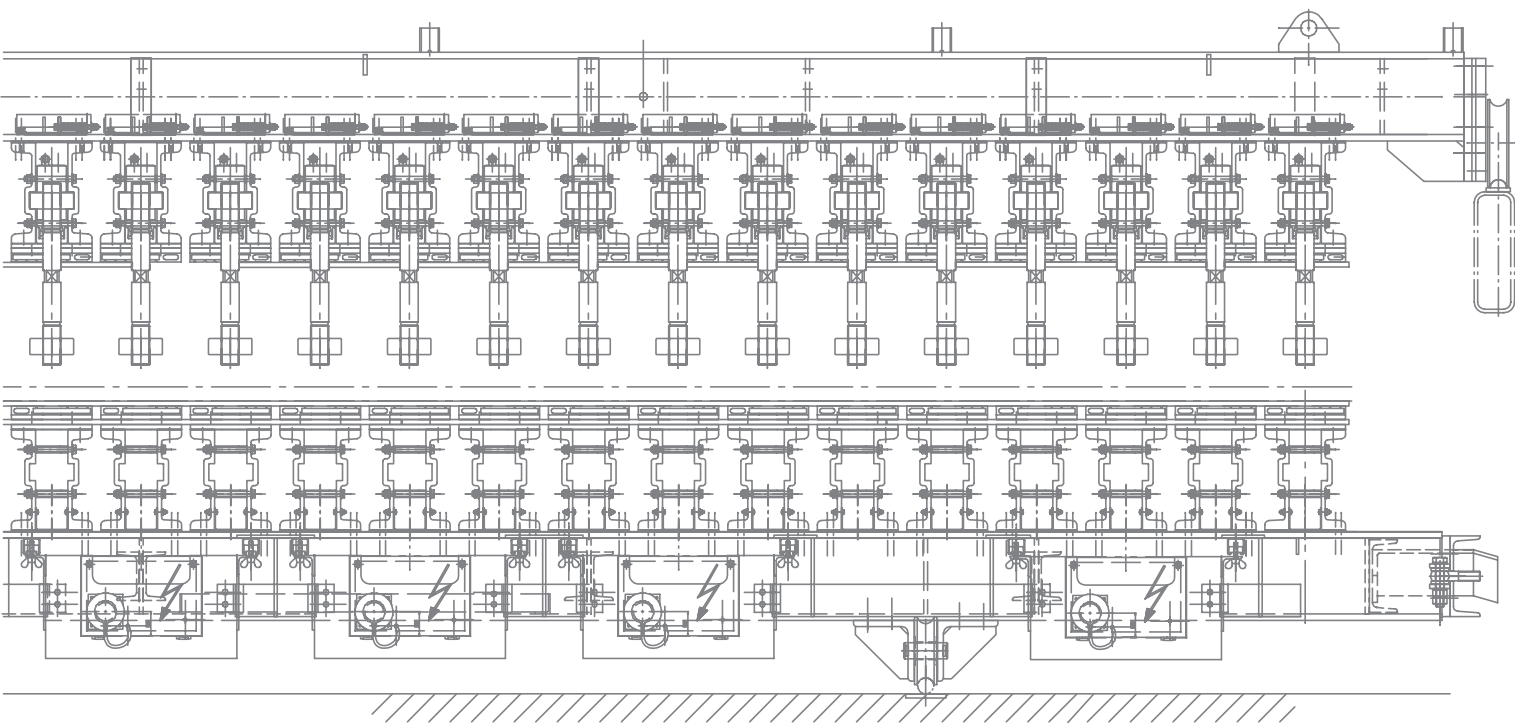

**WAGENER**

*Schwelm*

The technical information is based on latest state of technology. We reserve the right to make structural and design changes in the interest of progress. We ask for your understanding that no liability can be assumed for printing errors or mistakes. Reproduction or reprinting, in whole or in part, is not permitted without our express permission.

WSP\_EN  
This renders all previous instructions invalid.

**WAGENER Schwelm GmbH & Co.**  
Reisholzstr. 15  
40721 Hilden • Germany  
Phone: +49 2103 951 - 220  
Fax: +49 2103 951 - 229  
info@wagener-schwelm.de  
www.wagener-schwelm.de

