

MEDIUM TAKE-UP FRAME (SDTU)

TECHNICAL INFORMATION



Maintaining proper tension on the belt is crucial to prevent inefficiencies caused by belt slippage at the drive pulley and reduce belt sag, which can affect the product life of the belt and components. **ASGCO®'s Medium Take-Up Frame (SDTU)** can provide tension to the belt throughout the conveyor system, extending the life of the belt, reducing maintenance costs, and increasing yield.



Available with **Dodge®** and/or **Timken®** bearings upon request.

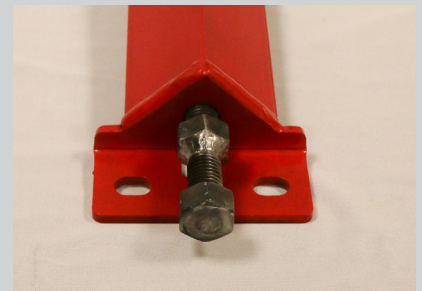
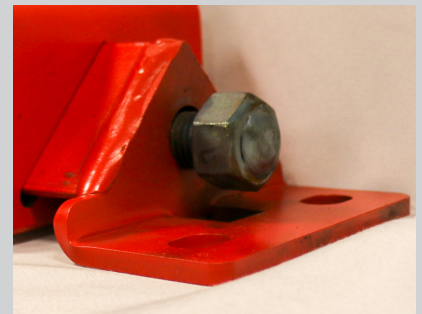
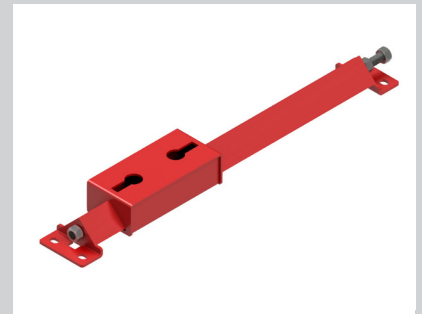

FEATURES AND BENEFITS

- Designed for lightweight to medium duty applications
- Solid one-piece bearing mount; pre-slotted for 2-bolt pillow block bearings
- Top-mounted
- Narrow frame for light installations

TAKE-UP STYLE					
	Bearing Style			Mounting Position	
	Pillow Block	Wide Slot	Top Angle	Top	Side
SDTU (Light Duty)	X			X	

BEARING BORE BASED ON PULLEY SHAFT SIZE										
	1"	2"	3"	4"	5"	6"	7"	8"	9"	
SDTU (Light Duty)	1/2" - 3-7/16"			↔						

TRAVEL LENGTH BASED ON CONVEYOR LENGTH											
Length of Conveyor	10'	20'	25'	50'	75'	100'	125'	150'	175'	200'	225"
Take-Up Travel Length (- 3% Stretch)	4"	7"	9"	18"	27"	36"	45"	54"	63"	72"	81"

COMMON COMPATIBLE 2-BOLT PILLOW BLOCK BEARINGS		
ASGCO Part Number	SC	SCM
SDTU10	≤ 1	-
SDTU20	1 7/16	1 7/16
SDTU30	1 15/16	1 11/16
SDTU40	2 3/16 - 2 7/16	1 15/16 - 2 3/16
SDTU45	2 11/16	2 7/16
SDTU50	2 15/16	2 15/16 - 3 7/16

EQUIVALENT OEM PART NUMBERS			
Martin	Dodge	Precision	Superior
MLD10	LD-10	PMD100	TULD-100
MLD20	LD-20	PMD108	TULD-200
MLD30	LD-30	PMD200	TULD-300
MLD40	LD-40	PMD208	TULD-400
MLD45	LD-45	PMD300	TULD-450
MLD50	LD-50	PMD308	TULD-500

Need Solutions... to improve efficiency, safety and productivity? **ask... ASGCO®**
www.asgco.com | 800.344.4000

@2024 ASGCO® "Complete Conveyor Solutions"



MEDIUM TAKE-UP FRAME (SDTU)

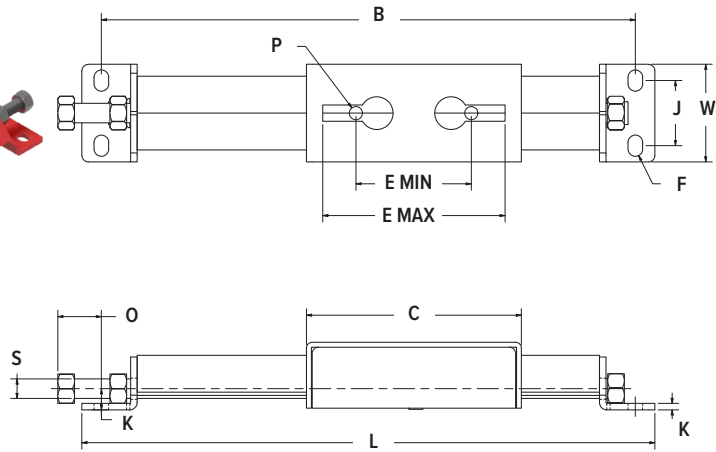
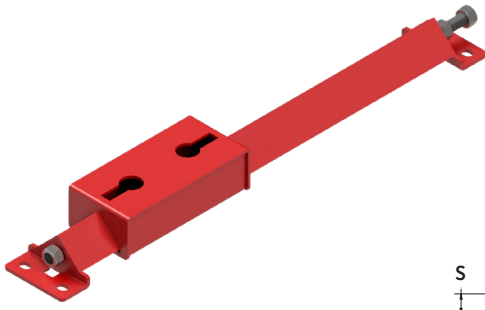

MEDIUM DUTY TAKE-UP FRAME (SDTU)

Part Number	Travel Distance	Weight		B	C	D	E		F	H	J	K	L	N	O	P	S	W
		kg	lb				MIN	MAX										
ASG-SD10-6	6	4.54	10	18	6.625	3.5	2.875	4.375	0.375	2.75	2.5	0.25	19.5	1.125	1.625	0.375	0.75	3.5
ASG-SD10-9	9	4.99	11	20.5									22					
ASG-SD10-12	12	5.90	13	23.5									25					
ASG-SD10-18	18	6.80	15	29.5									31					
ASG-SD10-24	24	7.71	17	35.5									37					
ASG-SD10-30	30	8.62	19	41.5									43					
ASG-SD10-36	36	9.98	22	47.5									49					
ASG-SD10-42	42	10.88	24	53.5									55					
ASG-SD10-48	48	11.79	26	59.5	61													
ASG-SD20-6	6	4.54	10	18	8.25	3.75	4.44	6.25	0.5	2.56	2.5	0.25	19.5	1.125	1.625	0.5	0.75	3.5
ASG-SD20-9	9	4.99	11	20.5									22					
ASG-SD20-12	12	5.90	13	23.5									25					
ASG-SD20-18	18	7.26	16	32									33.5					
ASG-SD20-24	24	8.16	18	38									39.5					
ASG-SD20-30	30	9.07	20	44									45.5					
ASG-SD20-36	36	10.88	24	50									51.5					
ASG-SD20-42	42	11.34	25	56									57.5					
ASG-SD20-48	48	12.24	27	62	63.5													
ASG-SD30-12	12	7.71	17	26.75	9	34	5.75	7	0.5	2.69	2.5	0.25	28.25	1.125	1.625	0.625	0.75	3.5
ASG-SD30-18	18	8.62	19	32.75									34.25					
ASG-SD30-24	24	9.98	22	38.75									40.25					
ASG-SD30-30	30	10.88	24	44.75									46.25					
ASG-SD30-36	36	11.79	26	50.75									52.25					
ASG-SD30-42	42	13.15	29	56.75									58.25					
ASG-SD30-48	48	14.06	31	62.75									64.25					
ASG-SD40-12	12	9.98	22	26.75									10					
ASG-SD40-18	18	11.34	25	32.75	34.25													
ASG-SD40-24	24	12.70	28	38.75	40.25													
ASG-SD40-30	30	14.06	31	44.75	46.25													
ASG-SD40-36	36	15.42	34	50.75	52.25													
ASG-SD40-42	42	16.33	36	56.75	58.25													
ASG-SD40-48	48	17.69	39	62.75	64.25													
ASG-SD45-12	12	29.02	64	31.25	14.5	5.5	6	11.25	0.75	4.13	3	0.5		33.375	1.5	2.25	0.75	1
ASG-SD45-18	18	31.75	70	37.5									39.625					
ASG-SD45-24	24	34.47	76	43.5									45.625					
ASG-SD45-30	30	37.19	82	49.5									51.625					
ASG-SD45-36	36	39.46	87	55.5									57.625					
ASG-SD45-42	42	42.18	93	61.5									63.625					
ASG-SD45-48	48	44.90	99	67.5									69.625					
ASG-SD50-6	6	26.30	58	25.25									14.5	5.5				
ASG-SD50-12	12	29.02	64	31.25	33.375													
ASG-SD50-18	18	31.75	70	37.5	39.625													
ASG-SD50-24	24	34.47	76	43.5	45.625													
ASG-SD50-30	30	36.73	81	49.5	51.625													
ASG-SD50-36	36	39.46	87	55.5	57.625													
ASG-SD50-48	48	44.90	99	67.5	69.625													

*** All dimensions are in inches.

Need Solutions... to improve efficiency, safety and productivity? ask... ASGCO®

www.asgco.com | 800.344.4000

@2024 ASGCO® "Complete Conveyor Solutions"

