

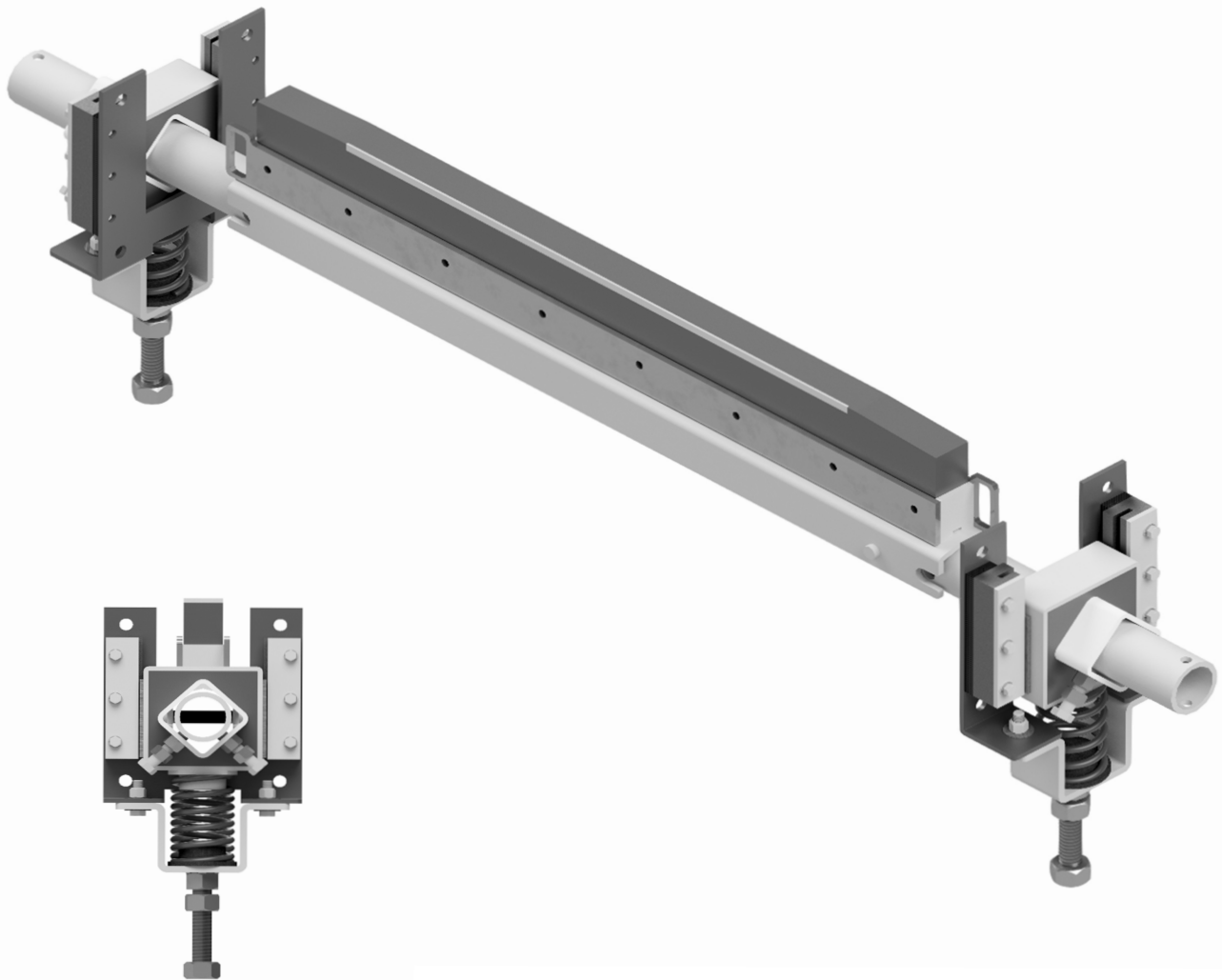

RAZOR-BACK® CSB HD

WITH SPRING-SHOC™ TENSIONER SYSTEM

INSTALLATION, OPERATION & MAINTENANCE INSTRUCTIONS



Check us out at
www.asgco.com



Customer Service
800-344-4000

24 Hour Emergency
Service and Parts
610-821-0210

ASGCO Mfg., Inc.
730 Bangor Rd.
Nazareth, PA 18064
610-821-0216
FAX 610-778-8991



**Important
Safety
Notice**

Always observe the basic rules of safety when working with any conveyor system. To avoid injury and equipment damage, be sure that all controls to the conveyor are locked out and the power source is disconnected at all times during installation and maintenance.

Overall View

Always observe the basic rules of safety when working with any conveyor system. To avoid injury and equipment damage, be sure that all controls to the conveyor are locked out and the power source is disconnected at all times during installation and maintenance.

**Components
Diagram**

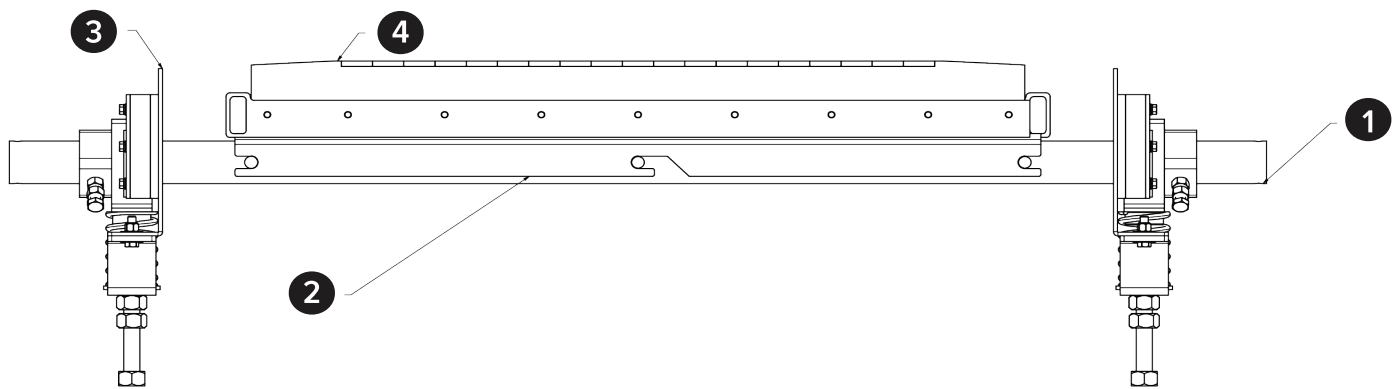
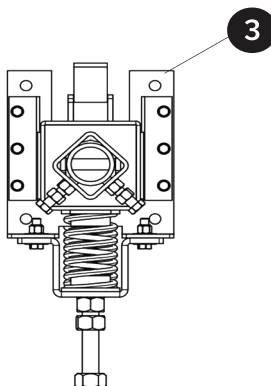

Figure 1. Spring-Shoc™ Tensioner Parts Diagram



- 1 - Mounting Tube
- 2 - Blade Holder Cartridge
- 3 - Spring-Shoc™ Tensioner
- 4a - CSB Flat Carbide Blade
- 4b - CSB Flat Urethane Blade *(Not shown)*
- 4c - CSB Curved Urethane Blade *(Not shown)*

Razor-Back Spring-Schoc™ Tensioner Components

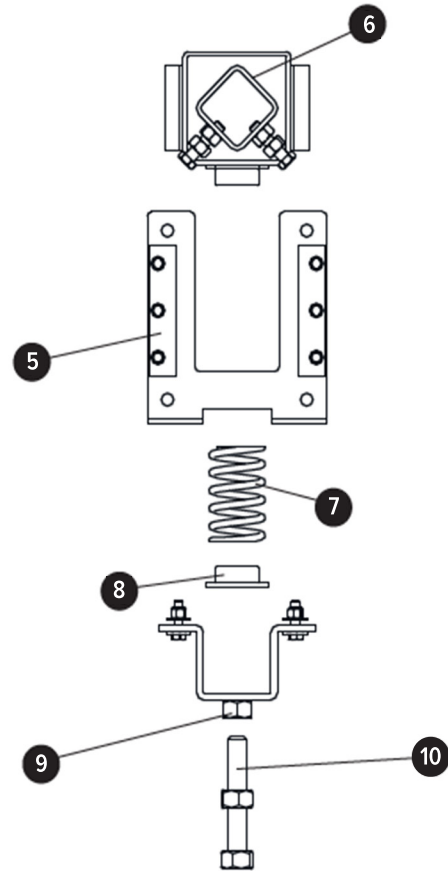

Figure 2. Spring-Schoc™ Tensioner Parts Diagram

Spring-Schoc™ Tensioner Parts List

	Qty.
⑤ - Mounting Bracket	(2)
⑥ - Slide Black w/Set Screws	(2)
⑦ - Compression Spring	(2)
⑧ - Half Hole Locator	(2)
⑨ - ACME Lock Down Nut	(2)
⑩ - ACME Adjustment Bolt	(2)

Determine Cleaner Mounting Location

The Razor-Back CSB HD is a secondary belt cleaner and as such should be located on the return side of the belt after the belt leaves contact with the head pulley as shown below. Preferably it should be located within the confines of the head or dribble chute. See Figure 3.

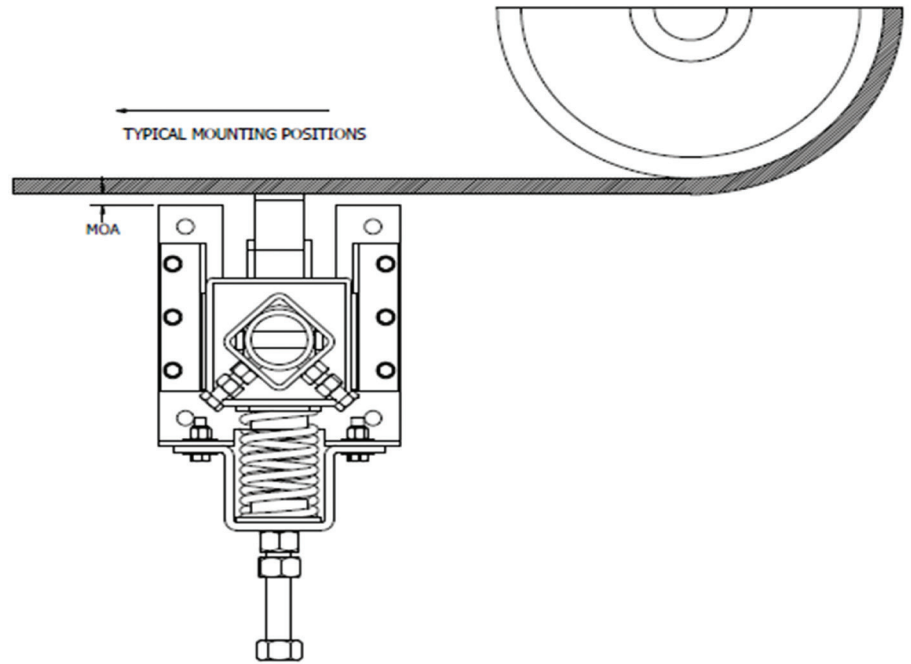

Figure 3. Typical Cleaner Mounting Locations

- The Tips of the Razor-Back CSB HD should be horizontally located as close as possible to Belt Tangent Point (the point where the belt leaves contact with the head pulley). This will ensure the belt is as flat as possible, to provide the most effective cleaning.
- Do not place the Tips of the Razor-Back CSB HD against the belt where it is still in contact with the pulley, as this can cause damage to the belt surface.
- Make sure the Mounting Brackets are mounted perpendicular to the belt.
- The recommended minimum clearance between the Tips of the Razor-Back CSB HD and a snub pulley or dribble chute is 5 ½ inches (140 mm).

Locate Mounting Bracket

The Mounting Bracket should be attached to the chute wall or conveyor structure using the four mounting holes and ½-13 UNC x 2 ½ inch hex head bolts. See Figure 4 for mounting hole dimensions.

NOTE: The Mounting Brackets can also be welded in place.

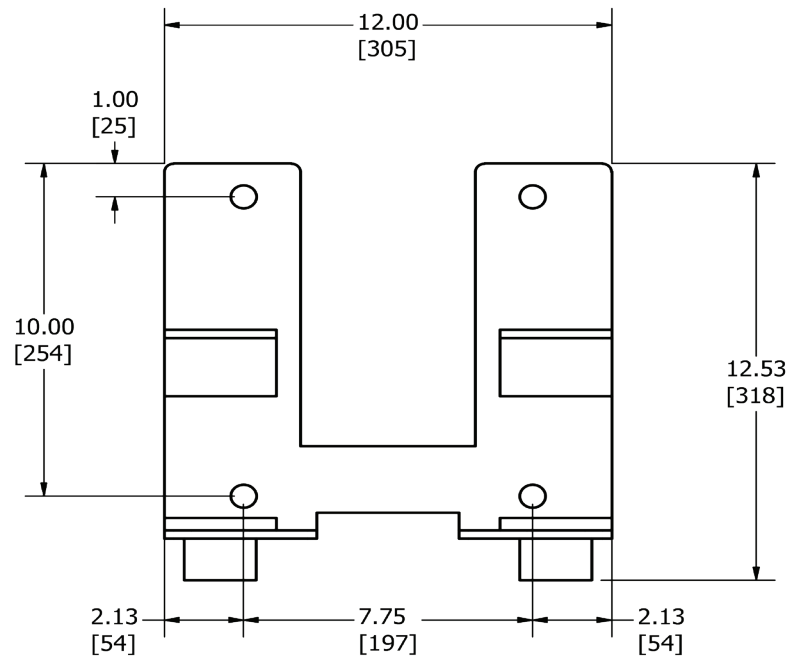

Figure 4. Mounting Bracket Hole Dimensions

- To determine the desired vertical location of the Mounting Brackets, locate the Mounting Bracket so that the bracket mounting holes are located below the bottom edge of the belt, at the dimensions shown in Figure 4.
- If the Razor-Back CSB HD is to be installed on a conveyor with an enclosed chute, it may require that slots and holes be cut to mount the cleaner. If required, mark and cut slots of the chute side wall to allow the Mounting Tube to pass. The required slot size/location and hole size/location are shown in Figure 4.
- Attach Mounting Brackets to conveyor structure or chute sidewall, with provided Hardware or Welding.

Install Razor-Back CSB HD

- With the Mounting Brackets attached, now assemble the Spring-Shoc Tensioners as shown in Figure 2.
- Slide the Mounting Tube through the Slide Blocks of the assembled Spring-Shoc Tensioners.
- Install Blade Holder with Hitch Pin. Then center the Blade Tips on the belt by sliding the Mounting Tube in the Slide Blocks.
- With the Blade Tips centered on the belt, firmly tighten the set screws (to approximately 75 ft-lbs) on the Slide Blocks to affix the translation of the Mounting Tube.

Install Razor-Back CSB HD

- Raise the Slide Blocks by evenly turning the Adjustment Bolts until the Blade Tips just contact the bottom of belt surface. Check that the Blade Tips are evenly contacting the belt along the entire length of the Blade Tips.
- Once uniform blade/belt contact has been achieved, evenly raise the Slide Blocks causing the spring to load. Continue to tighten until sufficient upward force (blade pressure) has been achieved; see Table 1. Spring Height (H) is the suggested tension starting point. See Figure 5.

Table 1. Spring-Shoc Tensioner, Tension Chart

Belt Width (in)	Belt Width (mm)	Spring Compression (in)	Spring Compression (mm)	Spring Height (H) (in)	Spring Height (H) (mm)
42	1050	5/8	15.8	4 3/8	111.1
48	1200	3/4	19.0	4 1/4	108.0
54	1350	13/16	20.6	4 3/16	106.4
60	1500	7/8	22.2	4 1/8	104.8
66	1650	1	25.4	4	101.6
72	1800	11/16	26.9	3 15/16	100.0
84	2100	1 1/4	31.7	3 3/4	95.3
96	2400	1.375	34.9	3 5/8	92.1

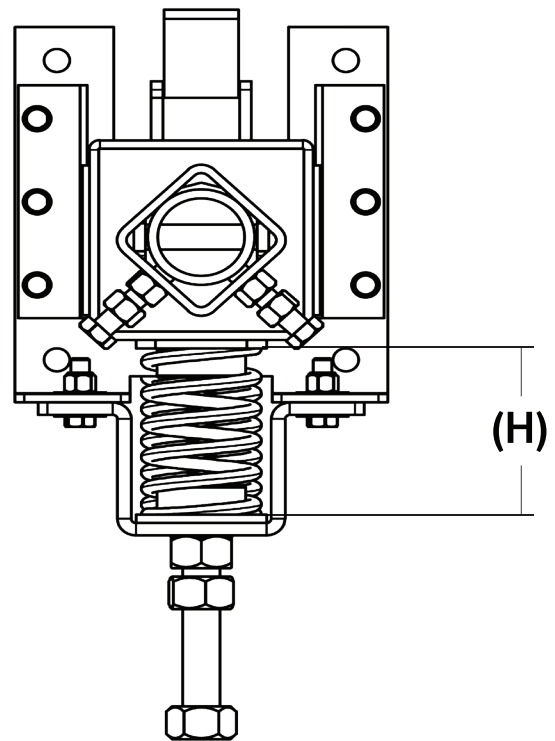

Figure 5. Spring Height (H)

- It may be possible that there is enough play in the belt that there can be enough downward force via belt weight so that compressing the spring may not be necessary.
- Firmly tighten the Lock Down Nut on the Adjustment Bolt once appropriate tension is applied.
- Test run the conveyor. If chattering or vibration of the Blade Tips occurs, try increasing the spring compression or rotating the Mounting Tube 5 degrees in the direction of belt travel.

OPERATION & MAINTENANCE

AFTER ONE DAY OF OPERATION:

1. Inspect the cleaner for proper belt cleaning and operation.

Weekly:

1. Frequent inspection is the key to proper belt cleaning and easy scraper servicing. Weekly inspections are recommended, but actual service frequency may vary widely depending on various plant operating conditions.
2. Wash the entire cleaner regularly to prevent excessive build-up. If material tends to accumulate on the Scraper Assembly, possible scraper relocation may be in order.
3. Carefully inspect the wear tips of the cleaner blades. Make sure the blades are not chipped or worn out.
4. Inspect the belt surfaces and edges for cracks, splits, tears, holes, or any other worn or damaged condition occurring on the surfaces or edges of the belt itself. If the belt is worn or damaged, make necessary repairs.

REPLACEMENT AND RE-TENSIONING OF CLEANING BLADES

1. Lower the Mounting Tube by loosening the Adjustment Bolt on both sides of the cleaner. This will disengage the cleaner Blade Tips from the belt.
2. To remove the Cartridge Blade Holder from the Mounting Tube, remove the Hitch Pin. It may be necessary to loosen the Set Screws from both Slide Blocks to rotate the Mounting Tube.
3. Slide the Blade Holder, with Blade Tips and Cushions attached, out through the Mounting Bracket.
4. Loosen and remove the nuts and washers holding the Blade Tips onto the Razor-Back Cushion.
5. Remove the worn Blade Tips and discard.
6. Position new Blade Tips on the Razor-Back Cushions and reinstall the nuts and washers to hold the Blade Tips on the Razor-Back Cushions, making sure the Blade Tips are flush along the leading edge.
7. Reinstall the Blade Holder, making sure to center the Blade Tip on the conveyor belt. Tighten the Set Screws and engage the Blade Tips according to the instructions above.

Information

KEY	DESCRIPTION	PART NUMBER
1	Mounting Tube	ASG-RBMT - (BW) [BW]=Belt Width
2	Blade Holder	ASG-CSBHD-BH-(BW)
3	Spring-Shoc Tensioner	ASG-MDX-RB-ST
4a	CSB Flat Carbide Blade	ASG-URE-CSB-(BW)F-C
4b	CSB Flat Urethane Blade	ASG-URE-CSB-(BW)F-U
4c	CSB Curved Urethane Blade	ASG-URE-CSB-(BW)C-U
5	Hitch Pin	ASG-MDX-RB-HP
6	Mounting Bracket	ASG-STMDX-MB
7	Slide Block	ASG-STMDX-SB
8	Set Screws	AS-SCREW-C08x016
9	Compression Spring	ASG-STMDX-SPRING
10	Spring Bushing	ASG-STMDX-PUSB
11	ACME Lock Down Nut	ASG-RST-3/4-6-NUT
12	ACME Adjustment Bolt	ASG-RST-3/4-6x7-1/2

Call your ASGCO Distributor for any questions or replacement parts

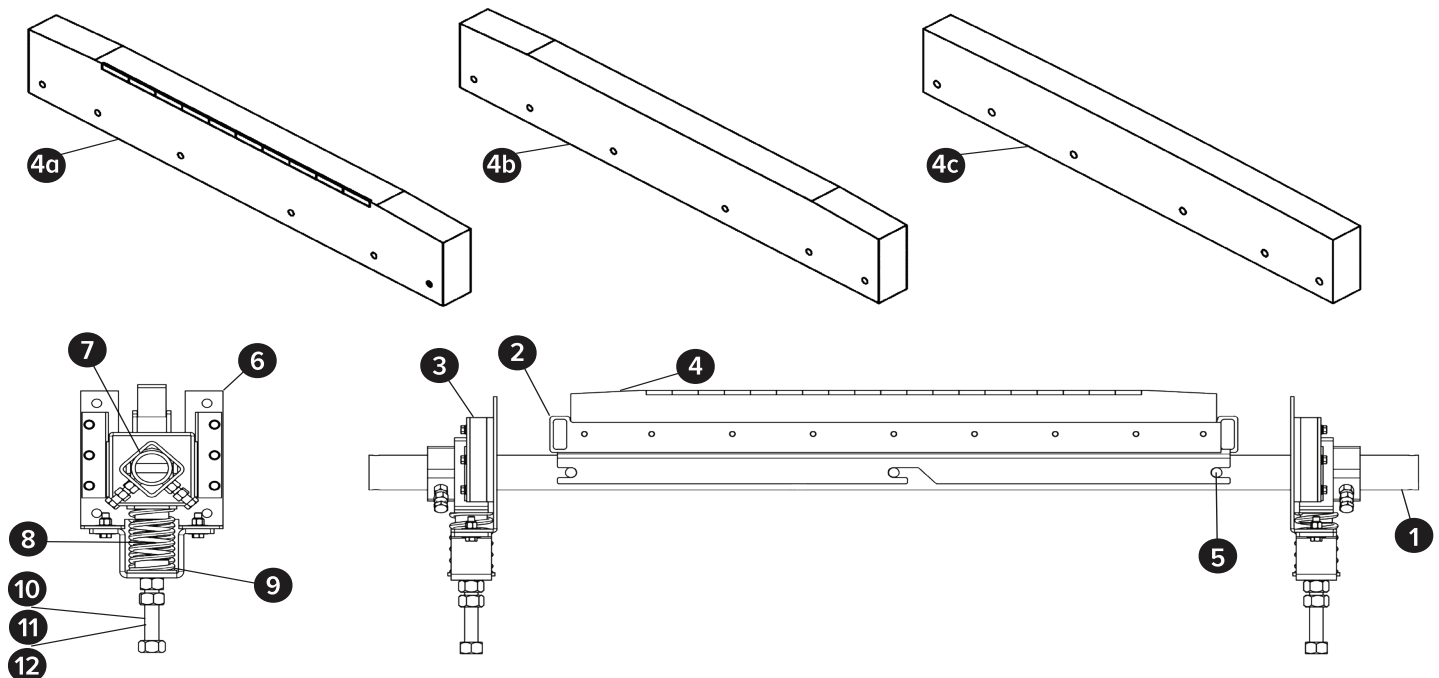

TROUBLESHOOTING

PROBLEM	SOLUTION
Excess vibration of the scraper.	Make certain all bolts are tight. If belt is non-reversing, rotate the blade about 5 degrees in the direction of the belt movement.
Excess carryback.	Check for proper Scraper tension. Put additional tension on cleaner.
Excess belt movement, cupping	Install a hold down roller to stabilize the belt surface.
Unable to tension scraper properly belt moves away from blades.	Install a hold down roller to reduce sag of the belt when tensioning.
Frozen material on scraper.	Place heaters near scraper to melt frozen material. (Use caution not to burn belt or cleaner)